

EC08 DYNAPAC

580-61030-00

WALBRO

WI 57A

FIG. 5 CARBURETOR and AIR CLEANER

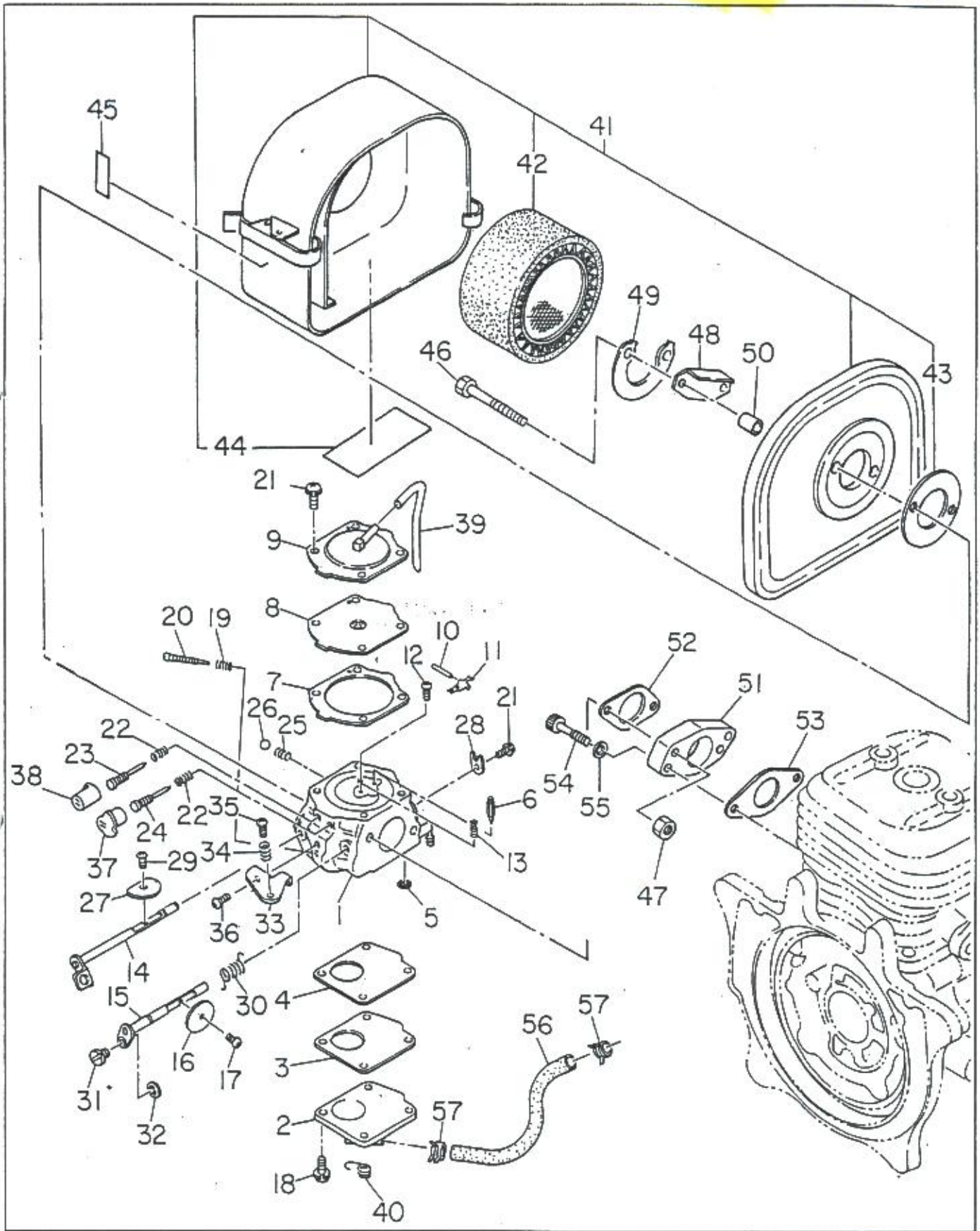

FIG. 5 CARBURETOR and AIR CLEANER

Interchangeability

Ref. No.	Parts Number	Description	Q'ty	Execution
* 1	580 - 61090 - 00	CARBURETOR Includes itmes 2 thru 40	1	
2	580 - 61020 - 10	COVER ASS'Y	1	
3	580 - 60841 - 50	GASKET	1	
4	580 - 60841 - 60	DIAPHRAGM	1	
5	501 - 60040 - 10	SCREEN	1	
6	501 - 60050 - 30	VALVE (inlet needle)	1	
7	580 - 60842 - 10	GASKET	1	
8	580 - 60842 - 20	DIAPHRAGM ASS'Y	1	
9	580 - 61090 - 10	COVER ASS'Y	1	
10	523 - 60270 - 10	PIN	1	
11	580 - 60841 - 40	LEVER (metering)	1	
12	501 - 60041 - 10	SCREW	1	
13	580 - 60840 - 30	SPRING	1	
14	580 - 61020 - 20	SHAFT ASS'Y (choke)	1	
15	580 - 61020 - 30	SHAFT ASS'Y (throttle)	1	
16	580 - 60840 - 60	VALVE (throttle)	1	
17	580 - 60842 - 40	SCREW	1	
18	580 - 60842 - 50	SCREW ASS'Y	4	
19	510 - 60452 - 20	SPRING	1	
20	580 - 60843 - 10	SCREW	1	
21	501 - 60041 - 60	SCREW ASS'Y	5	
22	580 - 60841 - 10	SPRING	2	
23	580 - 61021 - 60	NEEDL (high speed)	1	
24	580 - 61022 - 10	NEEDLE (idle)	1	
25	580 - 60843 - 20	SPRING	1	
26	580 - 60843 - 30	BALL	1	
27	580 - 60843 - 40	VALVE (choke)	1	
28	510 - 60450 - 40	CLIP	1	
29	510 - 60451 - 40	SCREW	1	
30	580 - 61021 - 20	SPRING	1	
31	524 - 60012 - 10	SWIVEL	1	
32	580 - 61020 - 40	RING	1	
33	580 - 61022 - 20	BRACKET	1	
34	580 - 61021 - 30	SPRING	1	
35	580 - 61021 - 40	SCREW	1	
36	580 - 61021 - 50	SCREW	1	
37	580 - 61020 - 50	CAP (limiter)	1	
38	580 - 61020 - 60	CAP (limiter)	1	
39	580 - 61090 - 20	HOSE	1	
40	580 - 61090 - 30	SUPPORT. HOSE	1	
* 41	106 - 32727 - 10	CLEANER, AIR Includes items 42 thru 44	1	
42	106 - 32704 - 07	ELEMENT SET	1	
43	106 - 32723 - 08	PACKING	1	
44	106 - 32738 - 08	LABEL	1	