



Robin Engine

Model EC08

for BOMAG

PARTS CATALOG

Spec.No. EC080DD0841

 **富士重工業株式会社**
FUJI HEAVY INDUSTRIES LTD.

FIG. 100

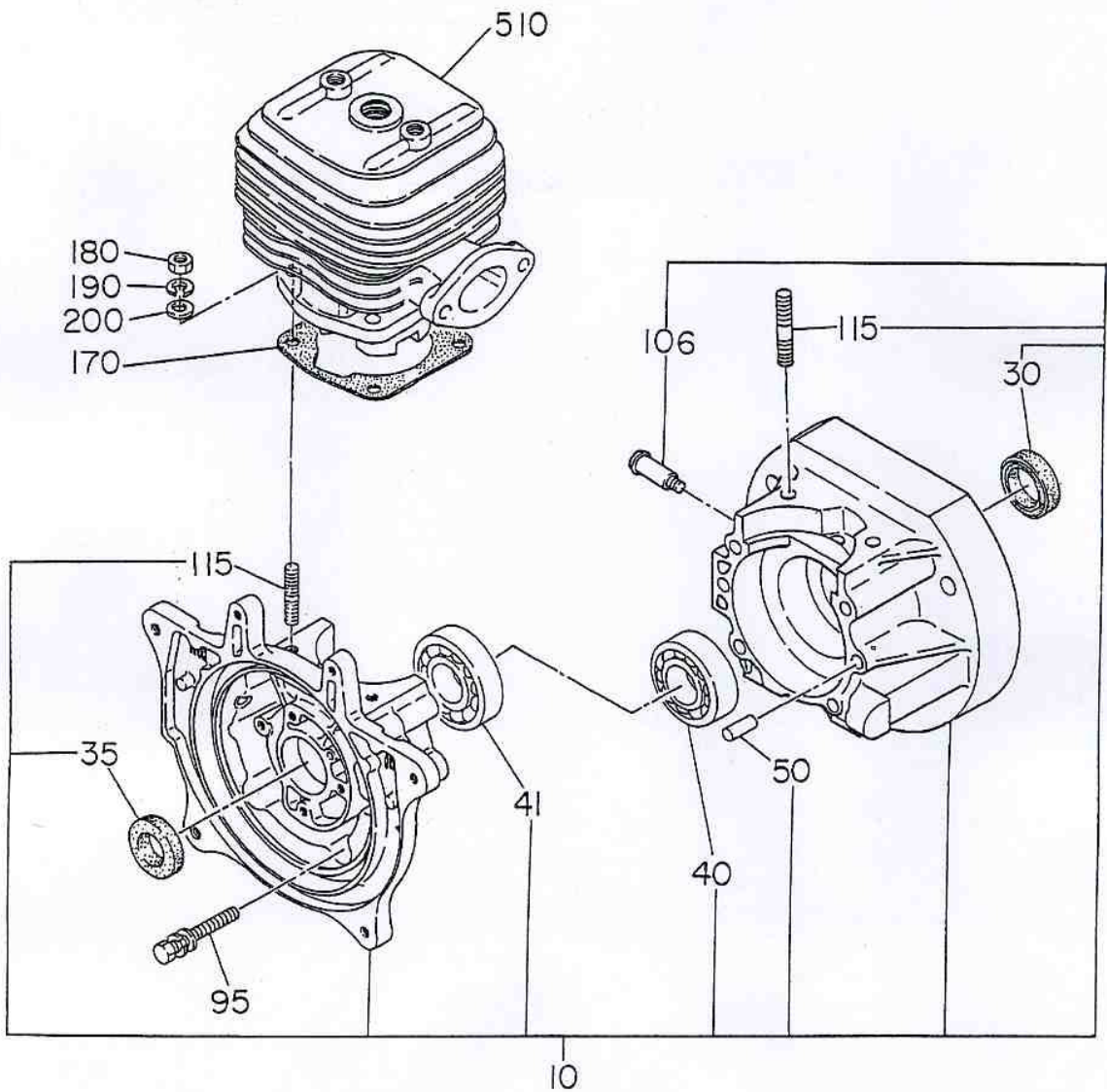

FIG. 200

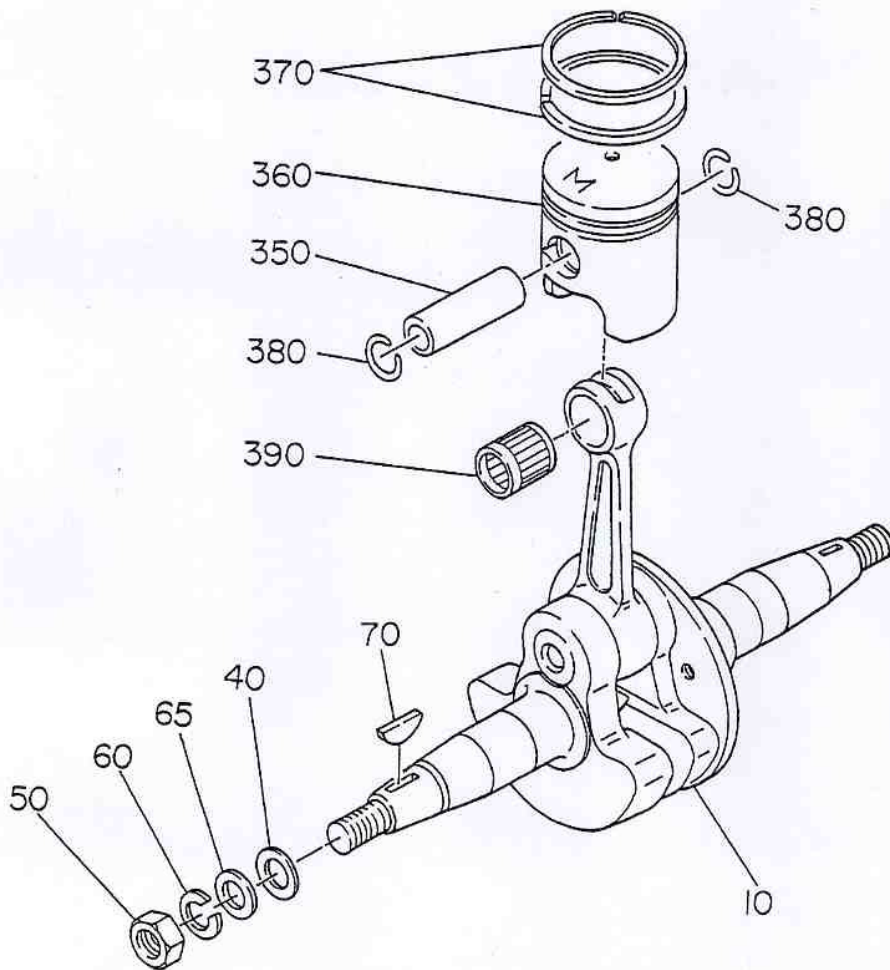

FIG. 300

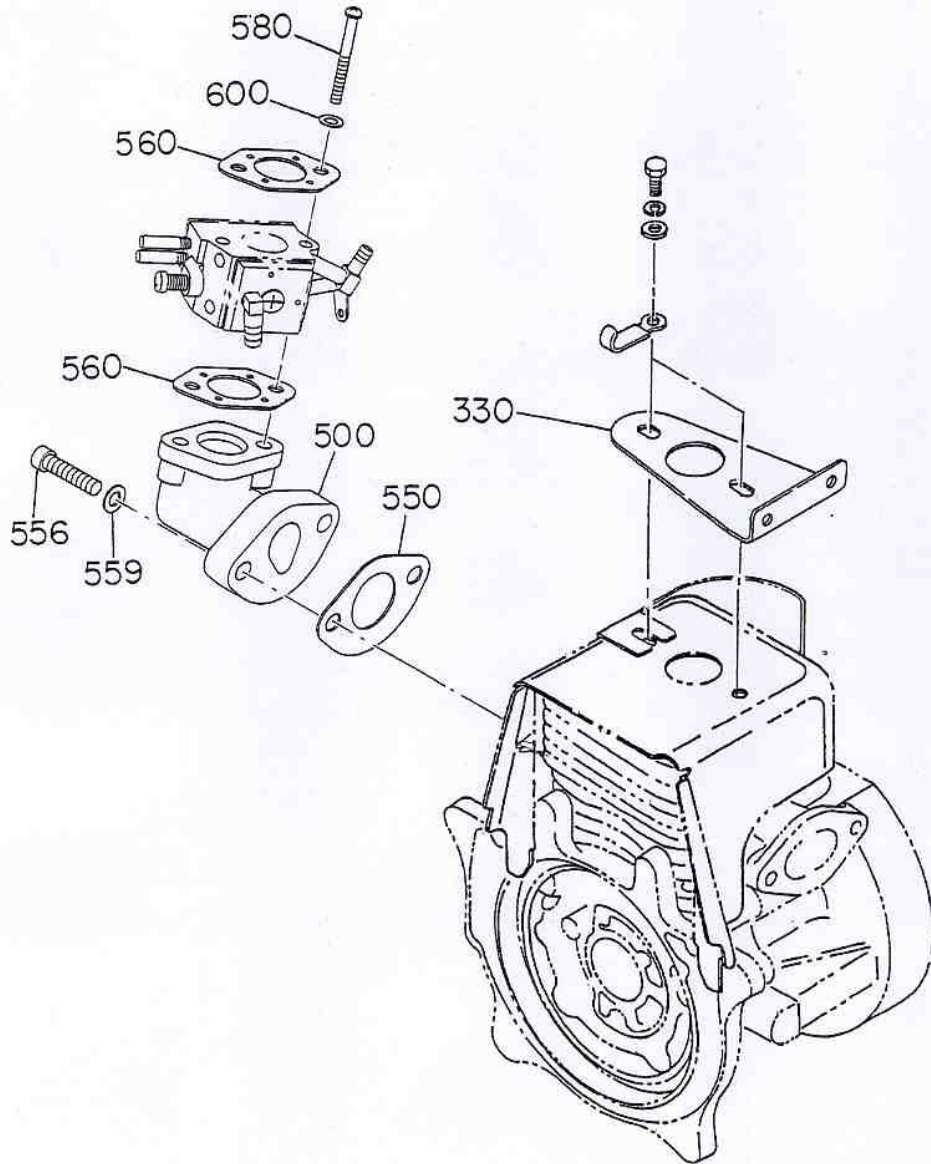
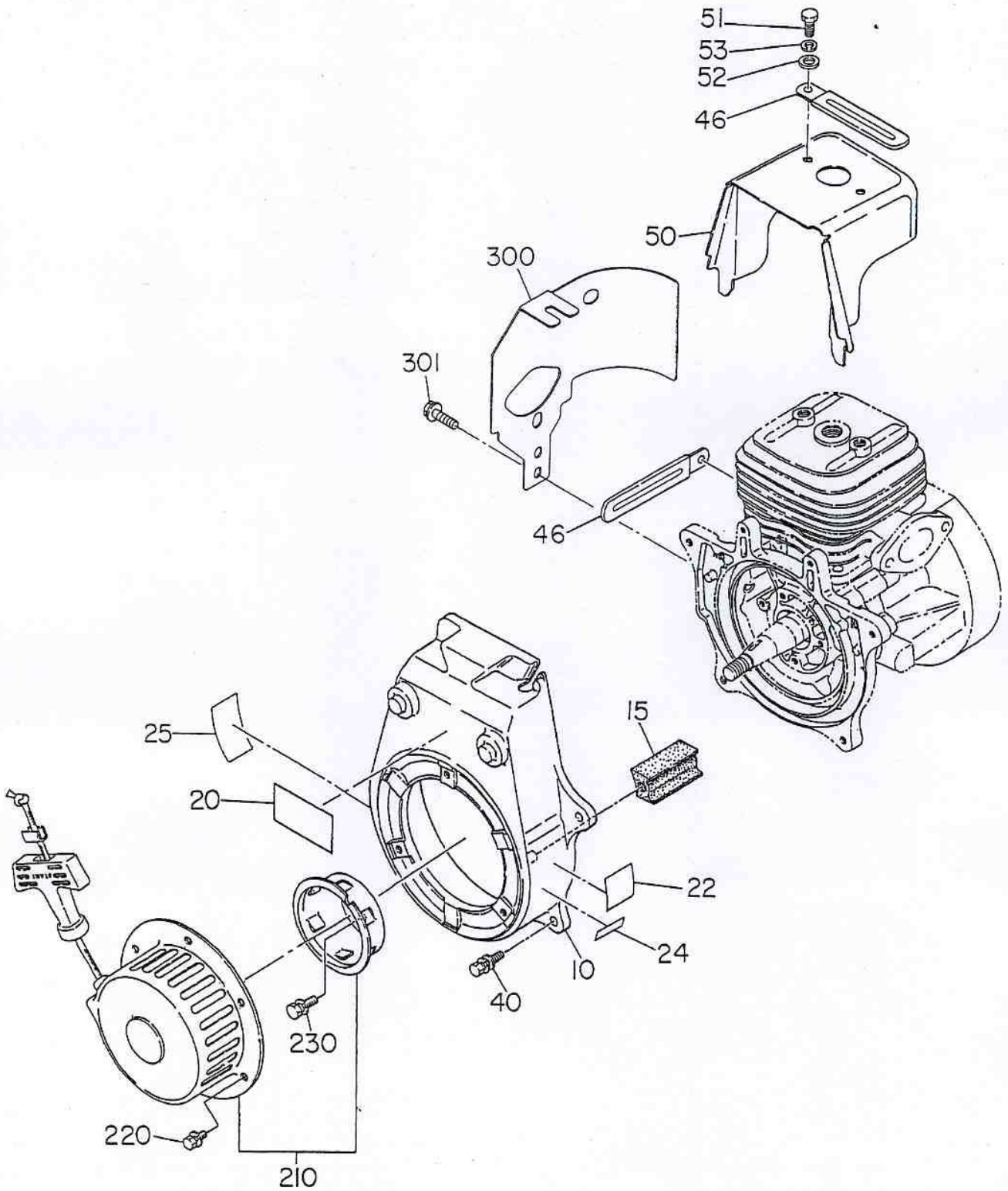

FIG. 500



REFER TO FIG. 5100

FIG. 600

REFER TO FIG. 6100

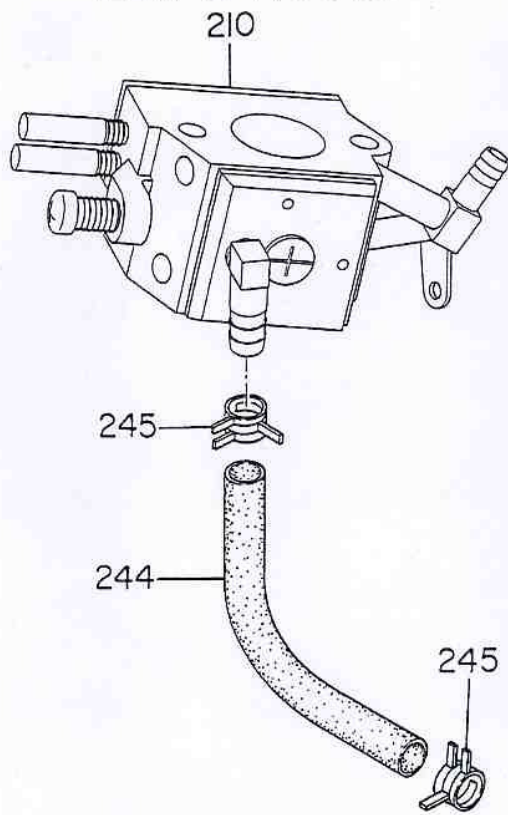

FIG. 900

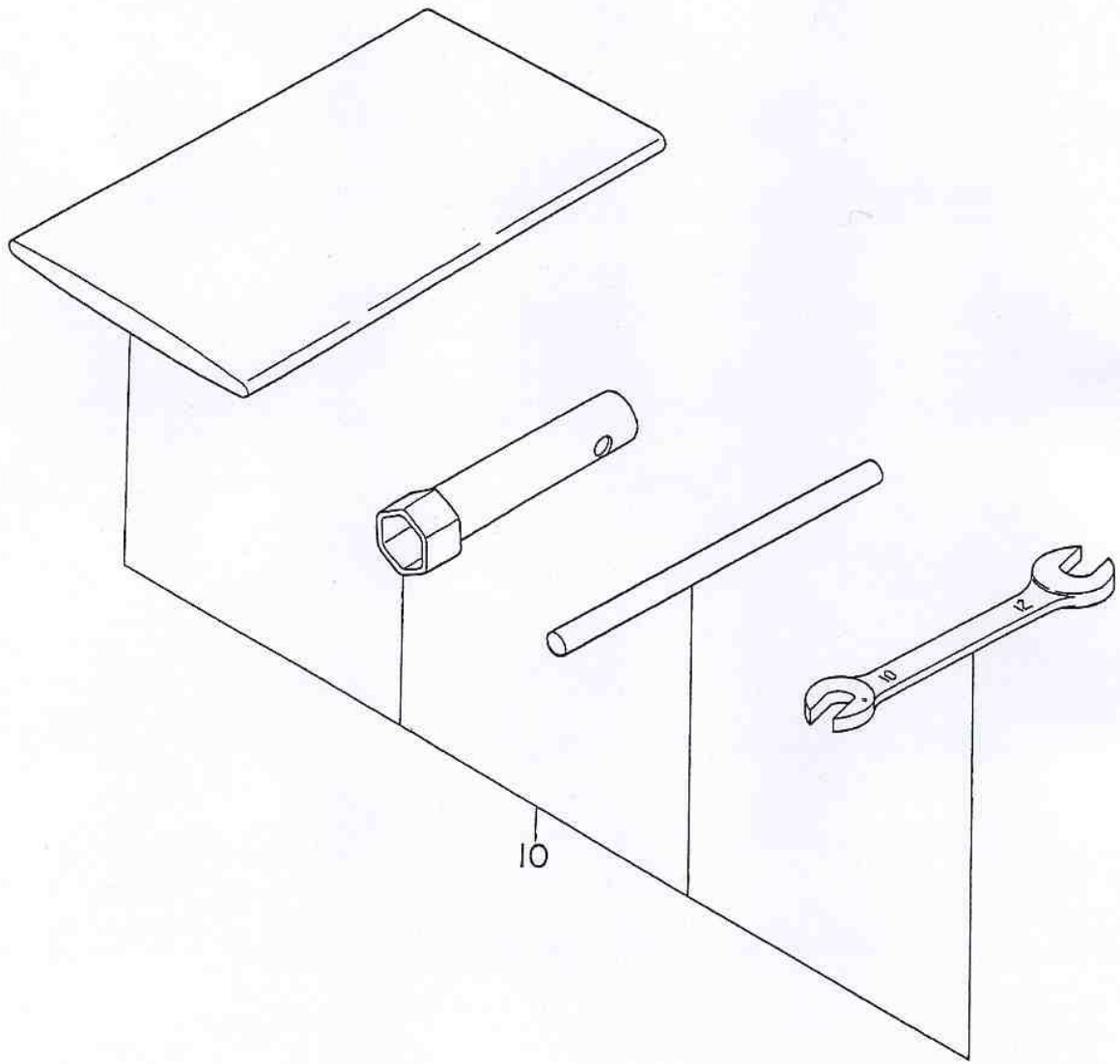

FIG. 5100

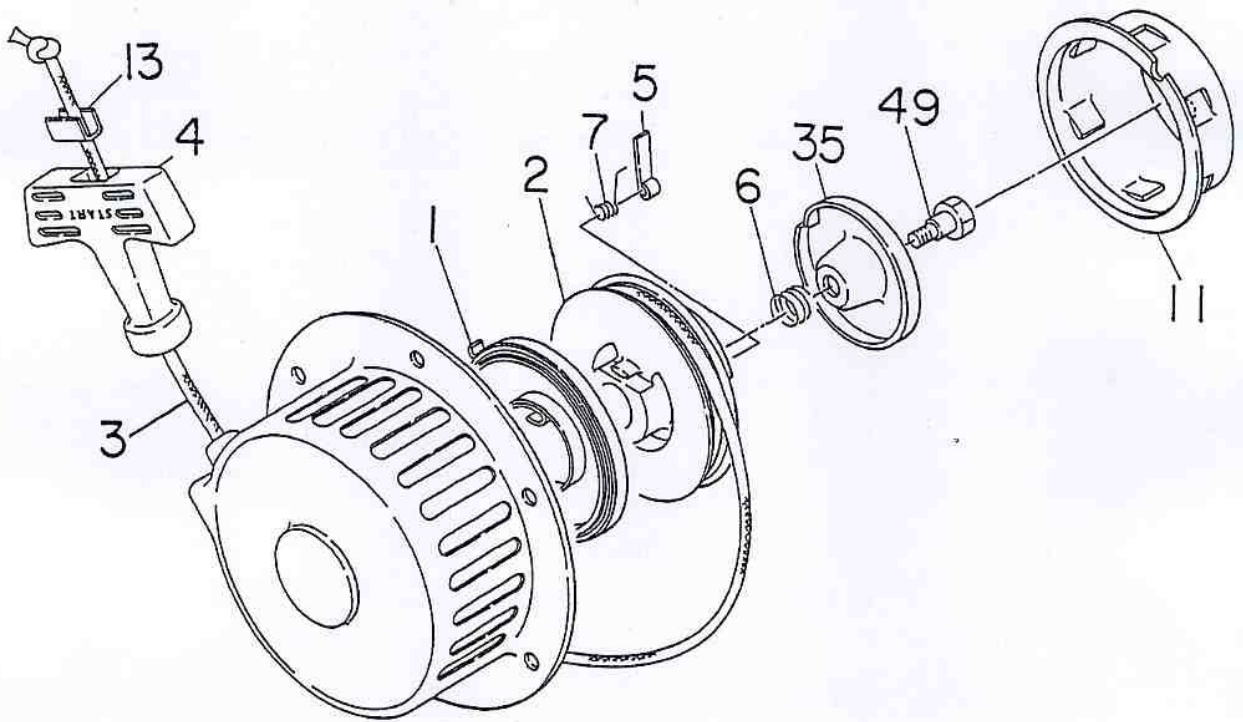
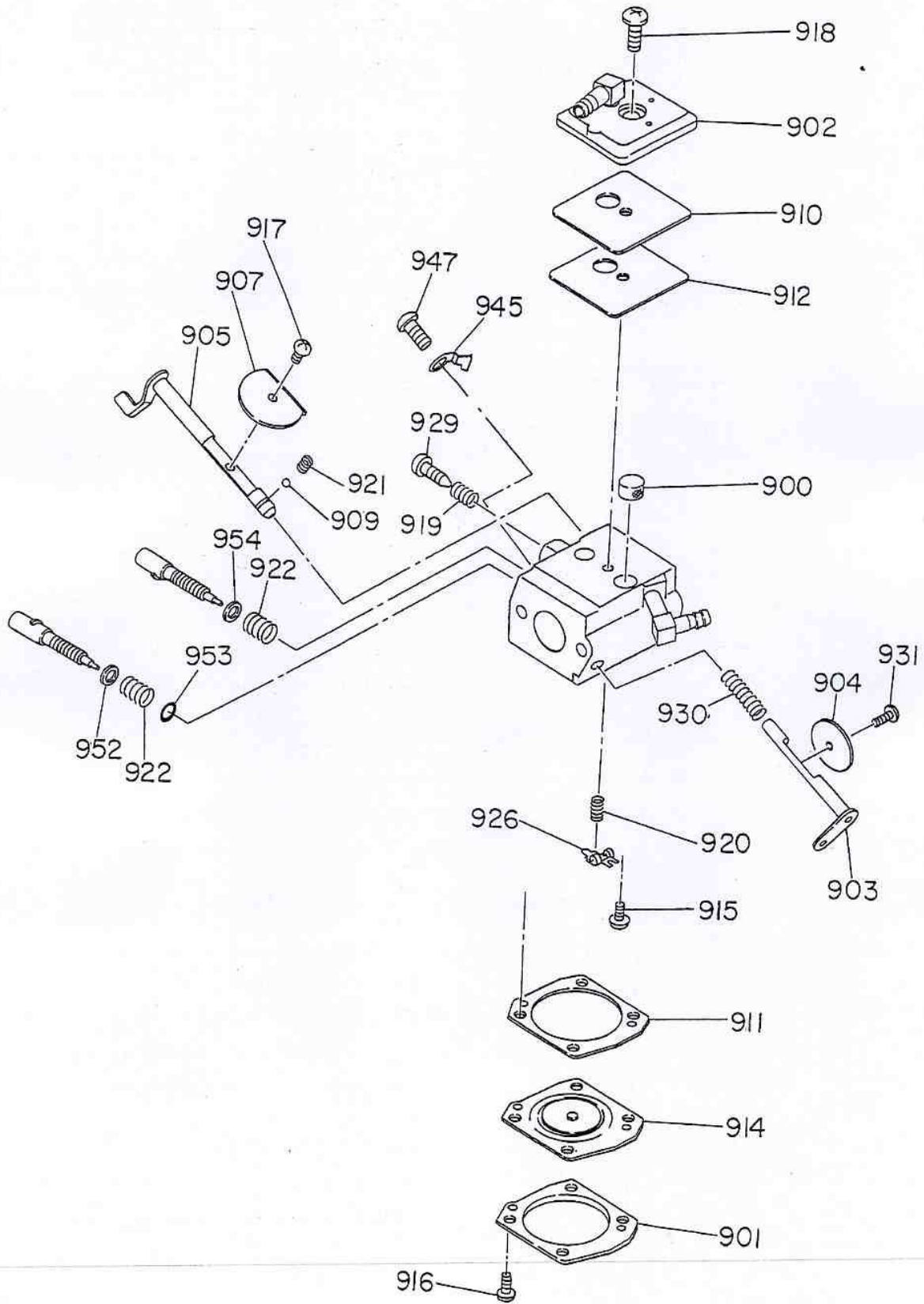

FIG. 6100

HDA 176



61 CARBURETOR AY

REF.	PART NUMBER	PART NAME	QTY	REMARKS	CODE NO. FROM-TO	INTERCHANGEABLE PART NUMBER	UNIT PRICE	FIG.
900	501-60040-10	SCREEN	1		-			6100
901	580-61220-60	COVER-METERING DIAPH	1		-			6100
902	580-61220-10	COVER AY-PUMP	1		-			6100
903	580-61221-50	SHAFT AY-THROTTLE	1		-			6100
904	580-61222-60	VALVE-THROTTLE	1		-			6100
905	580-61222-30	SHAFT AY-CHOKE	1		-			6100
907	580-61222-40	VALVE-CHOKE	1		-			6100
909	580-61222-20	BALL	1		-			6100
X 910	580-61220-30	GASKET-PUMP	1		-			6100
X 911	580-61221-20	GASKET-METERING DIA.	1		-			6100
X 912	580-61220-40	DIAPHRAGM-PUMP	1		-			6100
X 914	580-61221-10	DIAPHRAGM AY-METERIN	1		-			6100
915	501-60041-10	SCREW	1		-			6100
916	501-60041-60	SCREW AY	4		-			6100
917	580-61222-50	SCREW-VALVE	1		-			6100
918	580-61220-20	SCREW-PUMP COVER	1		-			6100
919	541-60361-20	SPRING-IDLE ADJ.	1		-			6100
920	580-61220-50	SPRING-METERING LEVE	1		-			6100
921	580-61222-10	SPRING-CHOKE FRICTIO	1		-			6100
922	580-60801-10	SPRING	2		-			6100
926	580-61221-30	LEVER-METERING	1		-			6100
929	541-60361-30	SCREW-IDLE ADJ.	1		-			6100
930	580-61221-60	SPRING-THROTTLE RET.	1		-			6100
931	580-60842-40	SCREW-VALVE	1		-			6100
945	580-61221-40	STOP-THROTTLE	1		-			6100
947	510-60451-40	SCREW-SHUTTER	1		-			6100
952	521-60060-40	WASHER	1		-			6100
953	521-60060-50	O RING	1		-			6100
954	510-60381-20	WASHER	1		-			6100
	531-60051-50	VALVE NEEDLE	1					