



**Robin Engine**

Model EC08

for DYNAPAC

# PARTS CATALOG

Spec.No. EC08D\*\*0392

 **富士重工業株式会社**  
**FUJI HEAVY INDUSTRIES LTD.**

FIG. 1 CRANKCASE and CYLINDER HEAD

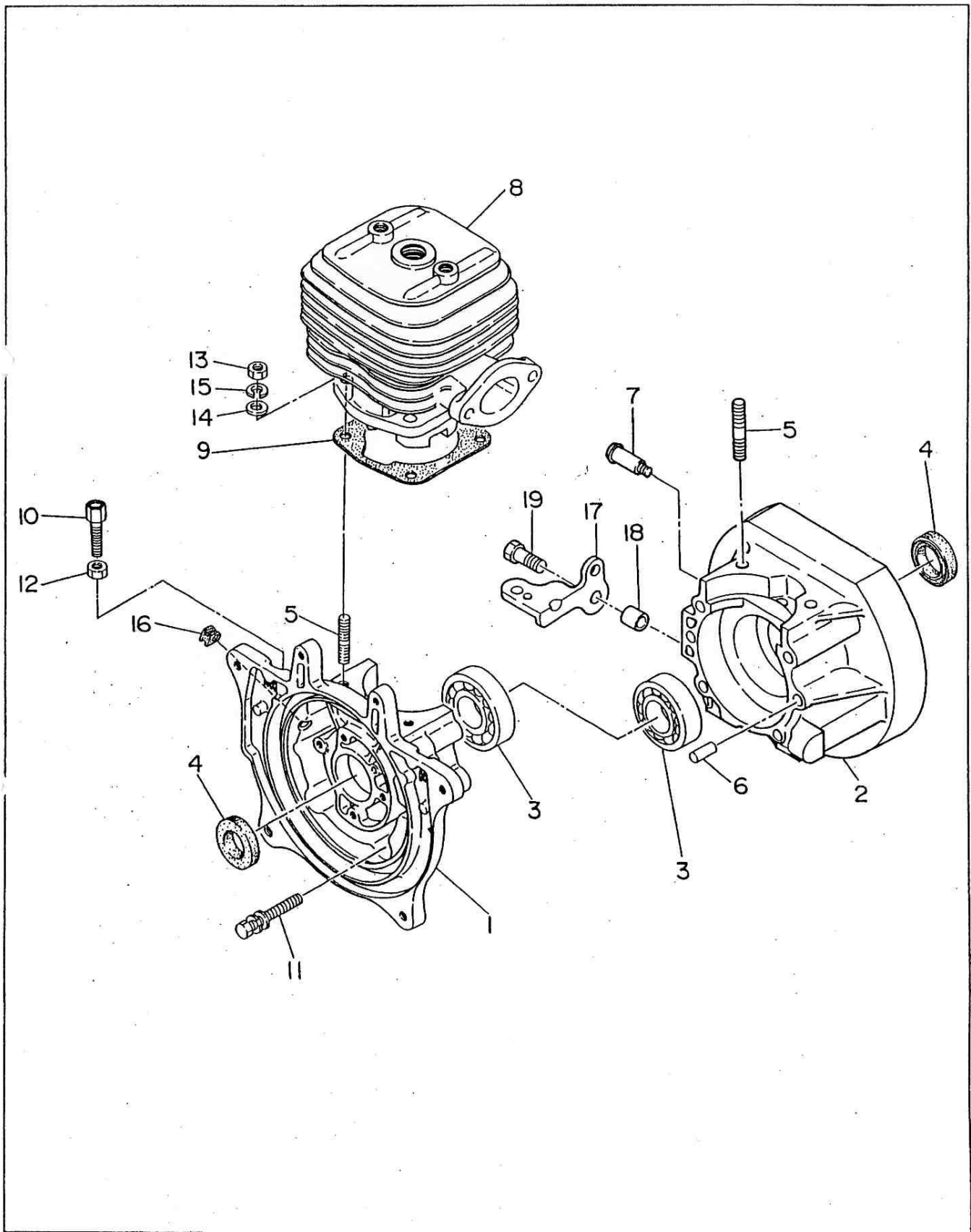



FIG. 2 CRANKSHAFT and PISTON

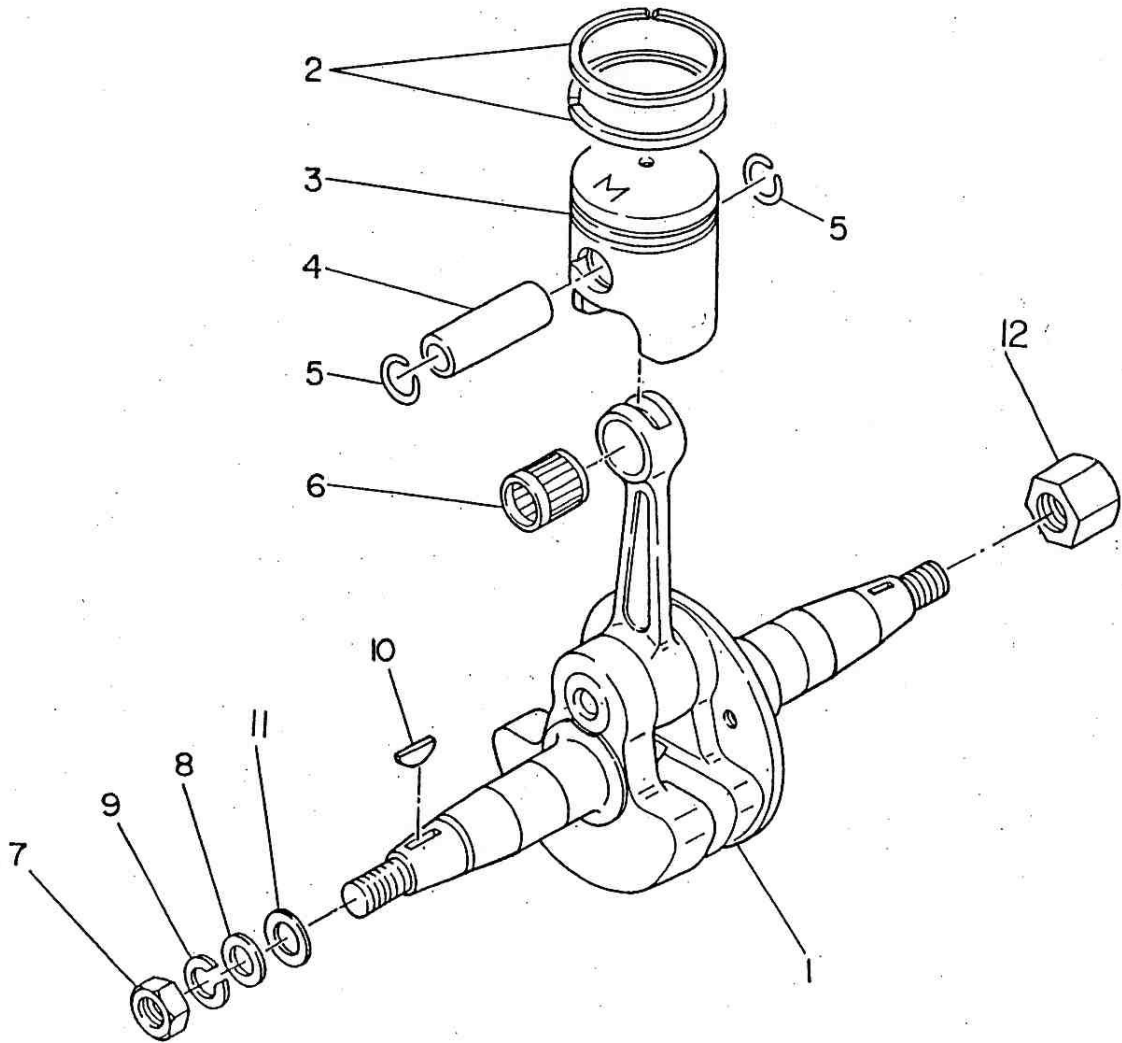
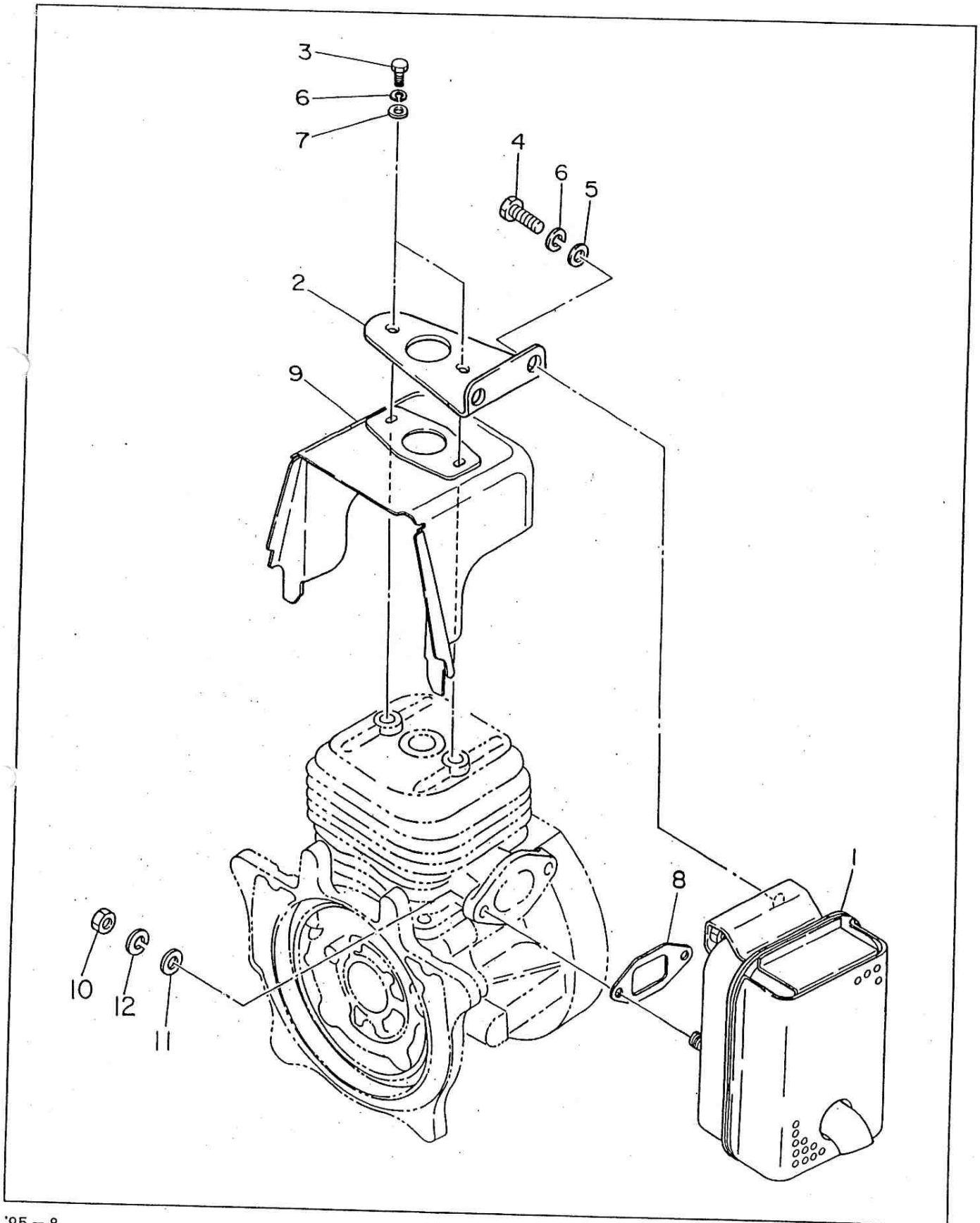



FIG. 3 MUFFLER





**FIG. 4 RECOIL STARTER and BLOWER HOUSING**

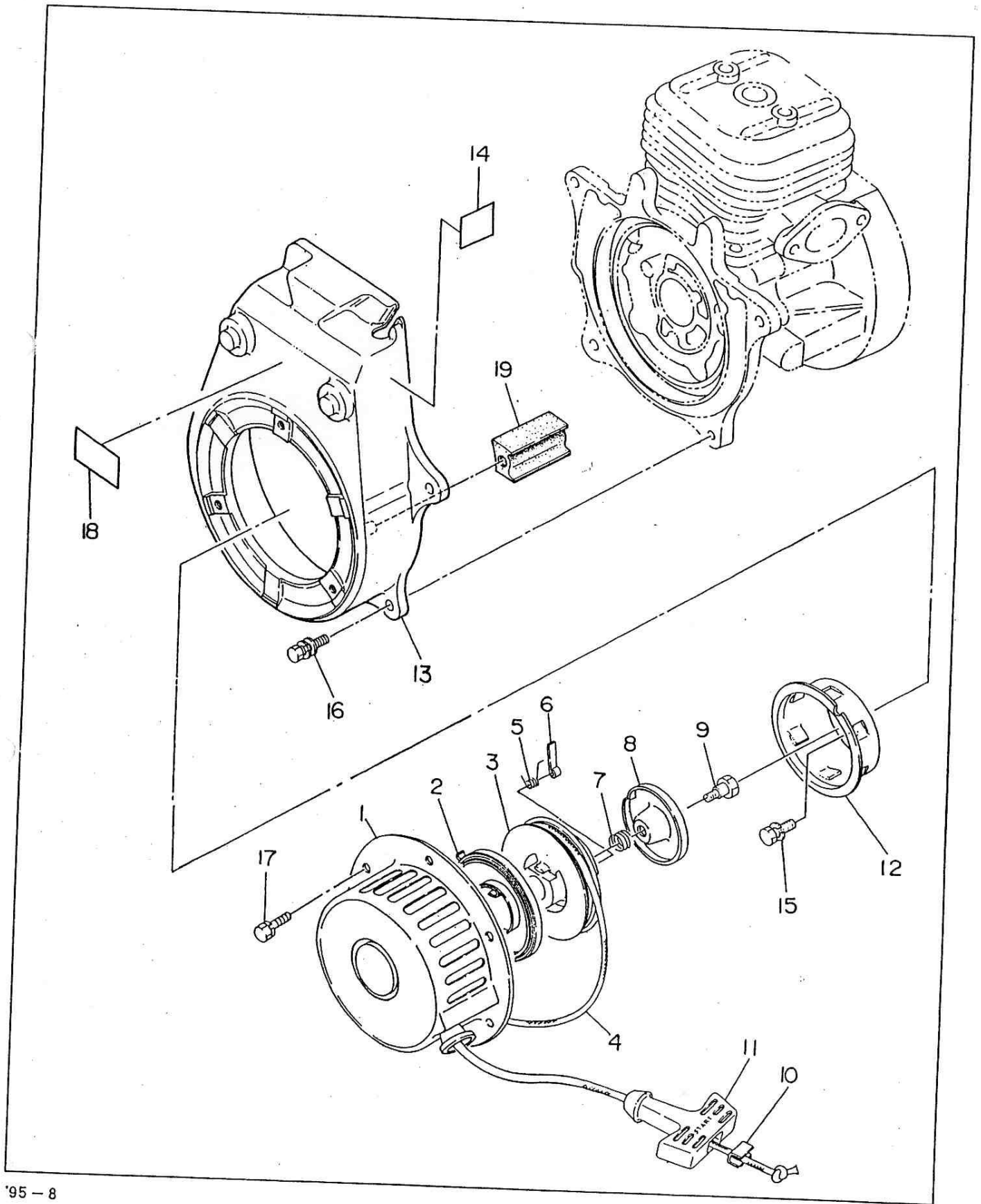
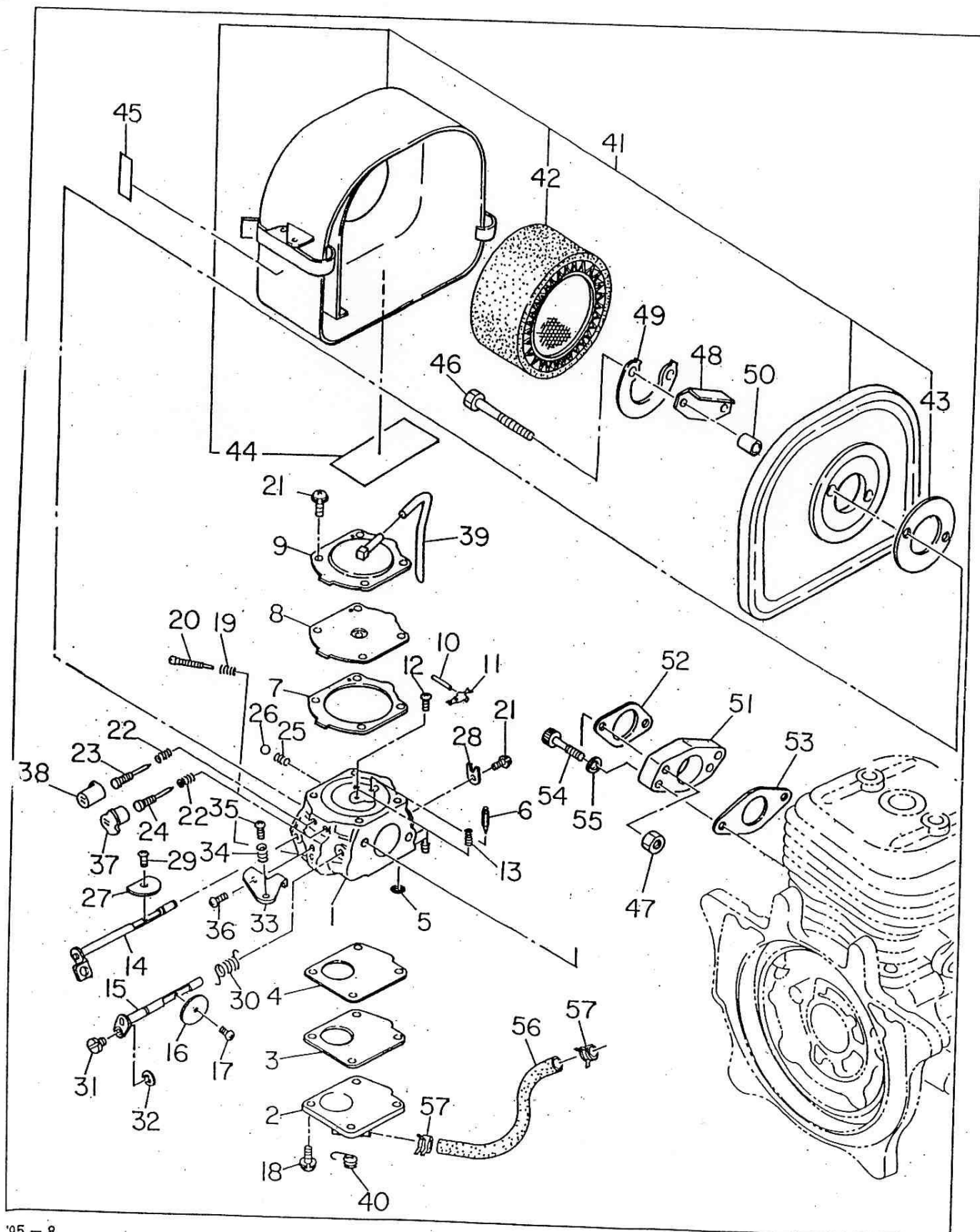



FIG. 5 CARBURETOR and AIR CLEANER



# FIG. 5 CARBURETOR and AIR CLEANER

Ref. No.	Parts Number	Description	Q'ty	Interchangeability	
					Execution
* 1	580 - 61090 - 00	CARBURETOR			
2	580 - 61020 - 10	COVER ASS'Y	1		Walbro WJ57 K
X 3	580 - 60841 - 50	GASKET	1		
X 4	580 - 60841 - 60	DIAPHRAGM	1		
5	501 - 60040 - 10	SCREEN	1		
X 6	501 - 60050 - 30	VALVE (inlet needle)	1		
X 7	580 - 60842 - 10	GASKET	1		
X 8	580 - 60842 - 20	DIAPHRAGM ASS'Y	1		
9	580 - 61090 - 10	COVER ASS'Y	1		
10	523 - 60270 - 10	PIN	1		
11	580 - 60841 - 40	LEVER (metering)	1		
12	501 - 60041 - 10	SCREW	1		
13	580 - 60840 - 30	SPRING	1		
14	580 - 61020 - 20	SHAFT ASS'Y (choke)	1		
15	580 - 61020 - 30	SHAFT ASS'Y (throttle)	1		
16	580 - 60840 - 60	VALVE (throttle)	1		
17	580 - 60842 - 40	SCREW	1		
18	580 - 60842 - 50	SCREW ASS'Y	1		
19	510 - 60452 - 20	SPRING	4		
20	580 - 60843 - 10	SCREW	1		
21	501 - 60041 - 60	SCREW ASS'Y	1		
22	580 - 60841 - 10	SPRING	5		
23	580 - 61021 - 60	NEEDL (high speed)	2		
24	580 - 61022 - 10	NEEDLE (idle)	1		
25	580 - 60843 - 20	SPRING	1		
26	580 - 60843 - 30	BALL	1		
27	580 - 60843 - 40	VALVE (choke)	1		
28	510 - 60450 - 40	CLIP	1		
29	510 - 60451 - 40	SCREW	1		
30	580 - 61021 - 20	SPRING	1		
31	524 - 60012 - 10	SWIVEL	1		
32	580 - 61020 - 40	RING	1		
33	580 - 61022 - 20	BRACKET	1		
34	580 - 61021 - 30	SPRING	1		
35	580 - 61021 - 40	SCREW	1		
36	580 - 61021 - 50	SCREW	1		
37	580 - 61020 - 50	CAP (limiter)	1		
38	580 - 61020 - 60	CAP (limiter)	1		
39	580 - 61090 - 20	HOSE	1		
40	580 - 61090 - 30	SUPPORT, HOSE	1		
* 41	106 - 32727 - 20	CLEANER, AIR	1		
42	106 - 32704 - 07	ELEMENT SET	1		
43	106 - 32723 - 08	PACKING	1		
44	106 - 32738 - 08	LABEL	1		

FIG. 5 CARBURETOR and AIR CLEANER

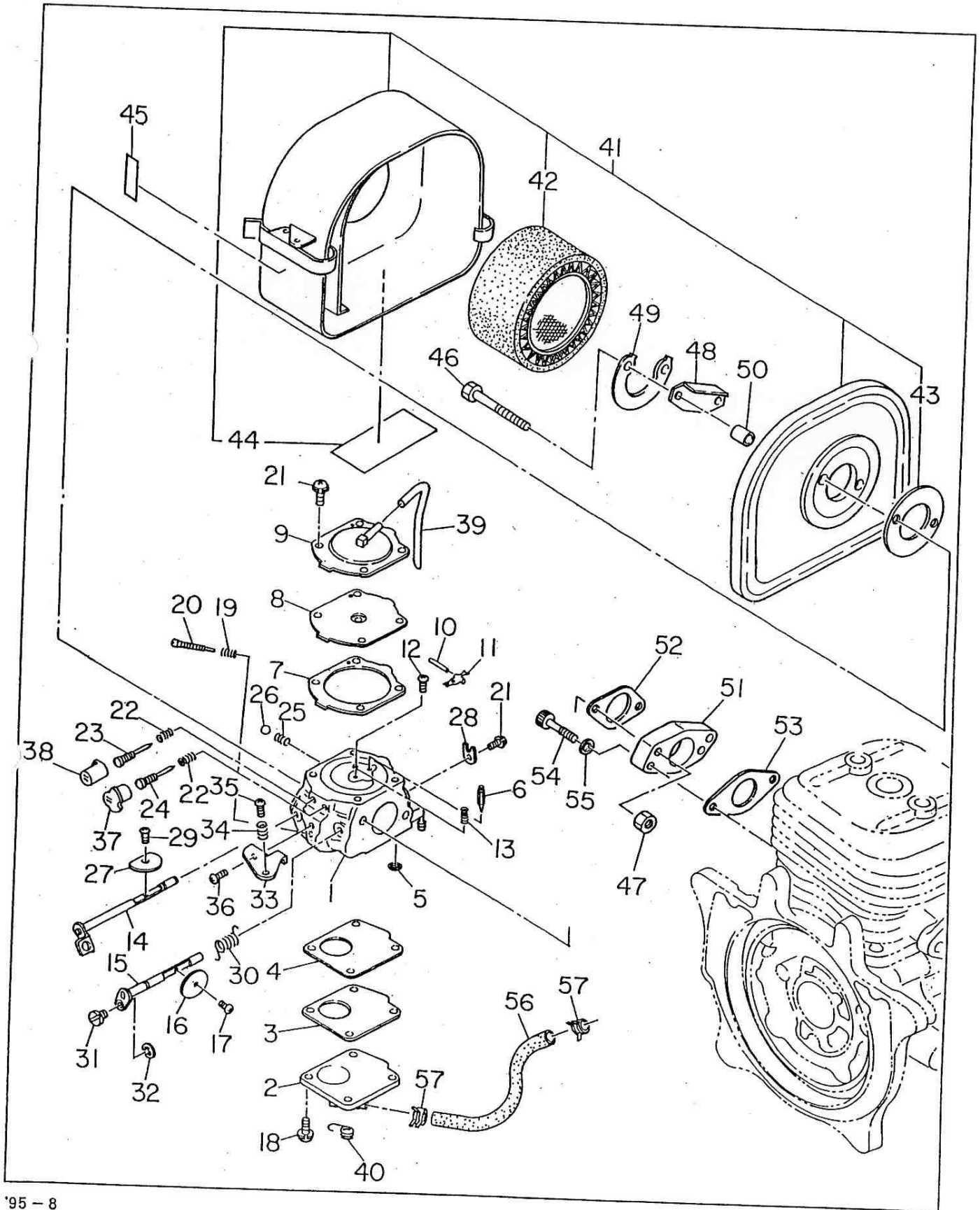



FIG. 6 ELECTRIC DEVICE

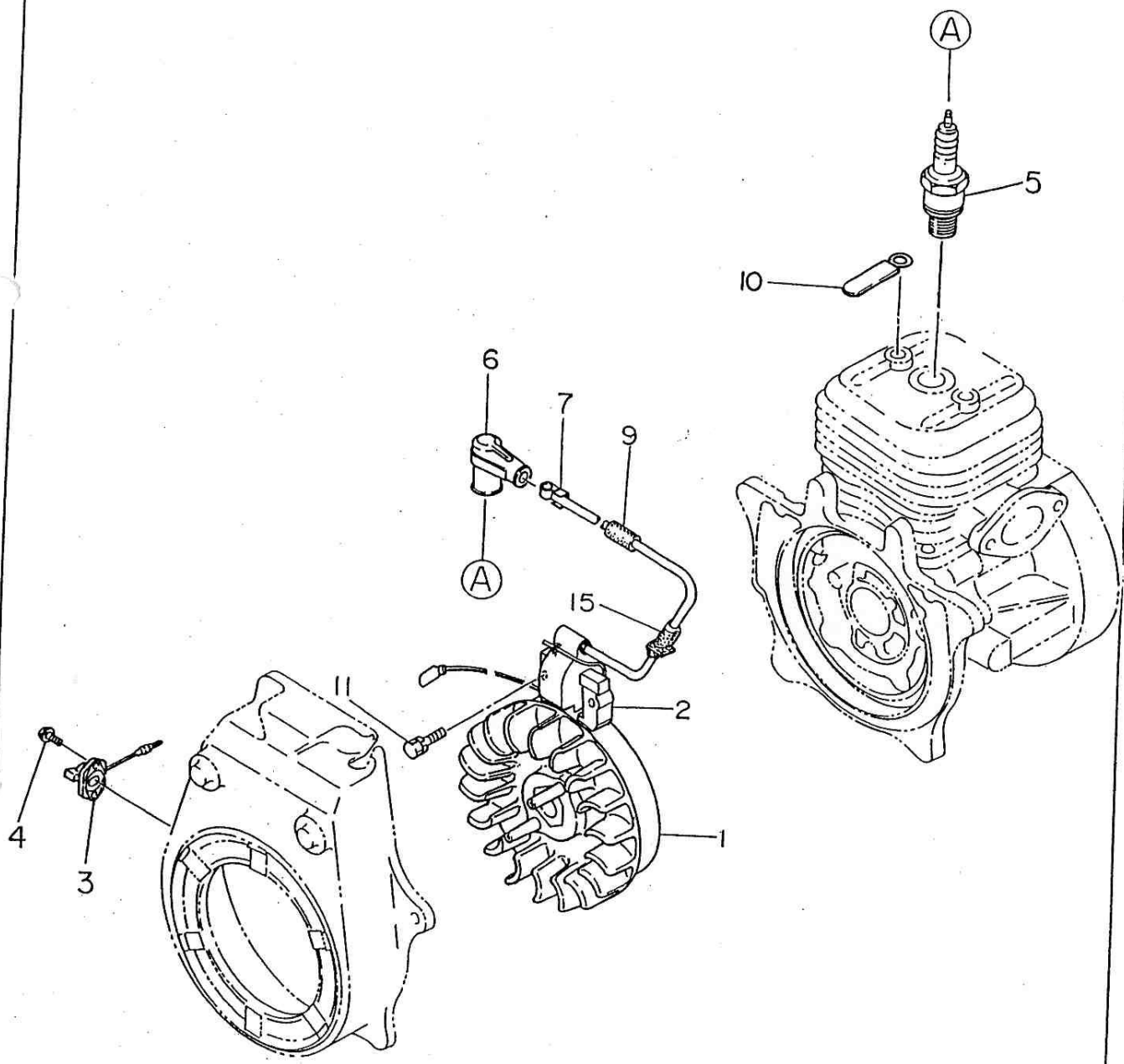



FIG. 7 ACCESSORIES

