



Robin Engine

Model EC10

for WEBER

PARTS CATALOG

Spec.No. EC100DD6800

 **富士重工業株式会社**
FUJI HEAVY INDUSTRIES LTD.

Fig. 100

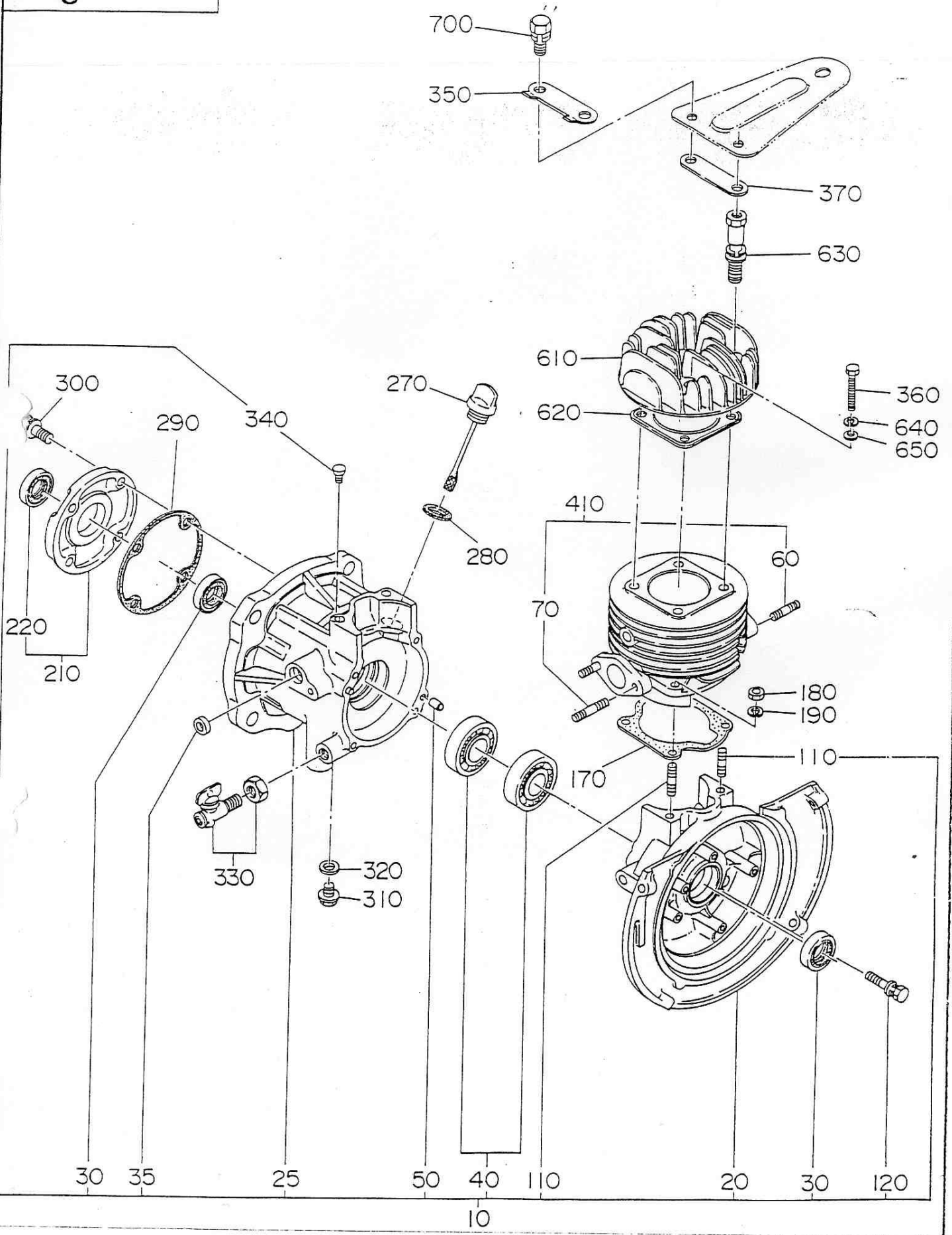

1 CRANKCASE

REF.	PART NUMBER	PART NAME	QTY	REMARKS	CODE NO. FROM-TO	INTERCHANGEABLE PART NUMBER	UNIT PRICE	FIG.
10	106-10715-01	CRANKCASE CP	1		2101-			100
	106-10711-01	CRANKCASE CP	1		-2100			100
20	106-10121-03	CRANKCASE 1	1		-			100
25	106-10705-03	CRANKCASE 2	1		2101-			100
	106-10701-23	CRANKCASE 2	1		-2100			100
30	044-02000-10	OIL SEAL	2	TB20328	-			100
35	044-00800-10	OIL SEAL	1	VC8144	-			100
40	060-02000-20	BALL BEARING	2	BB6204C3	-			100
50	031-00600-10	DOWEL PIN	2		-			100
60	001-31083-01	STUD	2		-			100
70	001-31063-01	STUD	2		-			100
110	010-50700-10	STUD	4		-			100
120	013-00601-00	BOLT AND WASHER AY	4		-			100
170	106-15001-23	GASKET (CYLINDER)	1		-			100
180	017-00700-20	NUT	4		-			100
190	020-30700-10	SPRING WASHER	4		-			100
210	106-11602-01	CRANKCASE COVER CP	1		2101-			100
	106-11601-11	CRANKCASE COVER CP	1		-2100			100
220	044-02000-90	OIL SEAL	1	TC20327	2101-	TC20328		100
	044-02000-30	OIL SEAL	1	TB20328 (HS70)	-2100			100
270	106-63606-01	OIL GAUGE CP	1		-			100
280	021-01600-10	GASKET	1		-			100
290	106-15002-03	GASKET (CASE COVER)	1		-			100
300	013-00601-30	BOLT AND WASHER AY	4		-			100
310	040-10800-10	PLUG	1		-	040-10800-11		100
320	021-00800-10	GASKET	1		-			100
330	064-30001-01	DRAIN COCK	1		-			100
340	067-00701-00	AIR BREATHER	1		-2100			100
350	105-65101-21	LOCK WASHER CP	1		-			100
360	010-30800-10	BOLT	2		-			100
370	106-35302-01	SPACER CP	1		-			100
410	106-12405-11	CYLINDER CP	1		-			100
610	106-13001-13	CYLINDER HEAD	1		-			100
620	106-15101-11	GASKET CP (HEAD)	1		-			100
630	013-00800-71	BOLT AND WASHER AY	2		-			100
640	003-20080-00	SPRING WASHER	2		-			100

Fig. 200

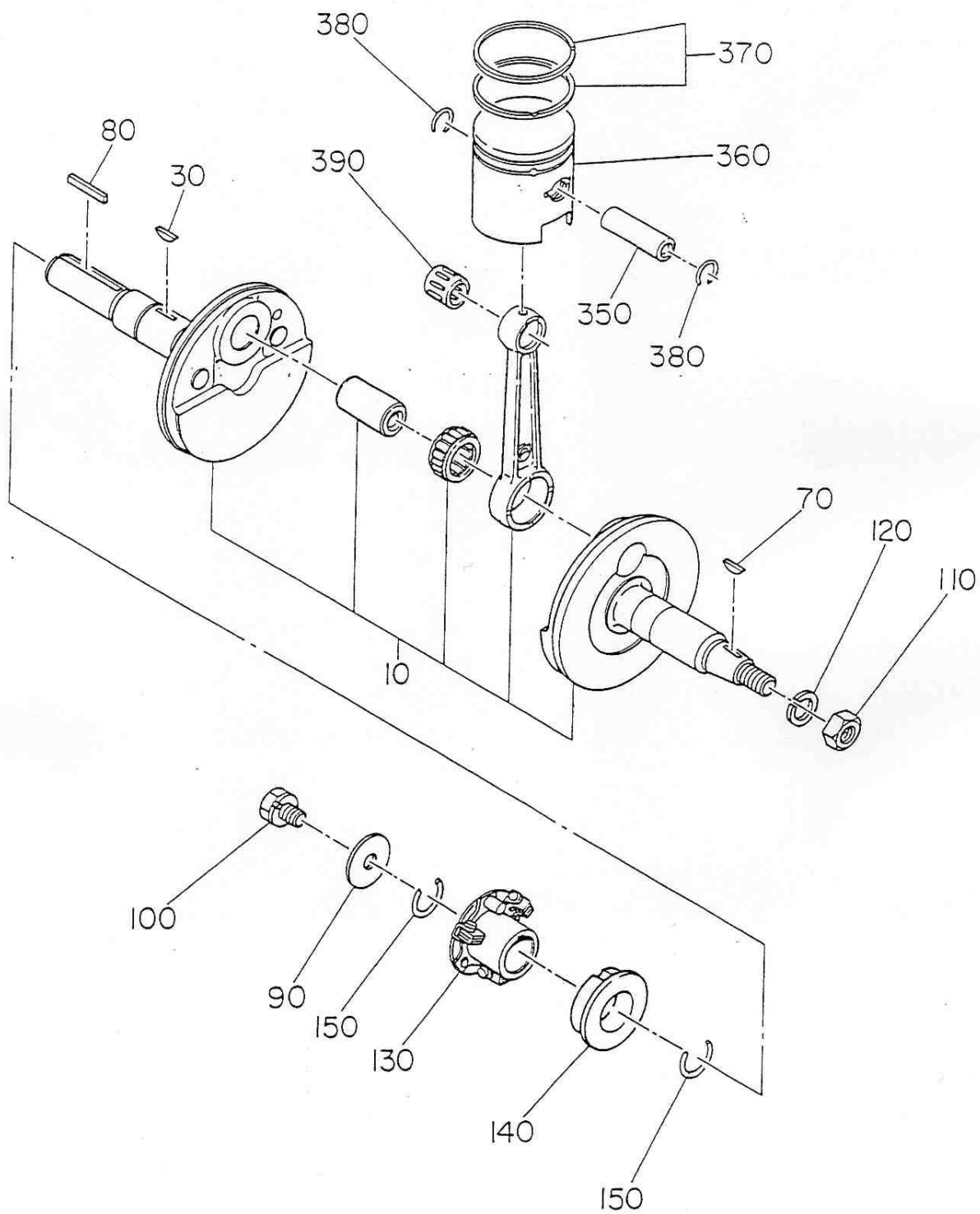

Fig. 300

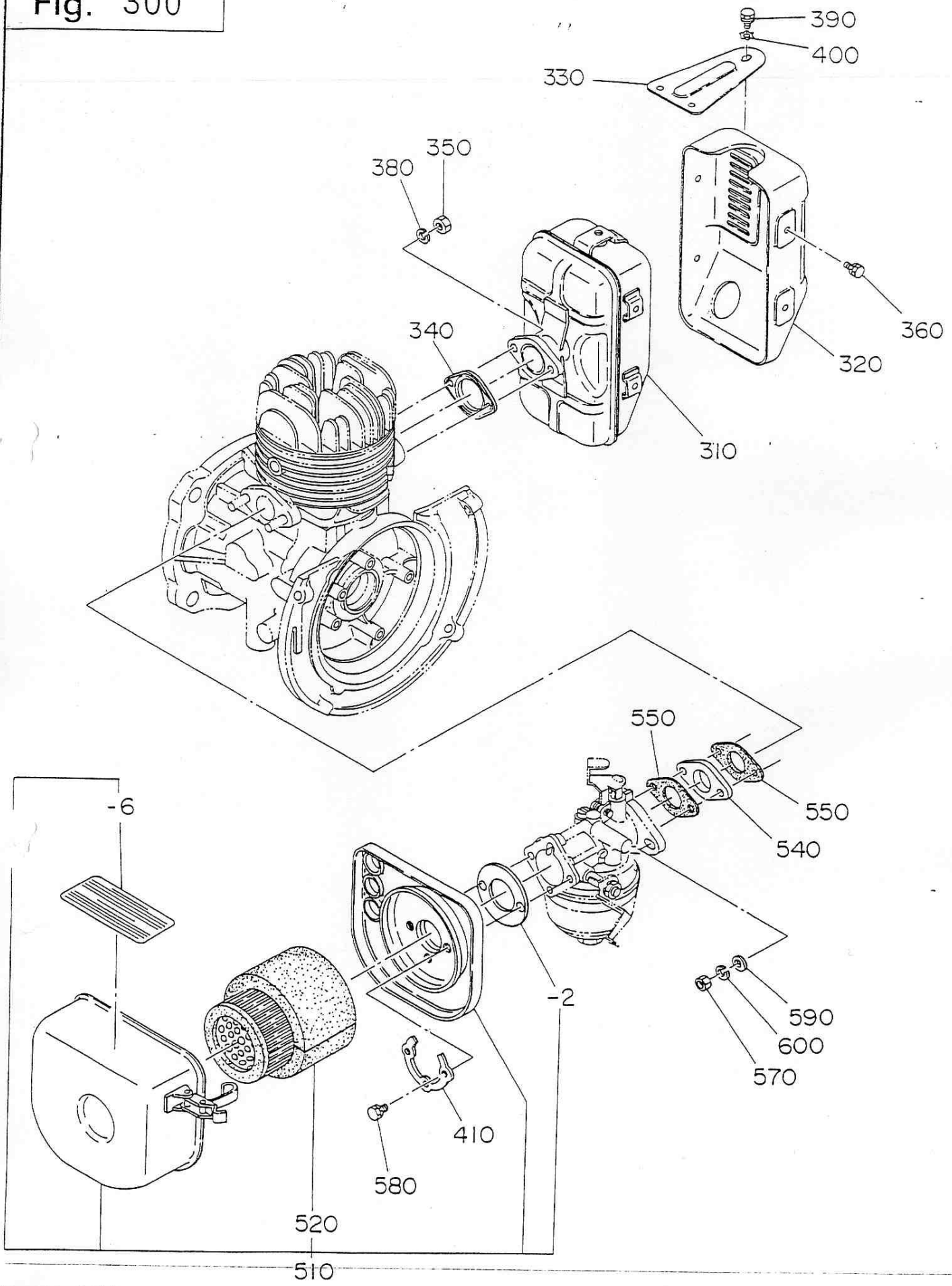

Fig. 400

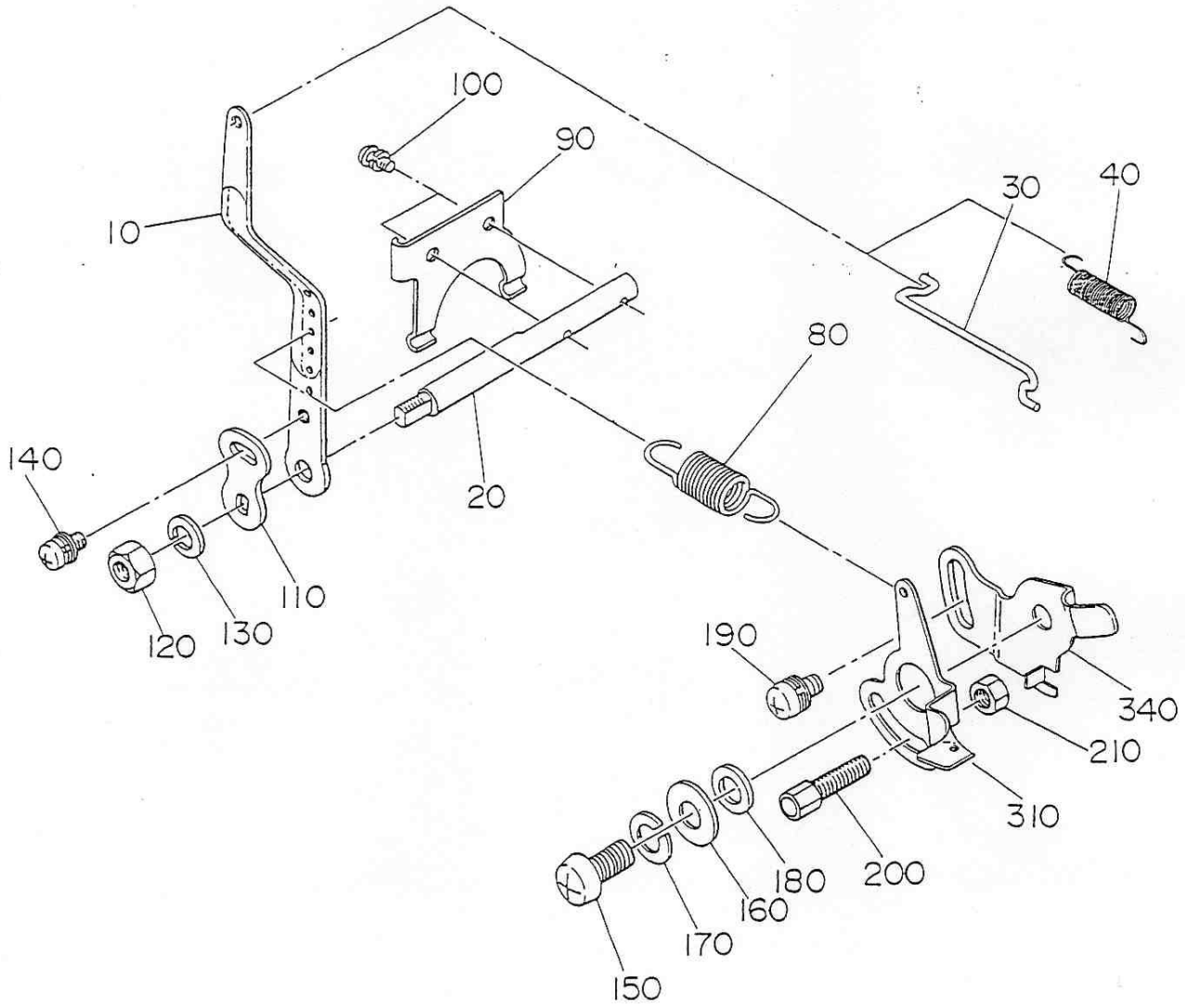

Fig. 500

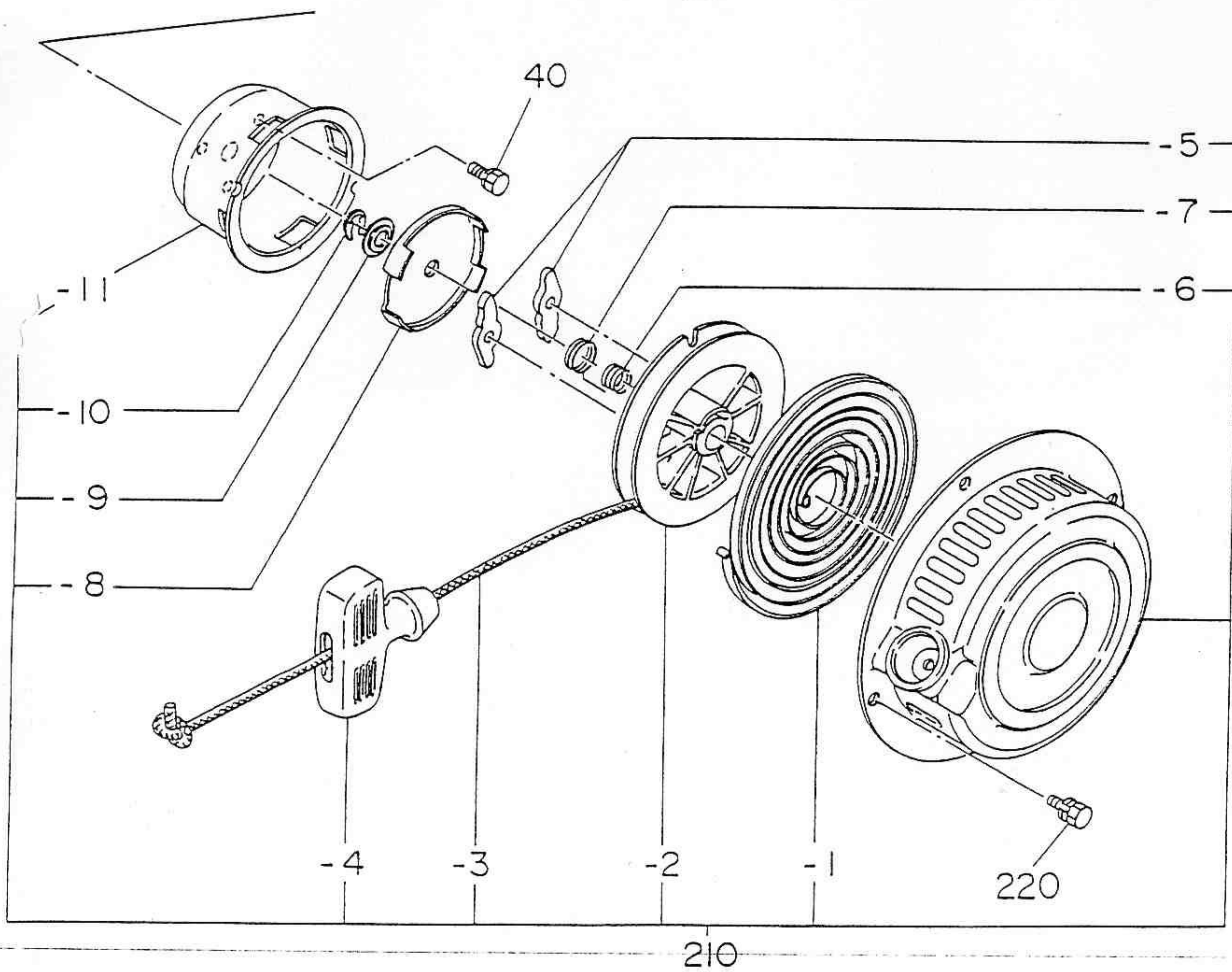
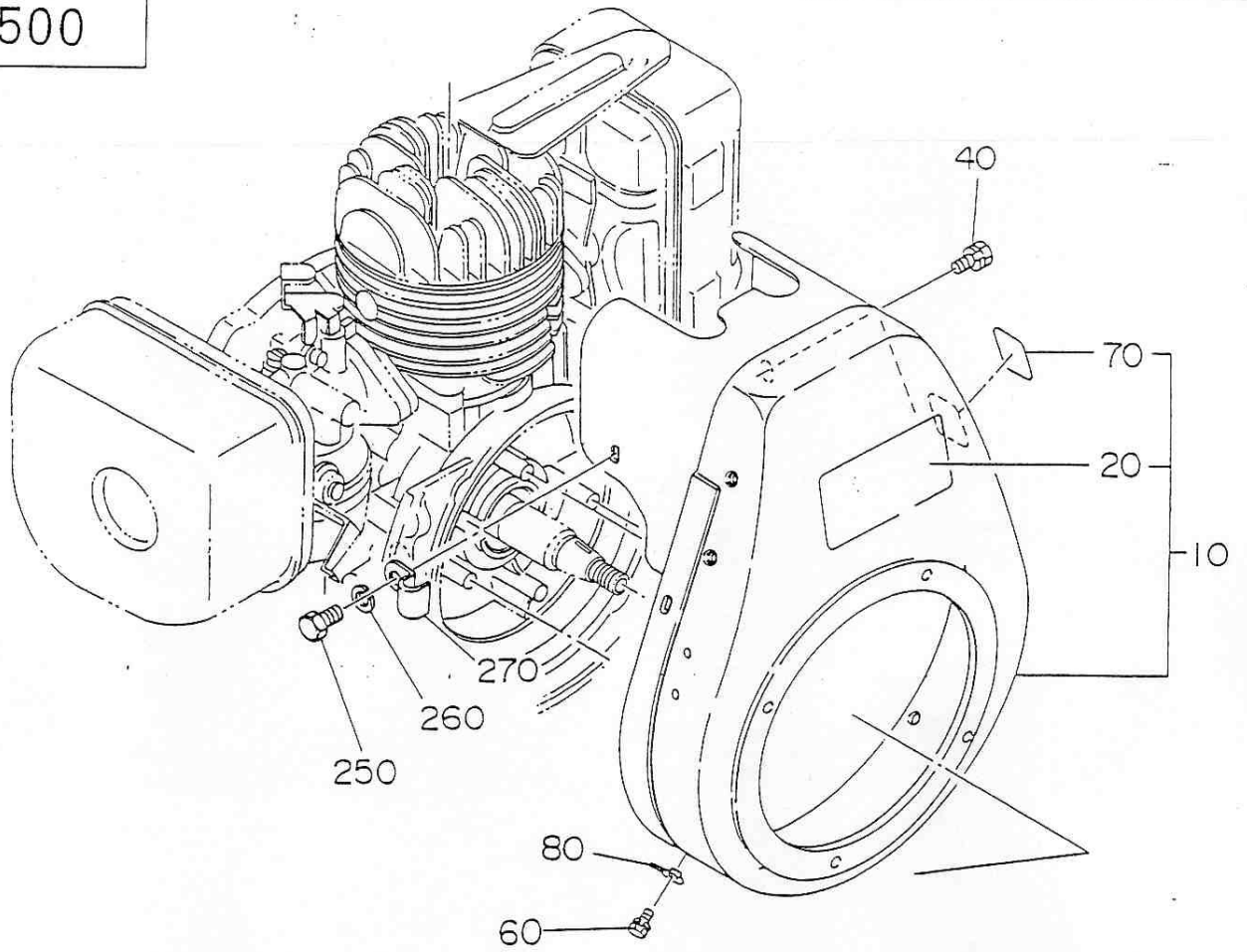
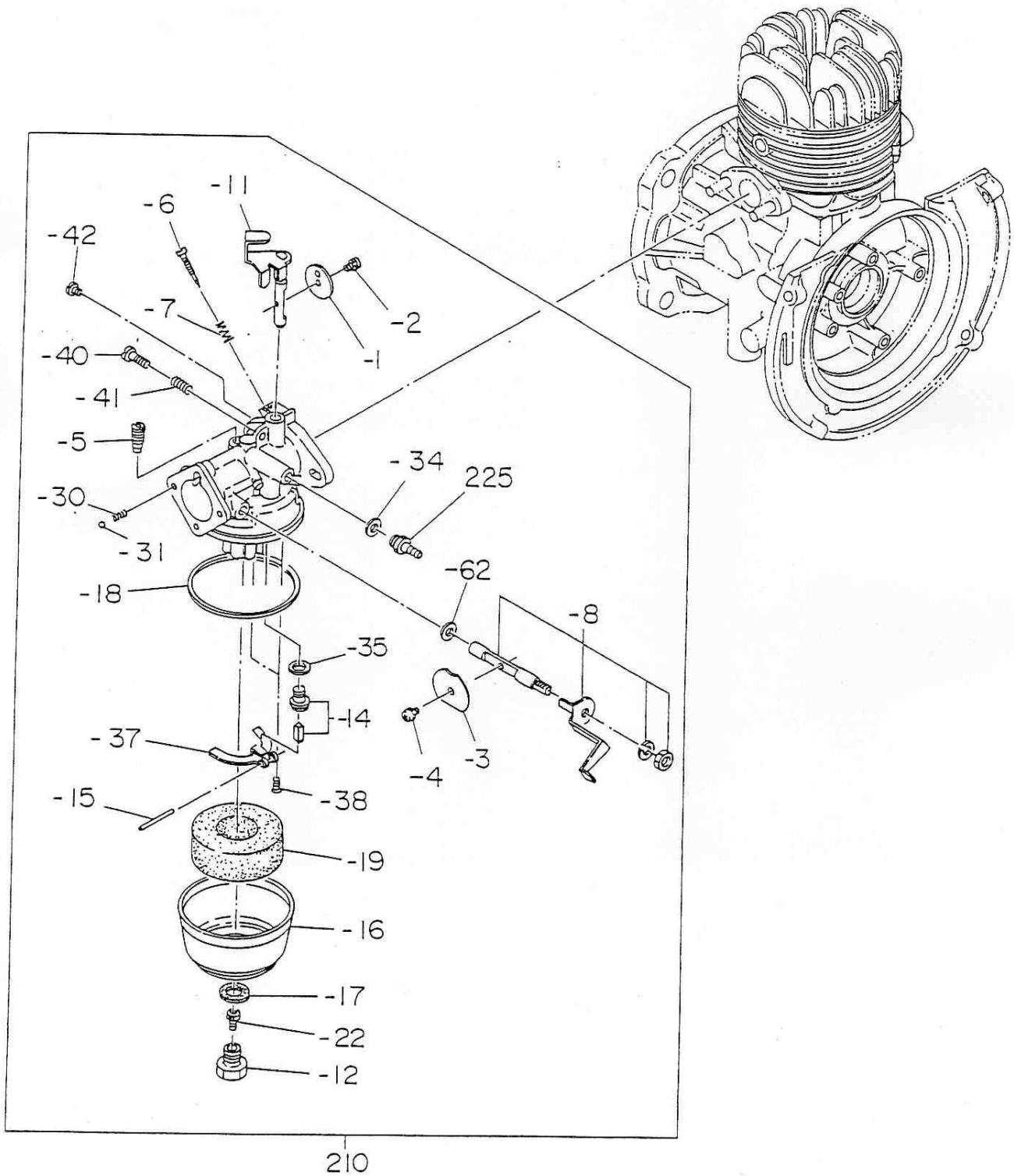

Fig. 600



6 FUEL. LUBRICANT :

REF.	PART NUMBER	PART NAME	QTY	REMARKS	CODE NO. FROM-TO	INTERCHANGEABLE PART NUMBER	UNIT PRICE	FIG.
210	106-62516-00	CARBURETOR AY	1		-			600
- 1	106-62538-08	THROTTLE VALVE	1		-			600
- 2	209-62351-08	SCREW	1		-			600
- 3	106-62527-08	CHOKE VALVE	1		-			600
- 4	209-62351-08	SCREW	1		-			600
- 5	207-62420-08	PILOT JET	1		-			600
- 6	106-62436-08	PILOT SCREW	1		-			600
- 7	206-62446-08	SPRING	1		-			600
- 8	106-62553-08	SHAFT AY (CHOKE)	1		-			600
- 11	106-62534-08	SHAFT AY (THROTTLE)	1		-			600
- 12	206-62350-08	BOLT	1		-			600
- 14	128-62500-08	NEEDLE VALVE	1		-			600
- 15	106-62516-08	FLOAT PIN	1		-			600
- 16	106-62389-08	FLOAT CHAMBER	1		-			600
- 17	206-62431-08	PACKING	1		-			600
- 18	106-62547-08	PACKING	1		-			600
- 19	106-62508-08	FLOAT	1		-			600
- 22	207-62403-08	MAIN JET	1		-			600
- 30	209-62446-08	CHOKE SPRING	1		-			600
- 31	209-62353-08	STEEL BALL	1		-			600
- 34	207-62345-08	INSERT WASHER	1		-			600
- 35	106-62381-08	WASHER	1		-			600
- 37	106-62511-08	FLOAT ARM	1		-			600
- 38	130-62358-08	SCREW	2		-			600
- 40	106-62358-08	SCREW	1		-			600
- 41	206-62446-08	SPRING	1		-			600
- 42	106-62357-08	GUIDE SCREW	1		-			600
- 62	106-62392-18	SEAL	1		-			600
225	050-50800-30	UNION	1		-			600

Fig. 700

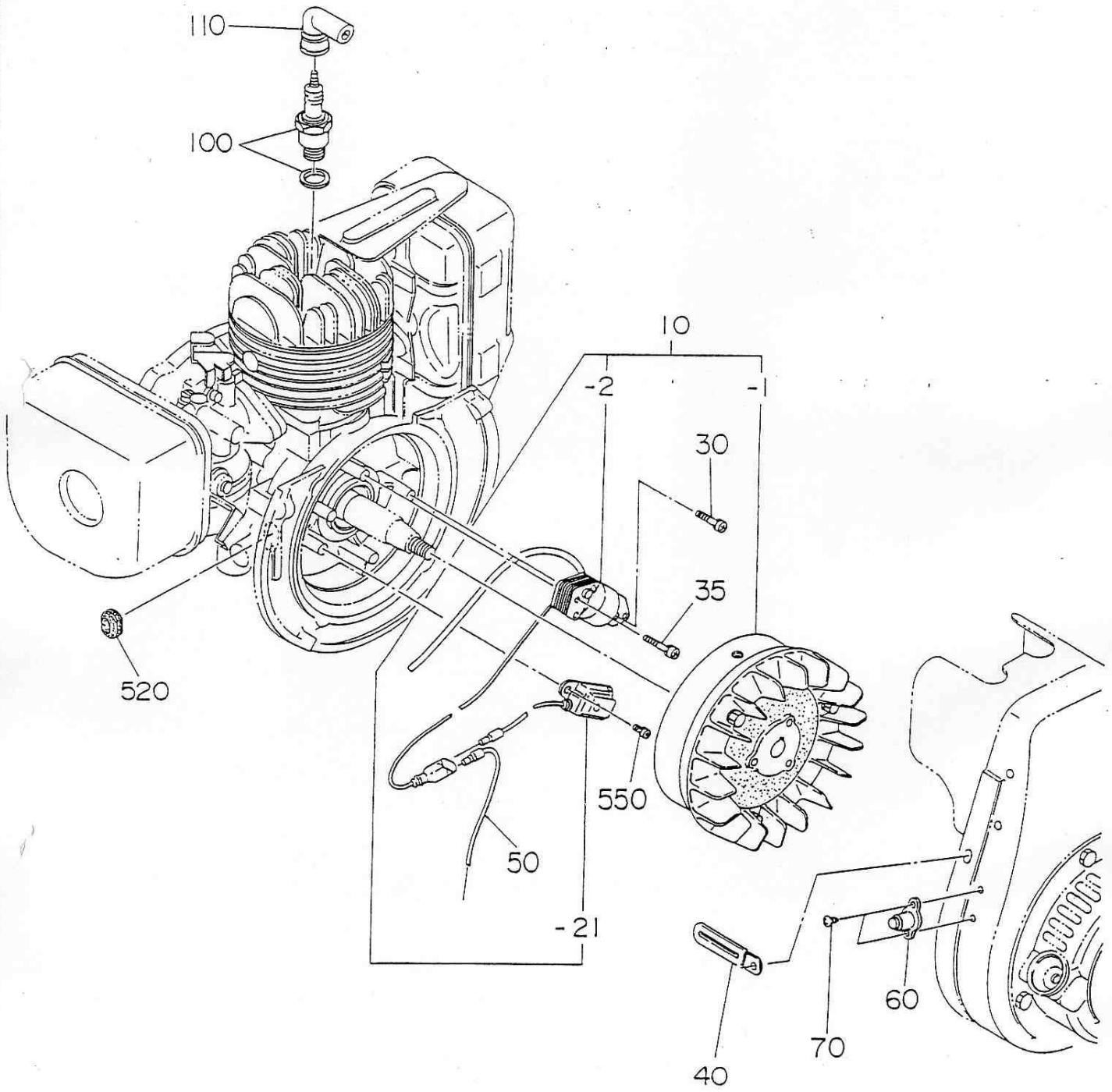

Fig. 900

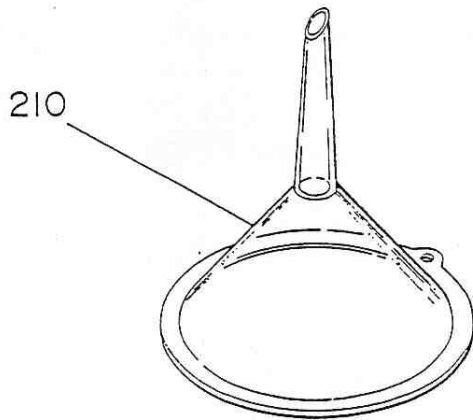
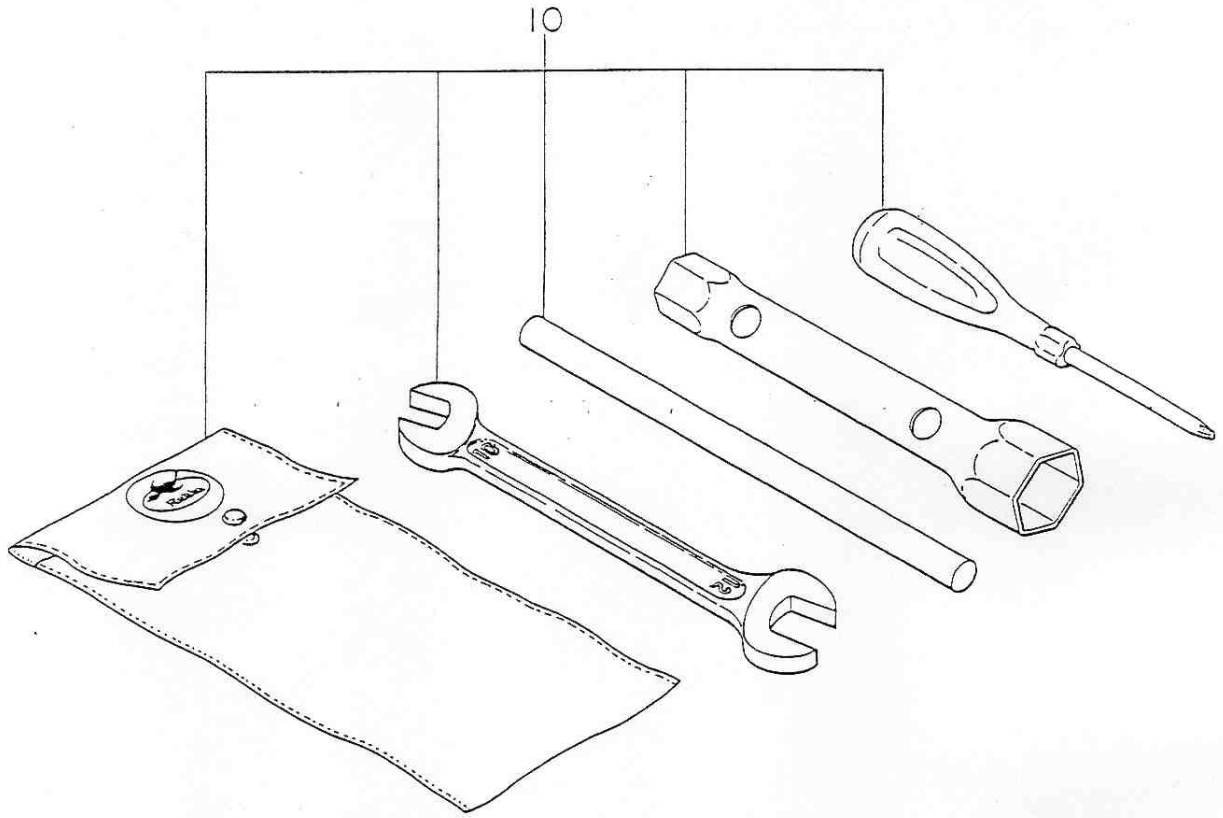

Fig. 1000

