

Robin Generator

Model **RGX5100**

PARTS CATALOG

Spec. No. RGM51053000

(Engine Spec.No.EX300D20060)

FUJI HEAVY INDUSTRIES LTD.

ISSUE EMD-GP6796	
ISSUE DATE	2009.07

CONTENTS

FIG.	
100	CRANKCASE
200	CRANKSHAFT PISTON
300	INTAKE EXHAUST
330	AIR CLEANER
400	GOVERNOR OPERATION
500	COOLING STARTING
600	FUEL LUBRICANT
700,740	ELECTRIC DEVICE
2130	ENGINE AY
2200	GENERATOR
2300	BASE FRAME
2400	CONTROL
2600	FUEL TANK
2900	ACCESSORIES

FIG. 100

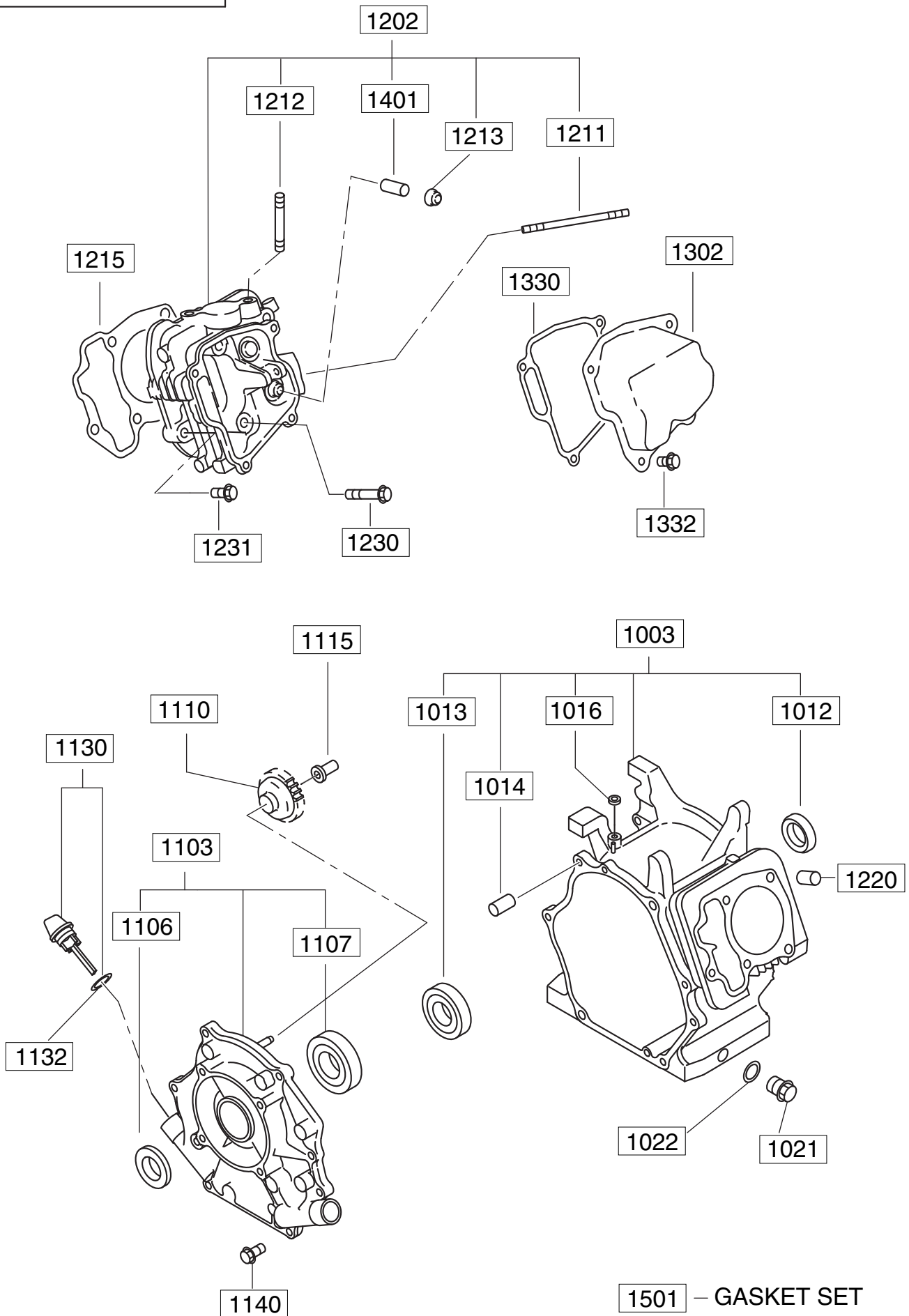

FIG. 200

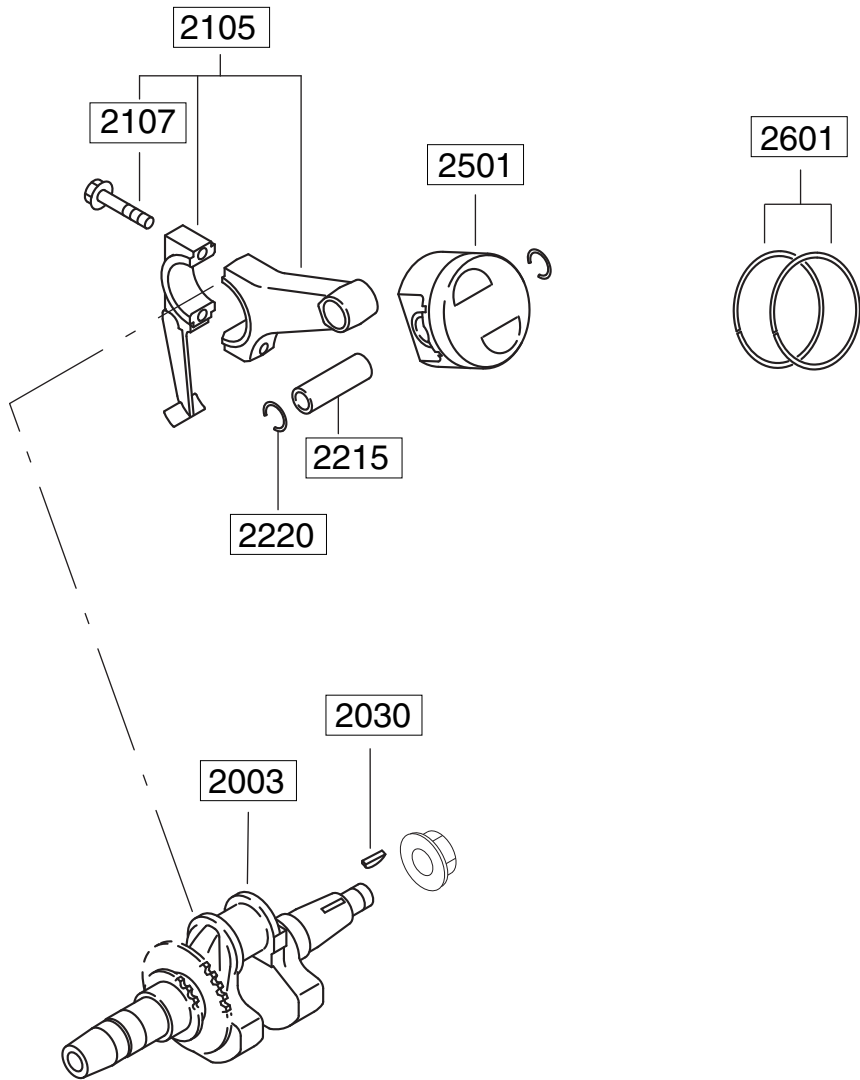

FIG. 300

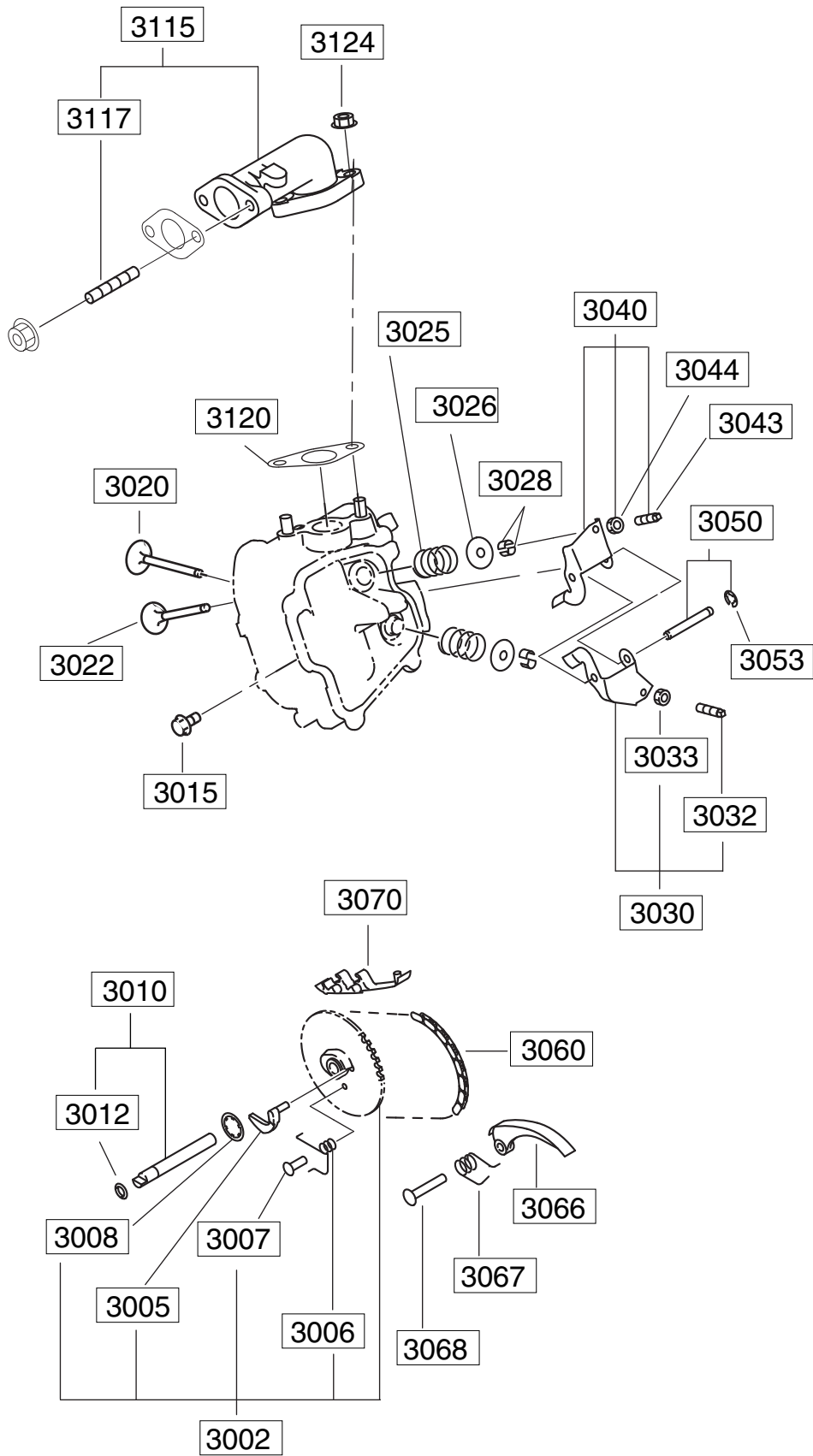

FIG. 330

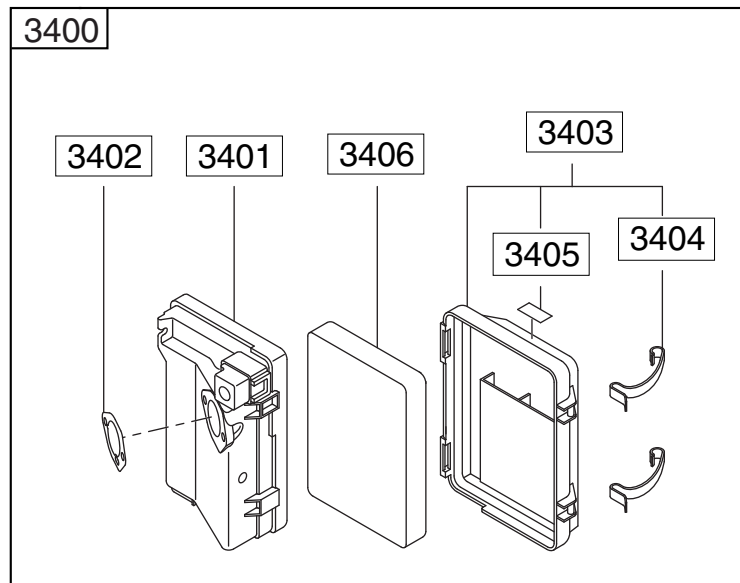
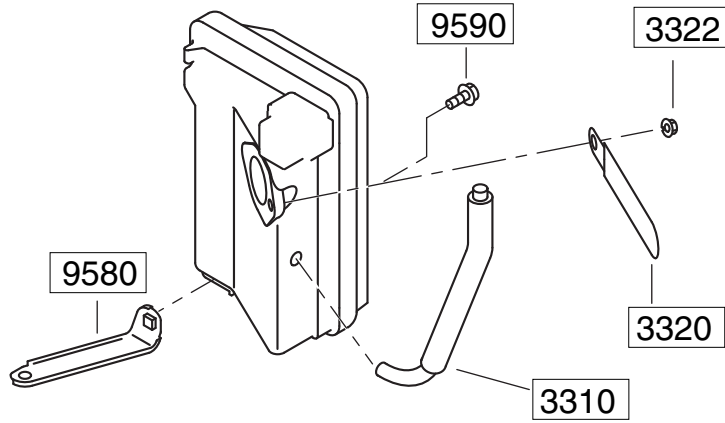

FIG. 400

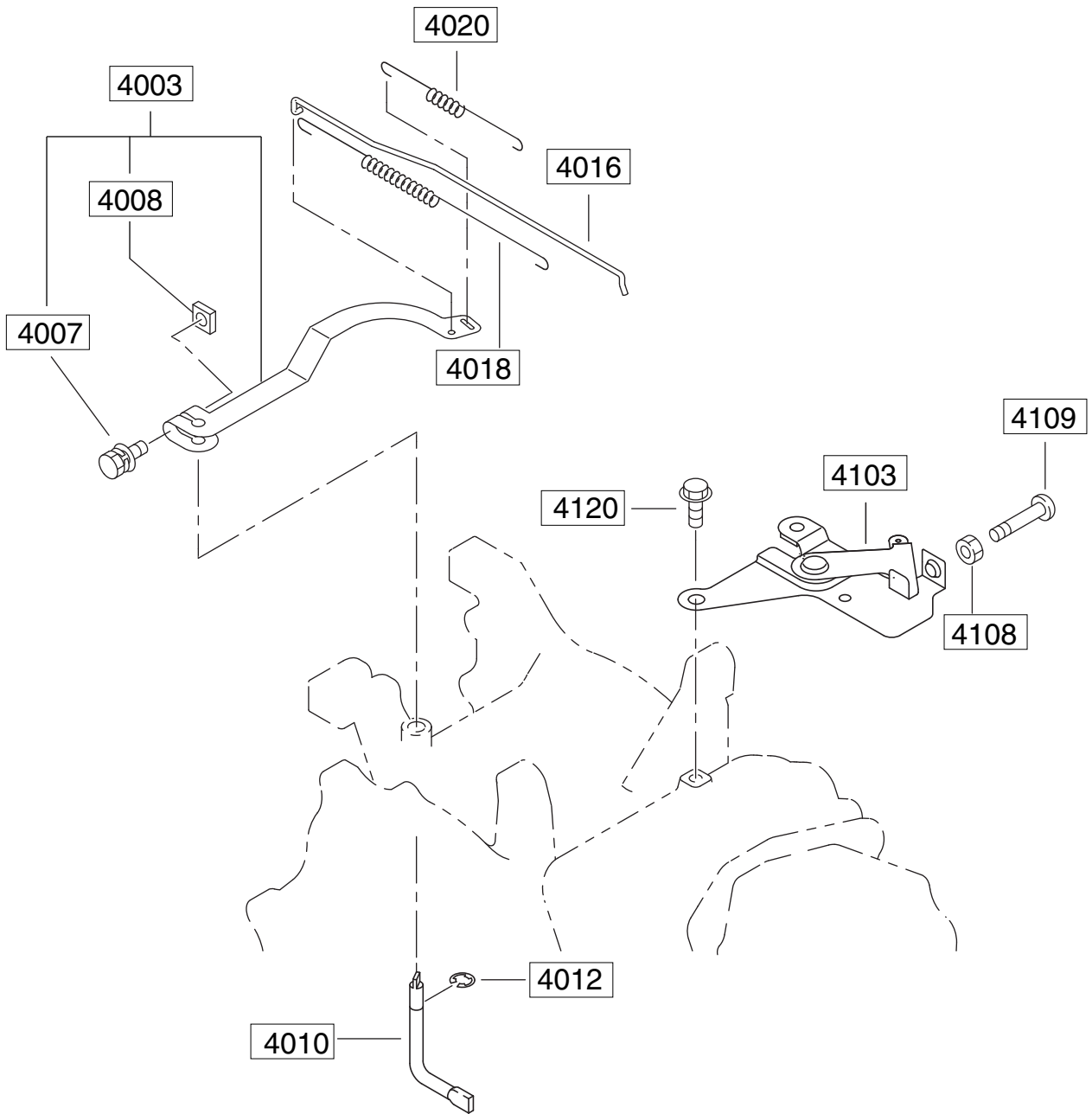

FIG. 500

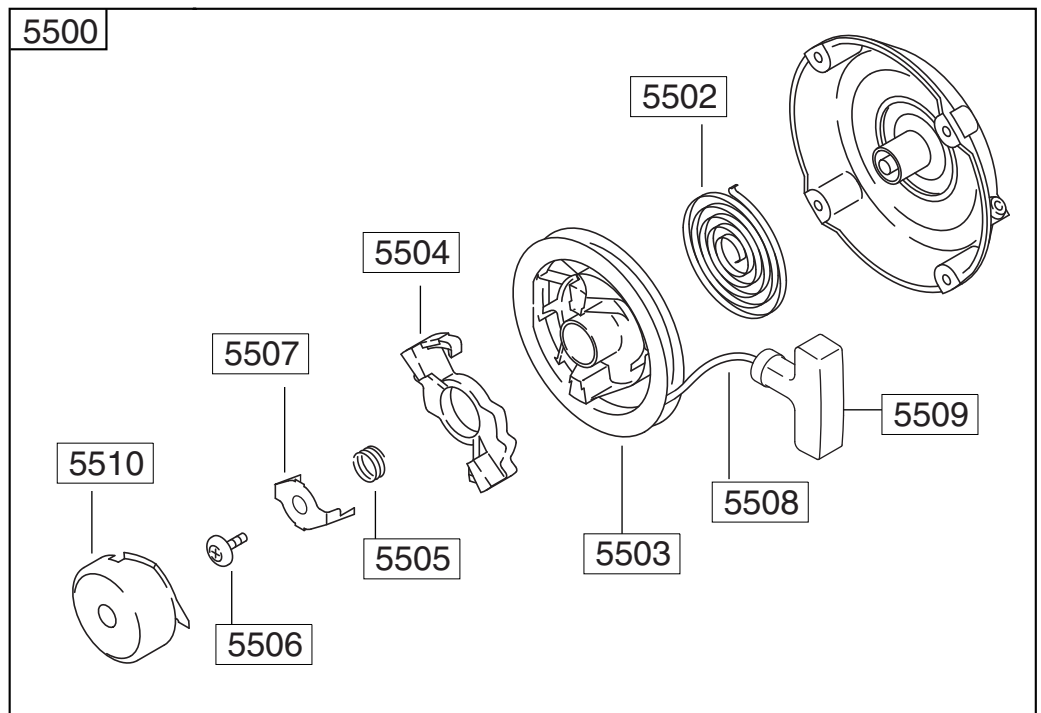
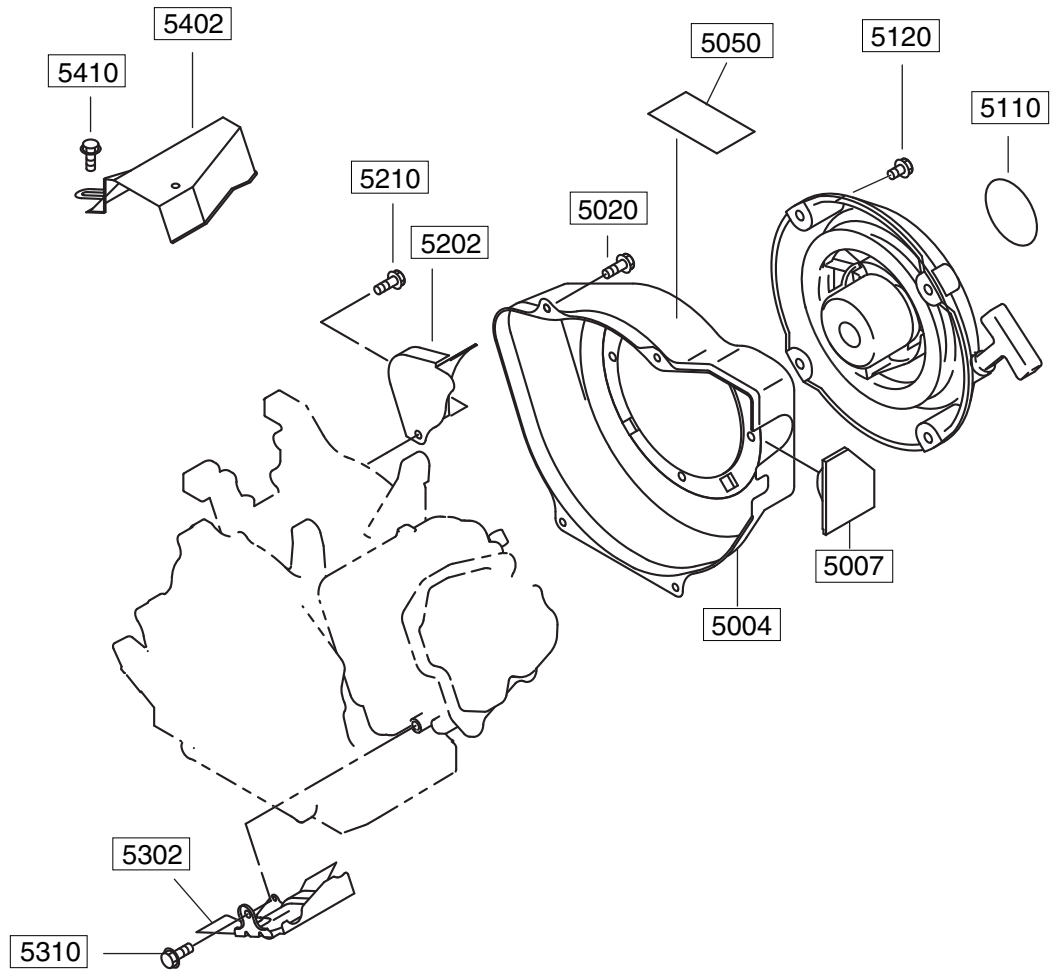

FIG. 600

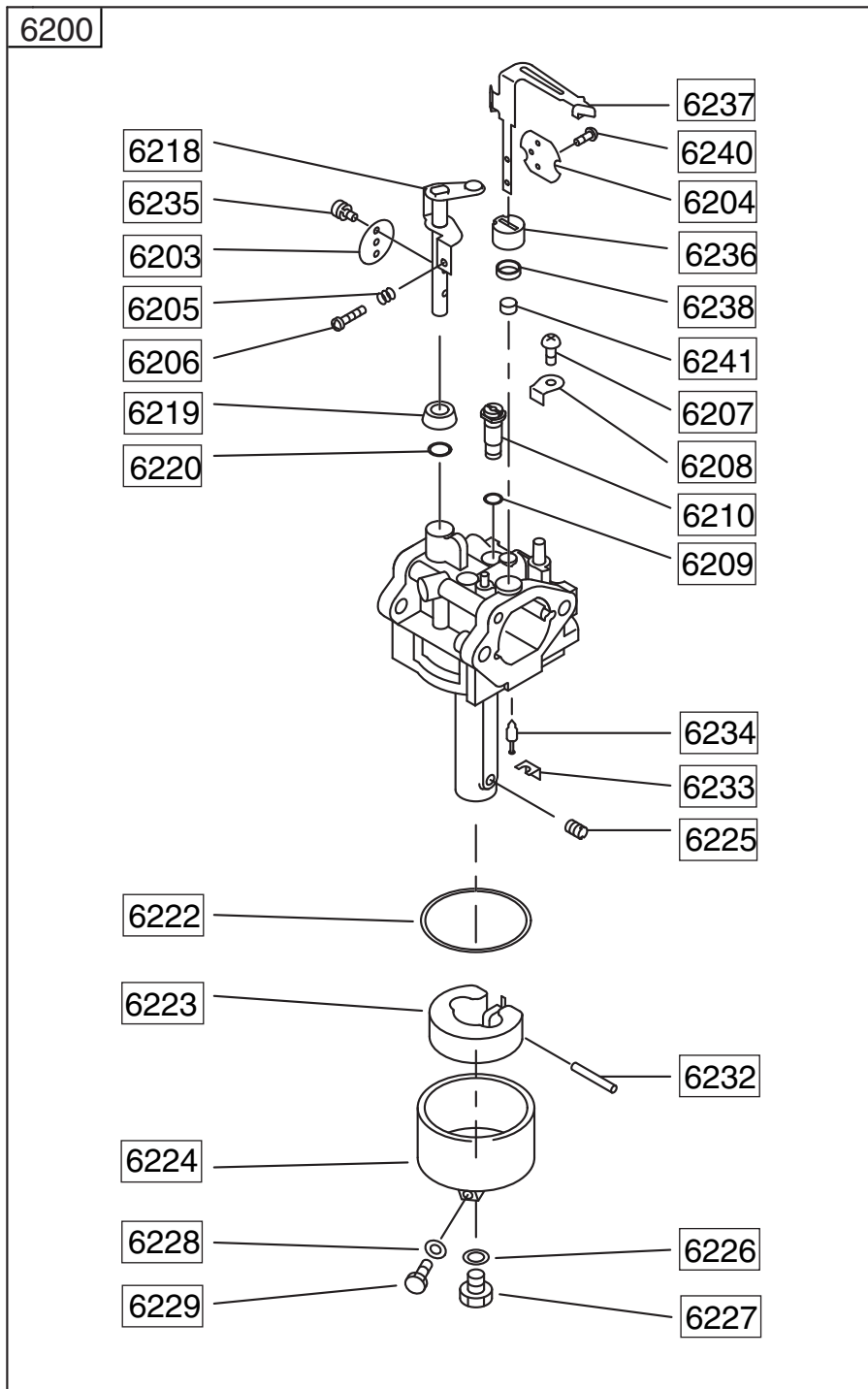
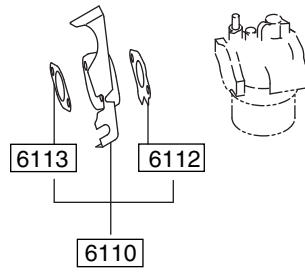
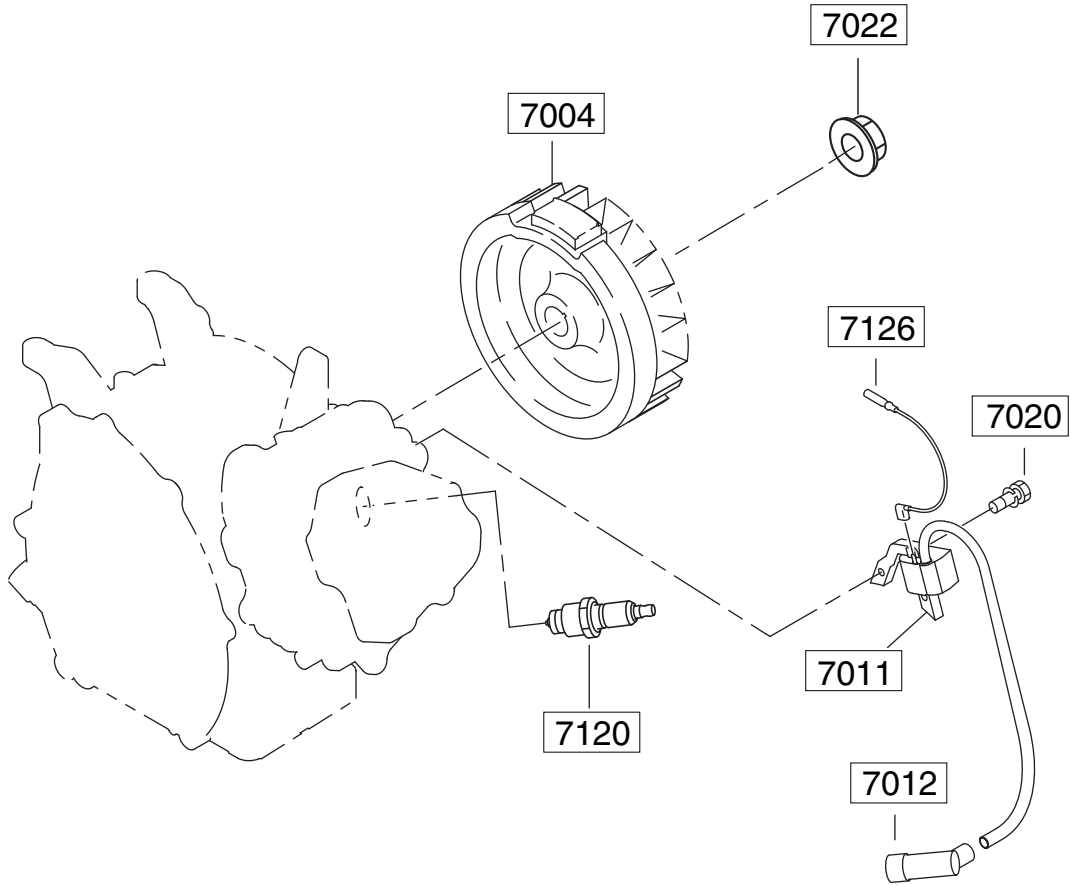

FIG. 700



OIL LEVEL SENSOR

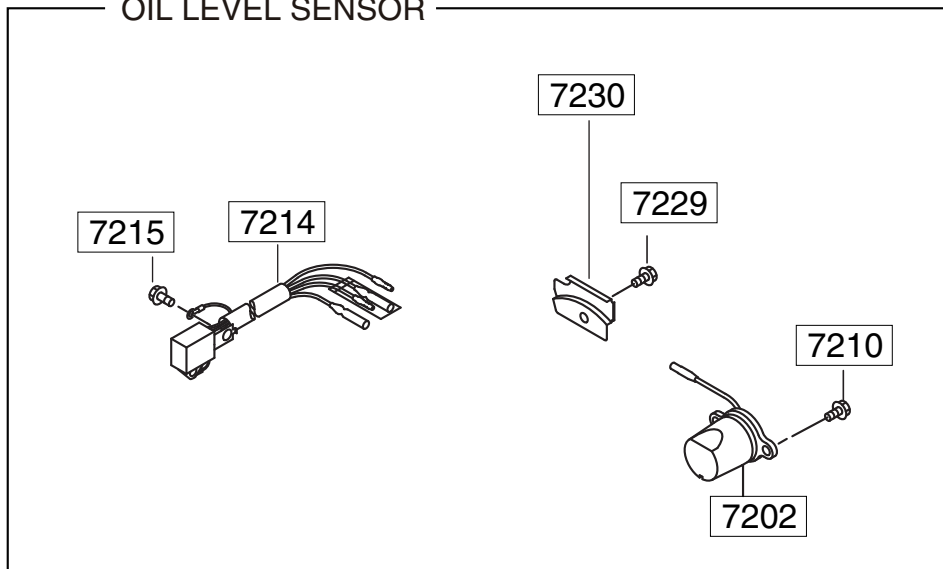

FIG. 740

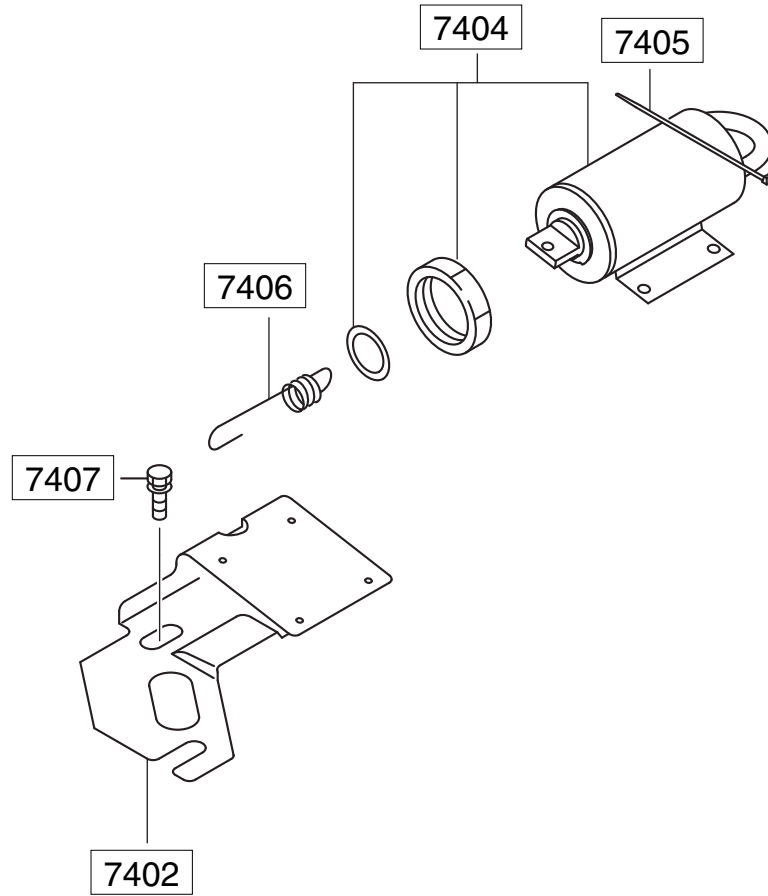

FIG. 2130

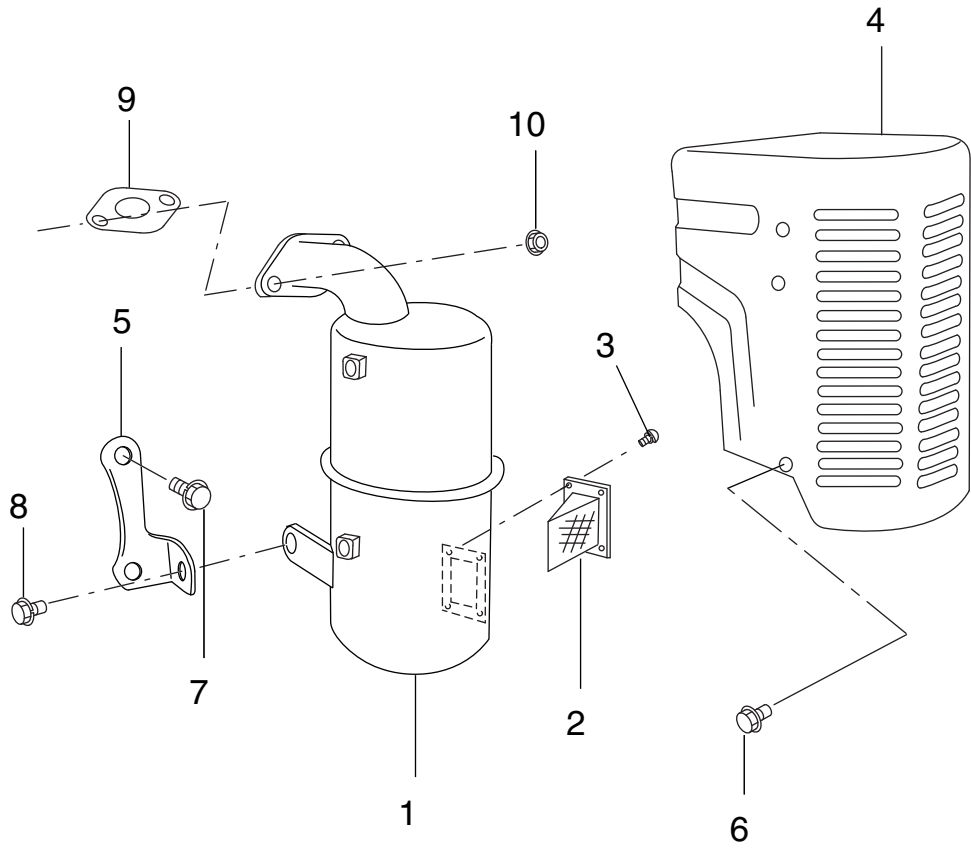

FIG. 2200

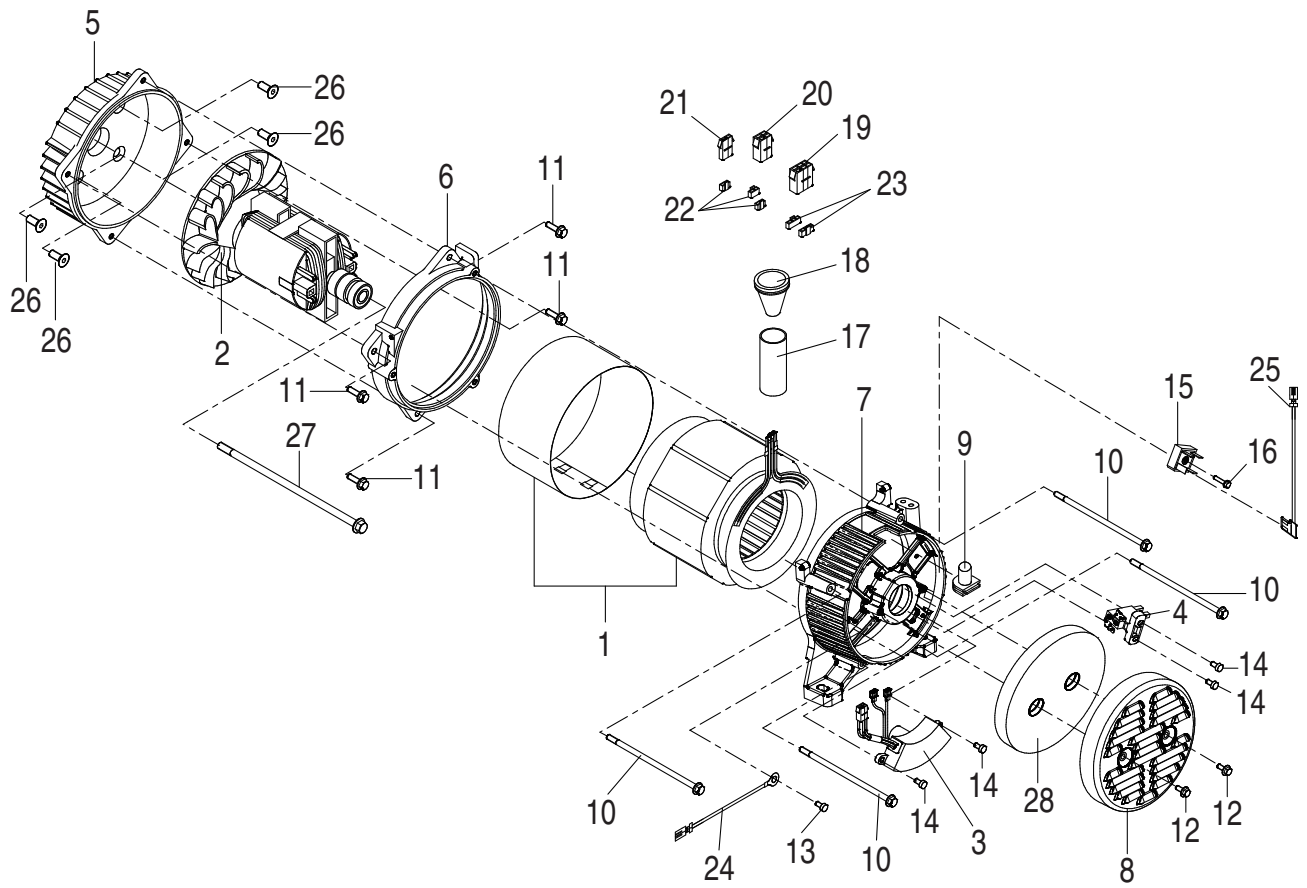

FIG. 2300

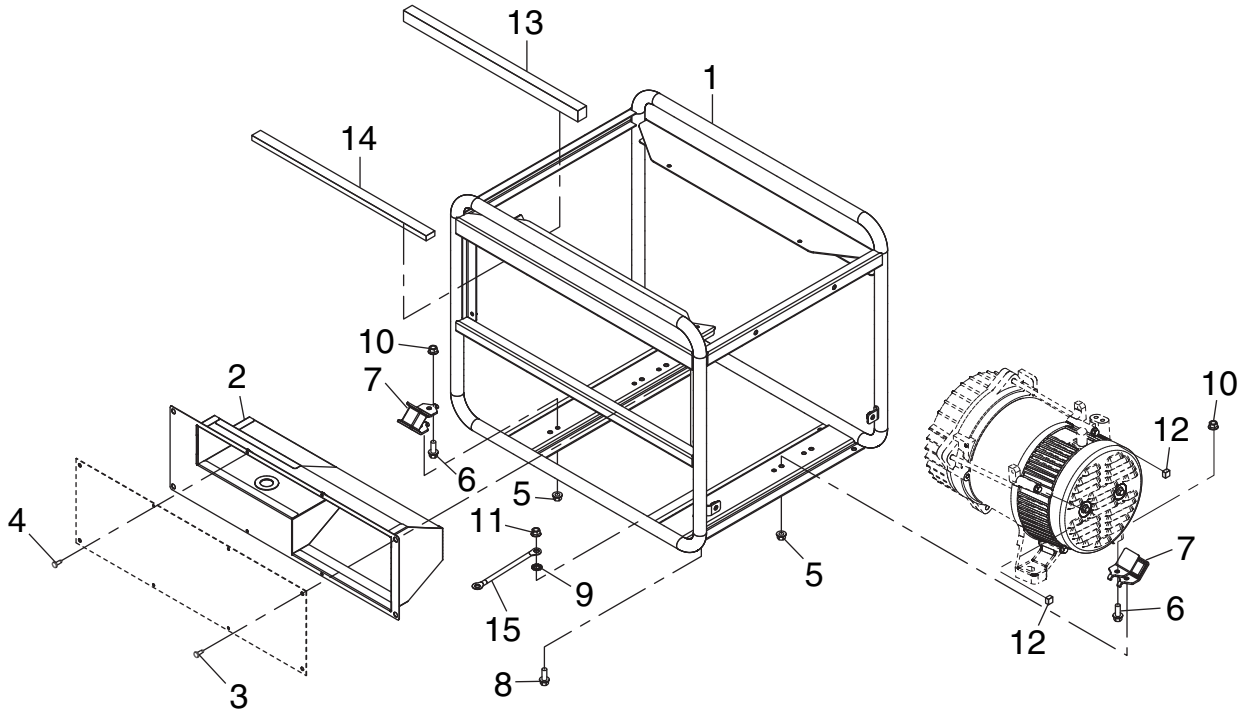
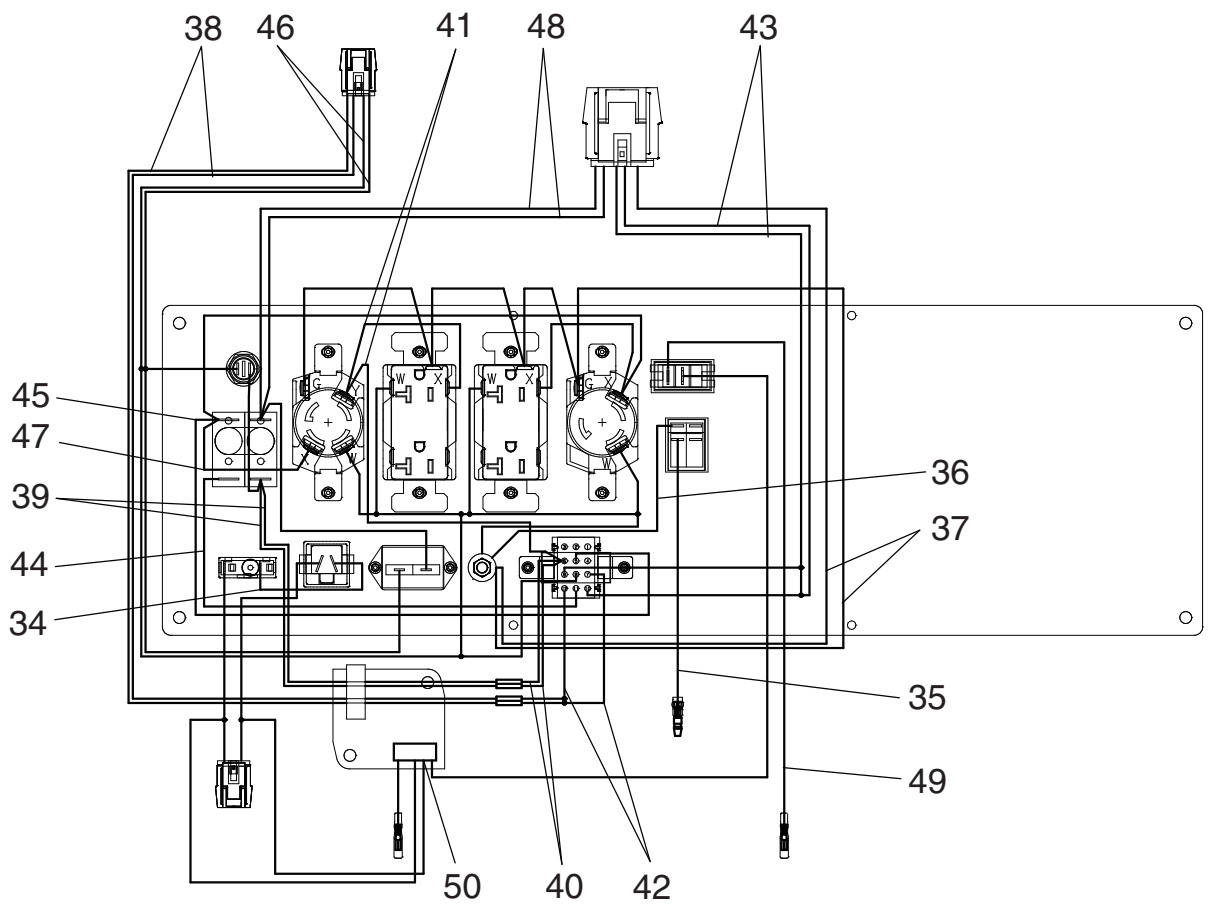
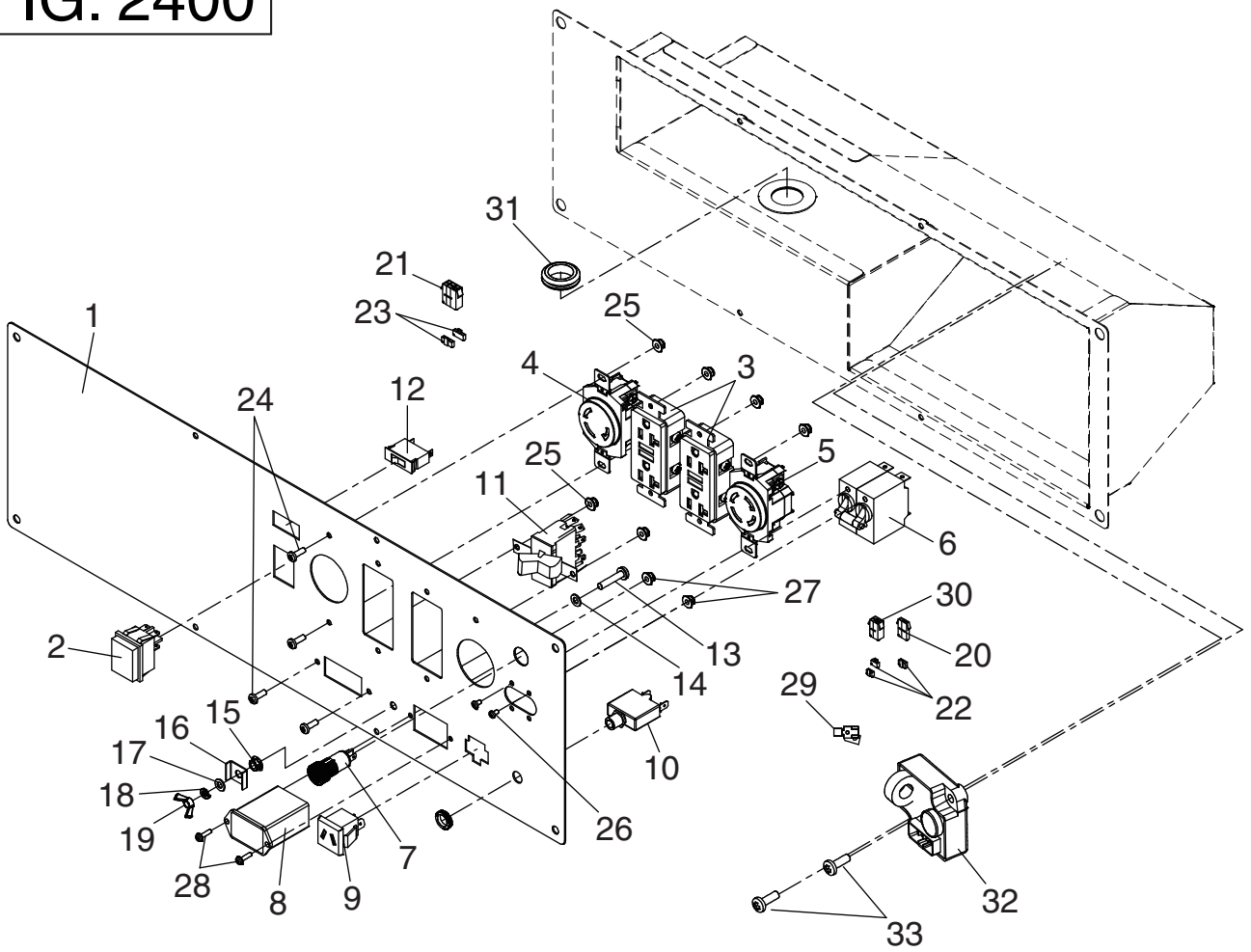

FIG. 2400



24 CONTROL

REF.	PART NUMBER	PART NAME	QTY	R E M A R K S	CODE NO.	INTERCHANGE P/NO.	UNIT P	FIG.
1	36C-41002-08	CONTROL PANEL CP	1					2400
2	36A-49000-08	SWITCH (ENGINE)	1					2400
3	36A-47002-08	AC CONCENT (GFCI)	2					2400
4	36B-47000-08	AC CONCENT (L5-30)	1					2400
5	36B-47001-08	AC CONCENT (L14-30)	1					2400
6	36C-48001-08	CIRCUIT BREAKER (20A)	1					2400
7	36A-49003-08	PILOT LAMP	1					2400
8	36A-49002-08	HOUR METER	1					2400
9	36A-47101-08	DC CONCENT	1					2400
10	36A-48001-08	CIRCUIT BREAKER (10A)	1					2400
11	36B-49000-08	SWITCH (V SELECT)	1					2400
12	36B-49001-08	SWITCH (I/C)	1					2400
13	36A-80102-08	SCREW & WASHER AY	1					2400
14	36A-82000-08	LOCK WASHER	1					2400
15	36A-81000-08	FLANGE NUT	1					2400
16	36A-82100-08	CAP WASHER	1					2400
17	36A-82200-08	WASHER	1					2400
18	36A-82300-08	SPRING WASHER	1					2400
19	36A-81100-08	WING NUT	1					2400
20	36A-70003-08	CONNECTOR (2P)	1					2400
21	36A-70001-08	CONNECTOR (6P)	1					2400
22	36A-70101-08	RETAINER (2P)	3					2400
23	36A-70100-08	RETAINER (3P)	2					2400
24	36A-80202-08	SCREW	10					2400
25	36A-81001-08	FLANGE NUT	10					2400
26	36A-80103-08	SCREW & WASHER AY	4					2400
27	36A-81005-08	FLANGE NUT	2					2400
28	36A-80203-08	SCREW	2					2400
29	36A-70300-08	TERMINAL	1					2400
30	36A-70007-08	CONNECTOR (4P)	1					2400
31	36C-49900-08	GROMMET	1					2400
32	KU3-11015-01	IDLE C/U CP (150V)	1					2400
33	36A-80204-08	SCREW	2					2400
34	36A-71003-08	WIRE (WHITE)	1					2400
35	36A-71006-08	WIRE (BLACK)	1					2400
36	36A-71036-08	WIRE (GREEN)	1					2400
37	36A-71037-08	WIRE (GREEN)	1					2400
38	36A-71029-08	WIRE (ORANGE)	2					2400
39	36A-71038-08	WIRE (RED)	1					2400
40	36A-71039-08	WIRE (RED)	1					2400
41	36A-71040-08	WIRE (RED)	1					2400
42	36A-71041-08	WIRE (ORANGE)	1					2400
43	36A-71042-08	WIRE (BLUE)	1					2400
44	36A-71043-08	WIRE (BLUE)	1					2400
45	36A-71044-08	WIRE (BLUE)	1					2400

FIG. 2400

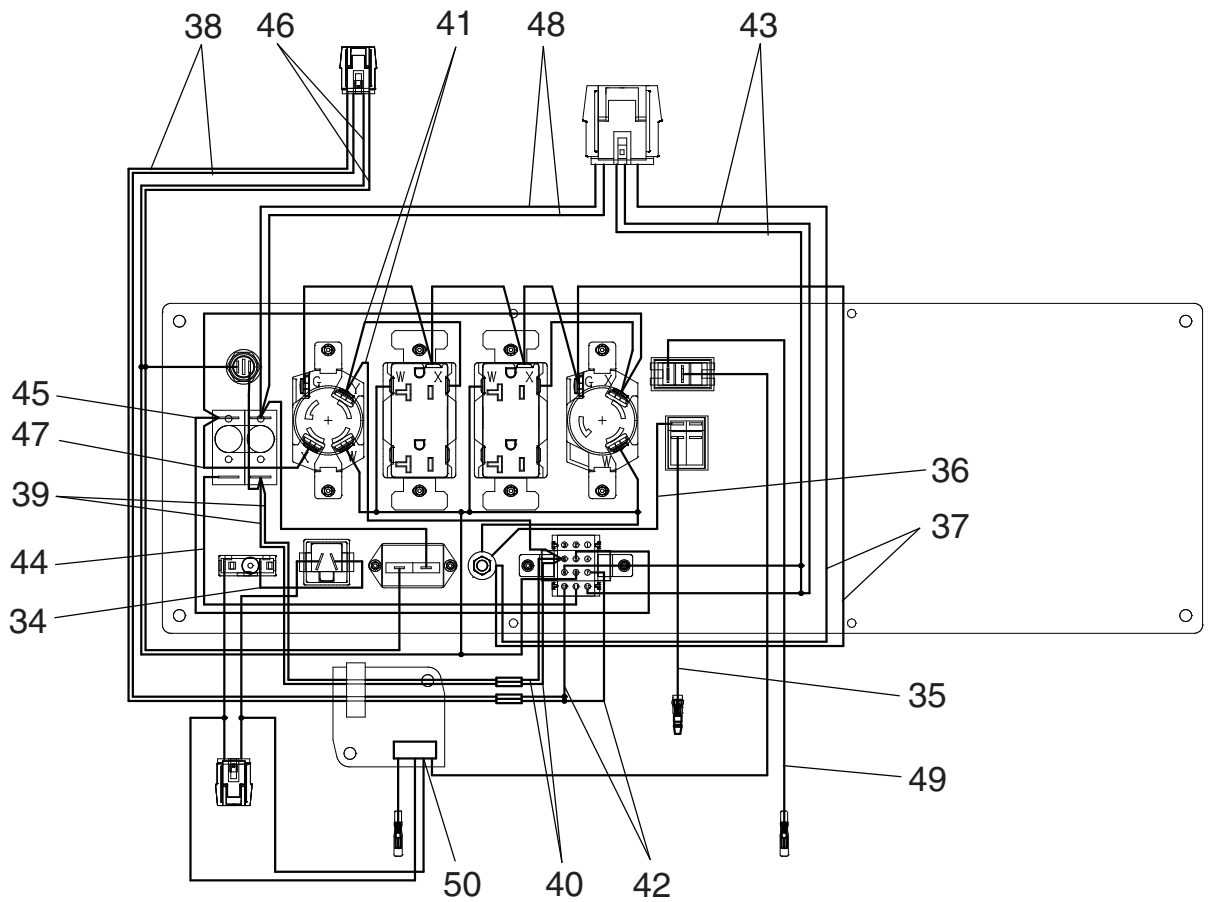
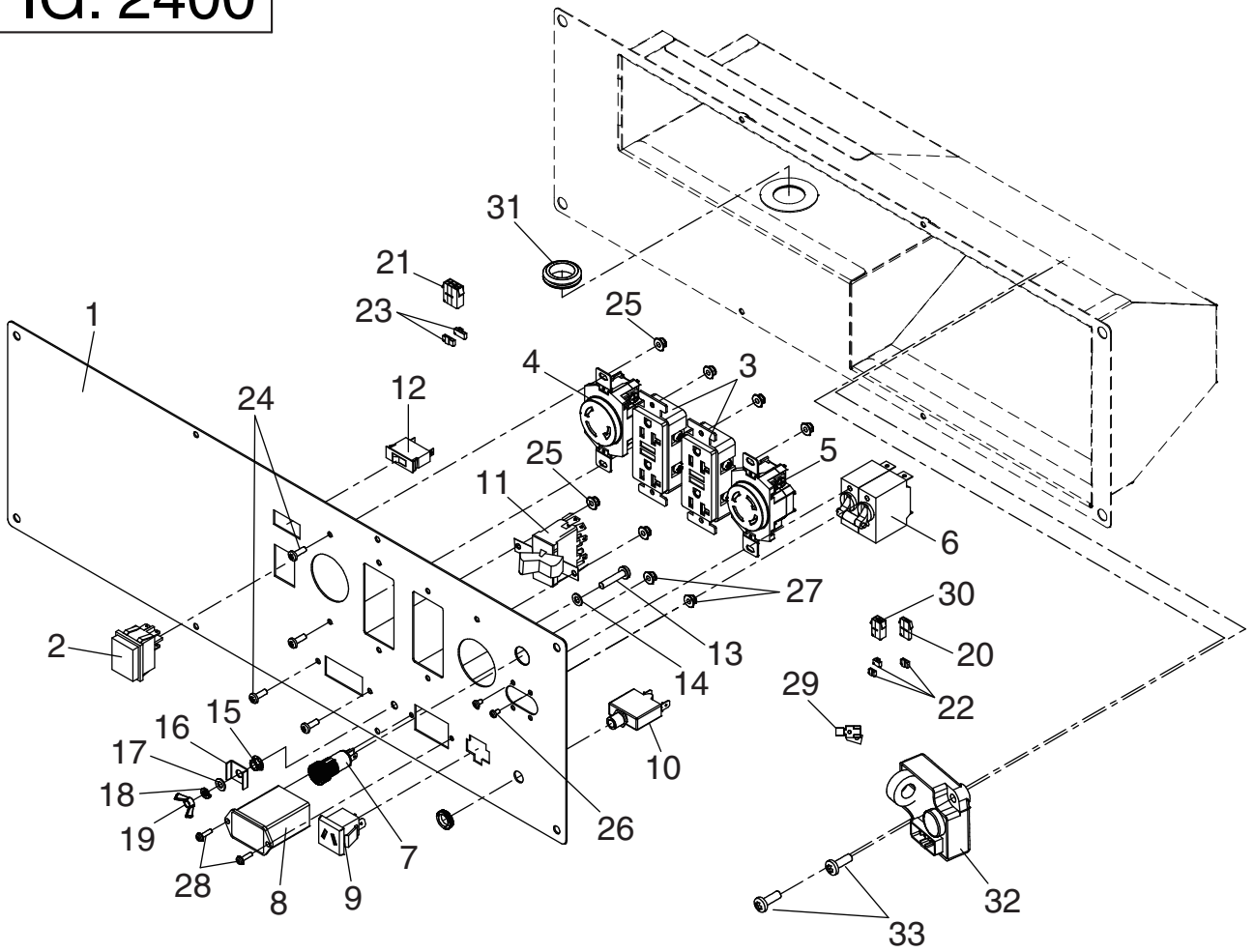

FIG. 2600

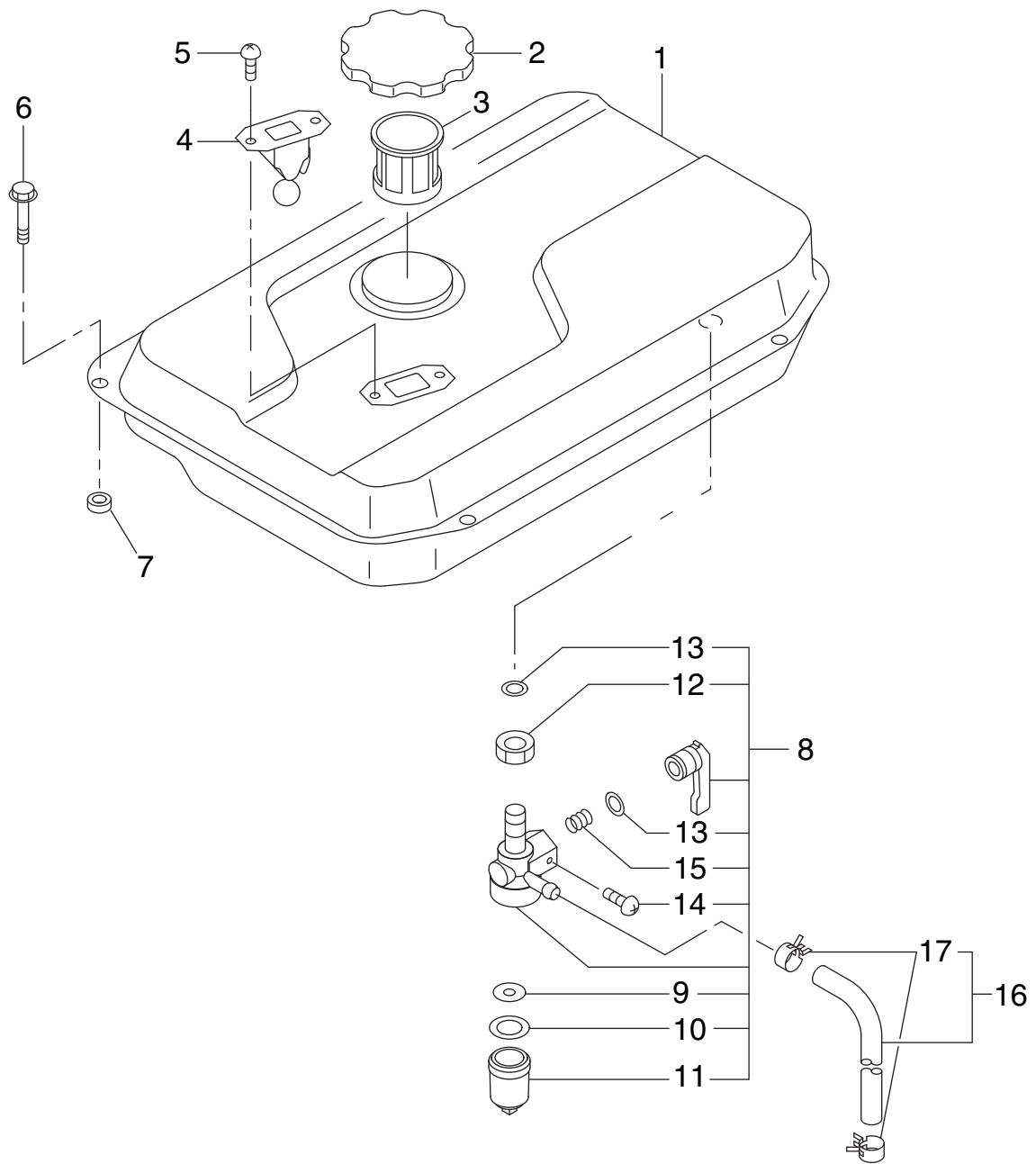

FIG. 2900

