

22 GENERATOR

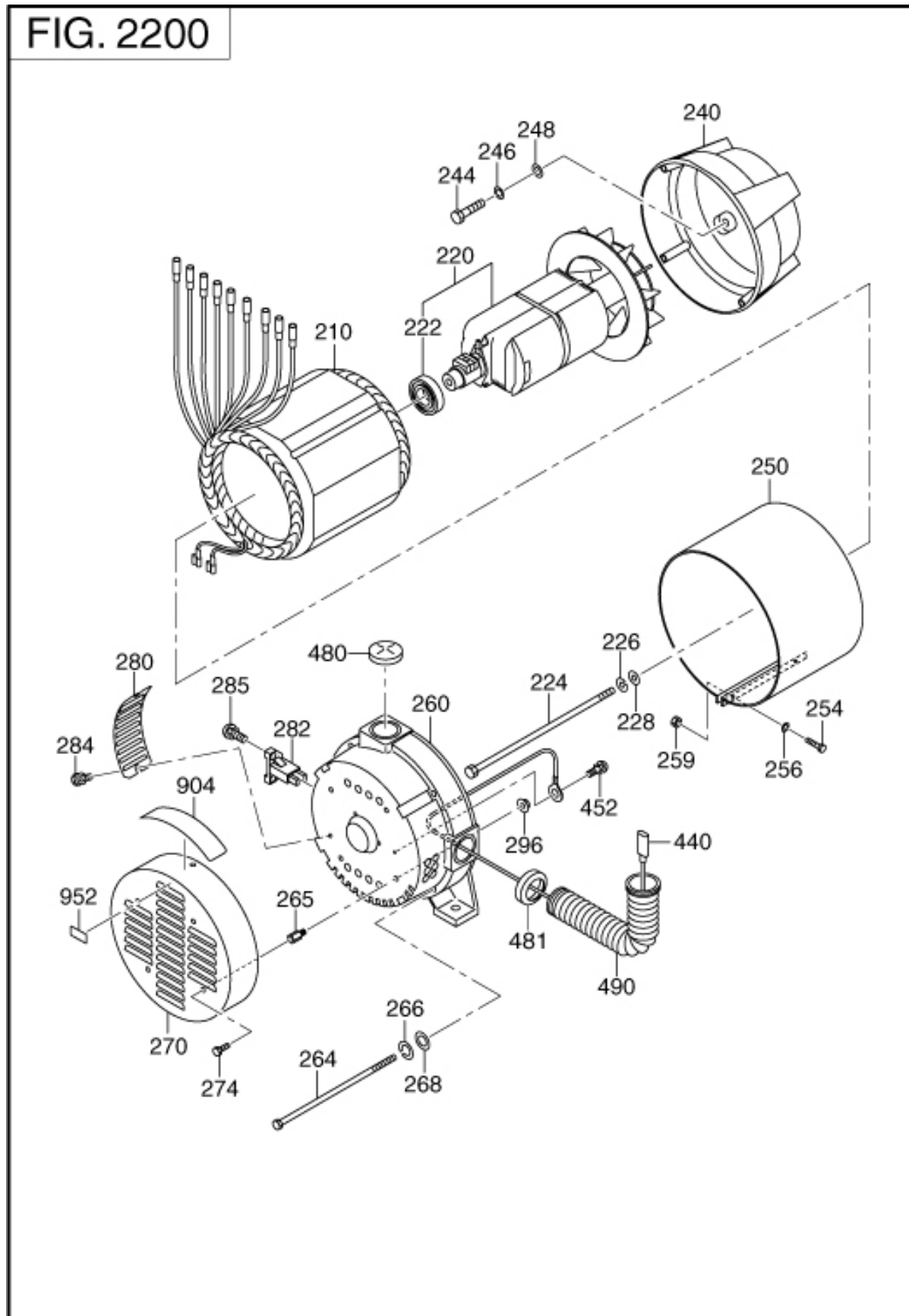

| REF. | PART NUMBER | PART NAME | CODE NO. | QTY | REMARKS | INTERCHANGE |
|------|--------------|-------------------|----------|-----|---------------------|--------------|
| 210 | 31F-52021-01 | STATOR CP | - | 1 | | |
| 220 | 31F-52018-01 | ROTOR CP | - | 1 | | |
| 222 | 354-58204-08 | BALL BEARING | - | 1 | | |
| 224 | 31F-54002-01 | THROUGH BOLT | - | 1 | | |
| 226 | 003-20080-00 | SPRING WASHER | - | 1 | 8. 2DX15. 4DX2T | |
| 228 | 003-10080-00 | WASHER | - | 1 | 8. 5DX16DX1. 2T | |
| 240 | 31F-53001-13 | FRONT BRACKET | - | 1 | | |
| 244 | 31F-54001-01 | BOLT | - | 4 | | |
| 246 | 003-20100-00 | SPRING WASHER | - | 4 | 10. 2DX18. 4DX2. 5T | |
| 248 | 003-10100-00 | WASHER | - | 4 | 10. 5DX18DX1. 6T | |
| 250 | 31F-54003-01 | STATOR COVER | - | 1 | | |
| 254 | 31F-54005-01 | BOLT | - | 2 | | |
| 256 | 003-20040-00 | SPRING WASHER | - | 2 | | |
| 259 | 002-17040-00 | NUT | - | 2 | | |
| 260 | 31F-53016-01 | REAR COVER | - | 1 | | |
| 264 | 365-58006-08 | THROUGH BOLT | - | 4 | | |
| 265 | 391-25600-03 | BOLT | - | 4 | | |
| 266 | 003-20080-00 | SPRING WASHER | - | 4 | 8. 2DX15. 4DX2T | |
| 268 | 003-10080-00 | WASHER | - | 4 | 8. 5DX16DX1. 2T | |
| 270 | 31F-54016-01 | END COVER | - | 1 | | |
| 274 | 011-00600-80 | FLANGE BOLT | - | 4 | M6X1. 0X14DX12L | |
| 280 | 31F-54004-01 | BRUSH COVER | - | 1 | | |
| 282 | 31G-74001-01 | BRUSH HOLDER CP | - | 1 | | 31H-54002-01 |
| 284 | 30A-71202-03 | SCREW & WASHER AY | - | 2 | | |
| 285 | 31G-62001-01 | SCREW & WASHER AY | - | 2 | | 013-10500-30 |
| 296 | 002-38060-00 | FLANGE NUT | - | 4 | M6X1. 0X13DX6H | |
| 440 | 31F-62017-01 | EARTH WIRE | - | 1 | | |
| 452 | 392-49986-08 | SCREW | - | 1 | M4X6L | |
| 490 | 353-57506-18 | BUSHING | - | 1 | | |
| 904 | 31F-81024-03 | LABEL, SPEC | - | 1 | | |