

22 GENERATOR

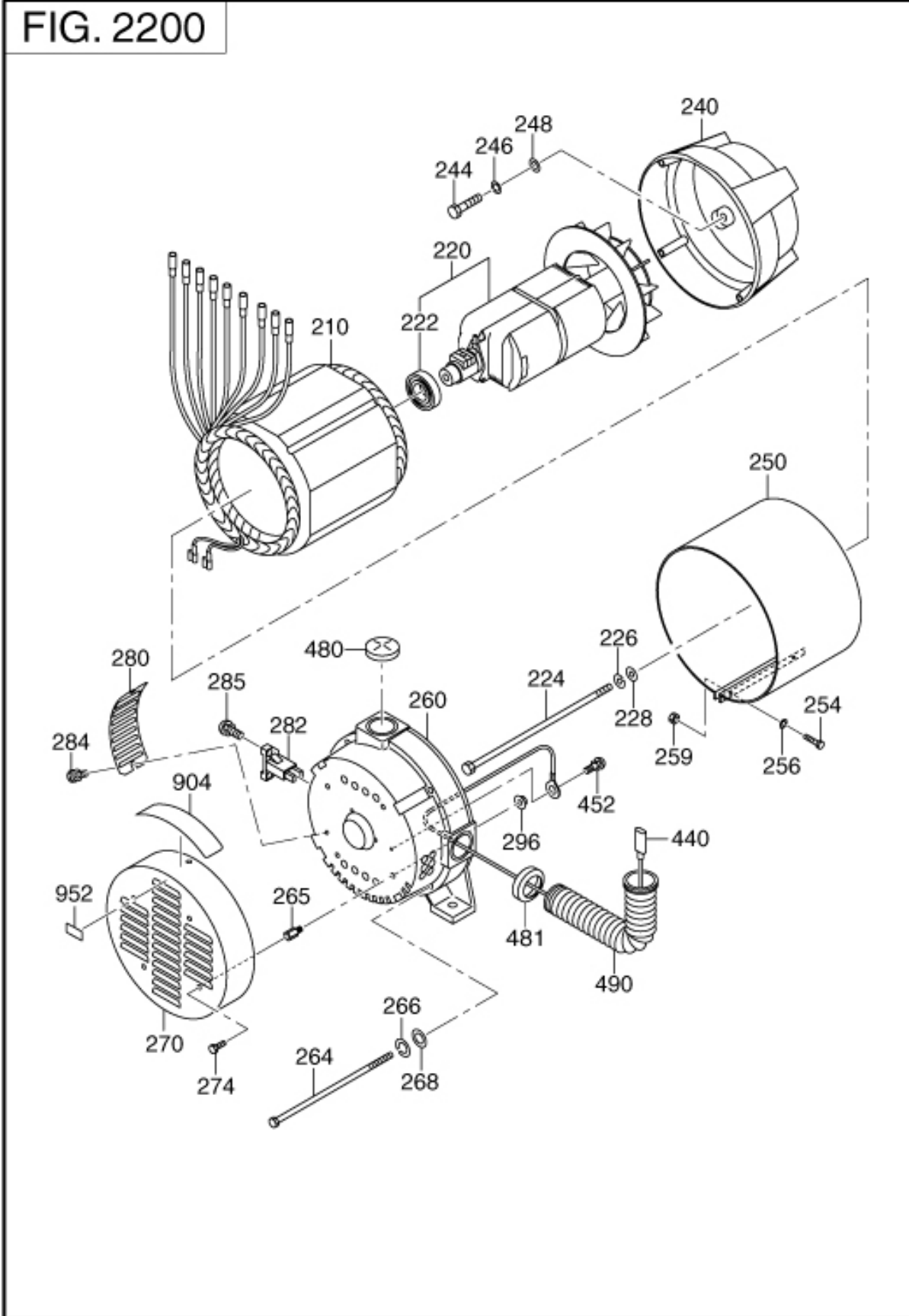

REF.	PART NUMBER	PART NAME	CODE NO.	QTY	REMARKS	INTERCHANGE
210	31F-52004-01	STATOR CP	-	1		
220	31F-52001-01	ROTOR CP	-	1		
222	354-58204-08	BALL BEARING	-	1		
224	31F-54002-01	THROUGH BOLT	-	1		
226	003-20080-00	SPRING WASHER	-	1	8. 2DX15. 4DX2T	
228	003-10080-00	WASHER	-	1	8. 5DX16DX1. 2T	
240	31F-53001-13	FRONT BRACKET	-	1		
244	31F-54001-01	BOLT	-	4		
246	003-20100-00	SPRING WASHER	-	4	10. 2DX18. 4DX2. 5T	
248	003-10100-00	WASHER	-	4	10. 5DX18DX1. 6T	
250	31F-54003-01	STATOR COVER	-	1		
254	31F-54005-01	BOLT	-	2		
256	003-20040-00	SPRING WASHER	-	2		
259	002-17040-00	NUT	-	2		
260	31F-53016-01	REAR COVER	-	1		
264	365-58006-08	THROUGH BOLT	-	4		
265	391-25600-03	BOLT	-	4		
266	003-20080-00	SPRING WASHER	-	4	8. 2DX15. 4DX2T	
268	003-10080-00	WASHER	-	4	8. 5DX16DX1. 2T	
270	31F-54016-01	END COVER	-	1		
274	35C-72014-03	FLANGE BOLT	-	4		
280	31F-54004-01	BRUSH COVER	-	1		
284	30A-71202-03	SCREW & WASHER AY	-	2		
296	002-38060-00	FLANGE NUT	-	4	M6X1. 0X13DX6H	
440	31F-62017-01	EARTH WIRE	-	1		
452	392-49986-08	SCREW	-	1	M4X6L	
490	353-57506-18	BUSHING	-	1		
904	31F-81060-13	LABEL(SPEC.)	-	1		
952	35A-82112-03	LABEL(ROTARY)	-	1		