



**ERSATZTEILLISTE**

**SPARE PARTS LIST**

**LISTE DES PIECES  
DE RECHANGE**

**LISTINO RICAMBI**

**LISTA DE RECAMBIOS**

**WYKAZ CZESCI  
ZAMIENNYCH**



**CR 8**

**011641-011643**



Weber Maschinentechnik GmbH  
Postfach 2153, 57329 Bad Laasphe-Rückershausen  
Telefon 02754 / 398-0  
Telefax (02754) 398-101 (Zentrale) u. 398-102 (Ersatzteile)

## EG - KONFORMITÄTSEKTLÄRUNG

EC DECLARATION OF CONFORMITY / DECLARATION DE CONFORMITE CE  
DICHIARAZIONE CE DI CONFORMITA / DECLARACION CE DE CONFORMIDAD  
EG-VERKLARING VAN OVEREENSTEMMING / EF-OVERENSSTEMMELSESEKTLÄRUNG  
DECLARACAO CE DE CONFORMIDADE / EG-FÖRSÄKRAN OM ÖVERENSSTÄMMELSE  
DEKLARACJA ZGODNOŚCI

### im Sinne der EG-Maschinenrichtlinie 98/37/EG und der EG Richtlinie 2000/14/EG - Geräuschemissionen

- I **Art / Category / Catégorie / Categoria Tipo / Kategori /**  
Soort / Categoria / kategori / Typ
- II **Hersteller (Typ) / Make (Type) / Marque (Type) / Marca (Tipo) /**  
Marca (Codice) / Producent (Type) / Merk (Type) / Marca (Tipo) /  
Tillverkare (Typ) / Producent
- III **Nennleistung / Nominal-performance / La puissance nominale / Prestazione nominale /**  
Potencia nominal / Nominaal vermogen / Nominel ydelse / Potência nominal / Nominell  
effect / Moc
- IV **gemessener Schalleistungspegel / measured sound power level / niveau de**  
puissance acoustique mesure / livello di potenza sonora rilevato / nivel de potencia  
acústica medido / gemeten geluidsvermogensniveau / målt lydeffektniveau / Nivel de  
potência sonora midido / uppmätt ljudeffektnivå / Mierzony poziom dźwięku
- V **garantierter Schalleistungspegel / guaranteed sound power level / niveau de**  
puissance acoustique garanti / livello di potenza sonora garantito / nivel de potencia  
acustica garantizado / gewaarborgd geluidsvermogensniveau / garanteret lydeffektniveau /  
Nivel sonoro garantido / garanterad ljudeffektnivå / Natężenie hałas
- VI **beteiligte Zertifizierungsstelle / notified body involved / de l'organisme notifié /**  
dell'organismo notificato che l'ha effettuata / dirección del organismo notificado que haya  
intervenido / betrokken aangemelde instantie / pagældende bemyndigede organ /  
organismo notificado involucrado / berörda anmälda organets namn / Jednostka  
certyfikująca
- VII **Konformitäts-Bewertungsverfahren / Conformity assessment procedure followed /**  
la procédure appliquée pour l'évaluation de la conformité et / procedura di valutazione  
della conformità / procedimiento de evaluación de la conformidad / gevolgdde  
overeenstemmingsbeoordelingsprocedure / den fulgte  
overensstemmelsesvurderingsprocedure / procedimento de avaliacao de conformidade  
/ Vilket förfarande för bedömning av överensstämmelse / Przebieg kontroli

Vibrationsplatte  
CR 8



P = 8,1 kW

LWA = 108 dB (A)

LWA = 109 dB (A)

RWTÜV  
Postfach 103161  
D-45032 Essen

interne Fertigungskontrolle  
nach Anhang VI  
EG Richtlinie 2000/14/EG

**ist in Übereinstimmung mit folgenden Richtlinien hergestellt worden / has been produced in accordance with following standards / est produit conforme aux dispositions des directives europeenes ci-apres / ha sido fabricado en conformidad con las siguientes normas / é stato fabbricato in conformità alle sequenti norme / er blevet fremstillet i overensstemmelse med følgende retningslinier / in overeenstemming met de volgende voorschriften gefabriceerd is / é fabricado conforme as seguintes normas / har tillverkats i överensstämmelse med följande riktlinjer / Zgodność z obowiązującymi przepisami**

**98/37/EG** Maschinenrichtlinie des europäischen Parlamentes und des Rates vom 22. Juni 1998  
**2000/14/EG** EG-Richtlinie Geräuschemissionen vom 8. Mai 2000  
**EN 500 Teil 1** Bewegliche Straßenbaumaschinen – Sicherheit  
Gemeinsame Anforderungen  
**EN 500 Teil 4** Bewegliche Straßenbaumaschinen – Sicherheit  
Besondere Anforderungen an Verdichtungsmaschinen

**Bescheinigung bitte sorgfältig aufbewahren / File certificate carefully / Conserver certificat soigneusement / Conservar certificado cuidadosamente / Pregasi conservare accuratamente certificato / Beviset bedes opbevares omhyggeligt / Verklaring a.u.b. zorgvuldig bevar / Conservar o certificado com cuidado / Beviset skall om sorgfullt bevaras // Deklarację zgodności proszę zachować**

Bad Laasphe – Rückershausen, den **02.01.2004**

  
W. Weber, Geschäftsführer

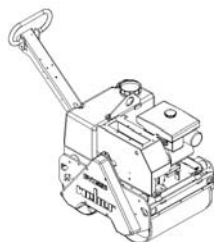

**WEBER Maschinentechnik GmbH**  
Im Boden 5-8, 10 – D-57334 Bad Laasphe  
Postfach 2153 – D-57329 Bad Laasphe  
Telefon: 02754/398-0 – Fax 02754/398-101  
E-mail: [Verkauf@webermt.de](mailto:Verkauf@webermt.de)  
Internet: <http://www.webermt.de>



BITTE, NOTIEREN SIE SERIENNUMMER UND MOTORNUMMER IHRER MASCHINE:

PLEASE WRITE DOWN SERIALNUMBERS OF MACHINE AND ENGINE:

NOTEZ SVP LE NUMERO DE SERIE ET LE NUMERO DU MOTEUR DE VOTRE MACHINE:

SI PREGA DI ANNOTARE SEMPRE I NUMERI DI SERIE SIA DELLA VS. MACCHINA CHE DEL MOTORE:

MAQUINA: ROGAMOS ANOTEN EL NUMERO DE SERIE Y NUMERO DE MOTOR DE SU MAQUINA:

MASCHINE  
MACHINE  
MACCHINA  
MAQUINA

MOTOR  
ENGINE  
MOTEUR  
MOTORE

ZUR VERMEIDUNG VON FEHLLIEFERUNGEN UND VERZÖGERUNGEN SIND BEI DER BESTELLUNG VON ERSATZTEILEN FOLGENDE ANGABEN UNBEDINGT ERFORDERLICH:

- MASCHINENTYP
- SERIENNUMMER DER MASCHINE
- SERIENNUMMER DES MOTORS (BEI MOTORTEILEN)
- TEILENUMMER
- BESTELLMENGE

TO AVOID ERRORS IN DELIVERY PLEASE STATE THESE PARTICULARS WHEN ORDERING:

- TYPE OF MACHINE
- SERIAL NO. OF MACHINE
- SERIAL NO. OF ENGINE (ON ENGINE PARTS)
- PART-NO.
- QUANTITY REQUIRED

AFIN D'EVITER DES ERREURS DE COMMANDE ET DES RETARDS DE LIVRAISON IL EST NECESSAIRE D'INDIQUER LES CARACTERISTIQUES SUIVANTES:

- TYPE DE MACHINE
- LE NUMERO DE SERIE DE LA MACHINE
- LE NUMERO DE SERIE DU MOTEUR
- LE NUMERO D'IDENTITE DE LA PIECE
- LA QUANTITE SOUHAITEE

ONDE EVITARE DISGUIDI E RITARDI NELLE CONSEGNE DIE RICAMBI SI PREGA DI INDICARE SEMPRE:

- TIPO DELLA MACCHINA
- NUMERO DI SERIE DELLA MACCHINA
- NUMERO DI SERIE DEL MOTORE (SE SI RICHIEDONO PEZZI DEL MOTORE)
- NUMERO D'ORDINE DIE SINGOLI RICAMBI
- QUANTITA

A FI DE EVITAR ERRORES DE ENTREGA, ROGAMOS INDIQUEN LOS SIGUIENTES DATOS CUANDO PASE PEDIDOS DE RECAMBIO:

- MODELO DE MAQUINA
- NO. DE SERIE DE LA MAQUINA
- NO. DE SERIE DEL MOTOR (EN PIEZAS PARA MOTOR)
- REFERENCIA DEL RECAMBIO
- CANTIDAD PEDIDA

## E 3000-1001

Position Ref.No. Repère Posizione Posicion	Menge Quantity Quantité Quantita Cantidad	Teile-Nr. Part-No. No. Référence Nr. d'Ordine No. Referenzia	Hinweis Hints Indications Indicazione Indicaciones	Position Ref. No. Repère Posizione Posicion	Menge Quantity Quantité Quantita Cantidad	Teile-Nr. Part-No. No. Référence Nr. d'Ordine No. Referenzia	Hinweis Hints Indications Indicazione Indicaciones
1	1	10016160					
2	8	20026485					
3	1	25030002	DIN908-M14x1,5				
4	2	10016161					
5	6	20029009	VSK 20				
6	6	25038027	DIN933-M20x50				
7	2	10016162					
8	2	10016163					
9	12	20025158					
10	12	25038021	DIN933-M12x35				
11	4	20004012					
12	8	25049019	DIN7349-17x40x6				
13	8	20029002	VSK 16				
14	4	25031006	DIN934-M16				
15	4	25025009					
16	4	10016367					
17	4	10001423					
18	4	20025158					
19	4	20005018					
20	1	20013289					
21	1	20013288					
22	1	20013287					
23	6	20029011	VSKZ 8				
24	6	25044007	DIN912-M8x30				
25	1	10001444					
26	8	20029026					
27	6	25045041	DIN912-M12x140				
28	2	25045042	DIN912-M12x170				

Hatz

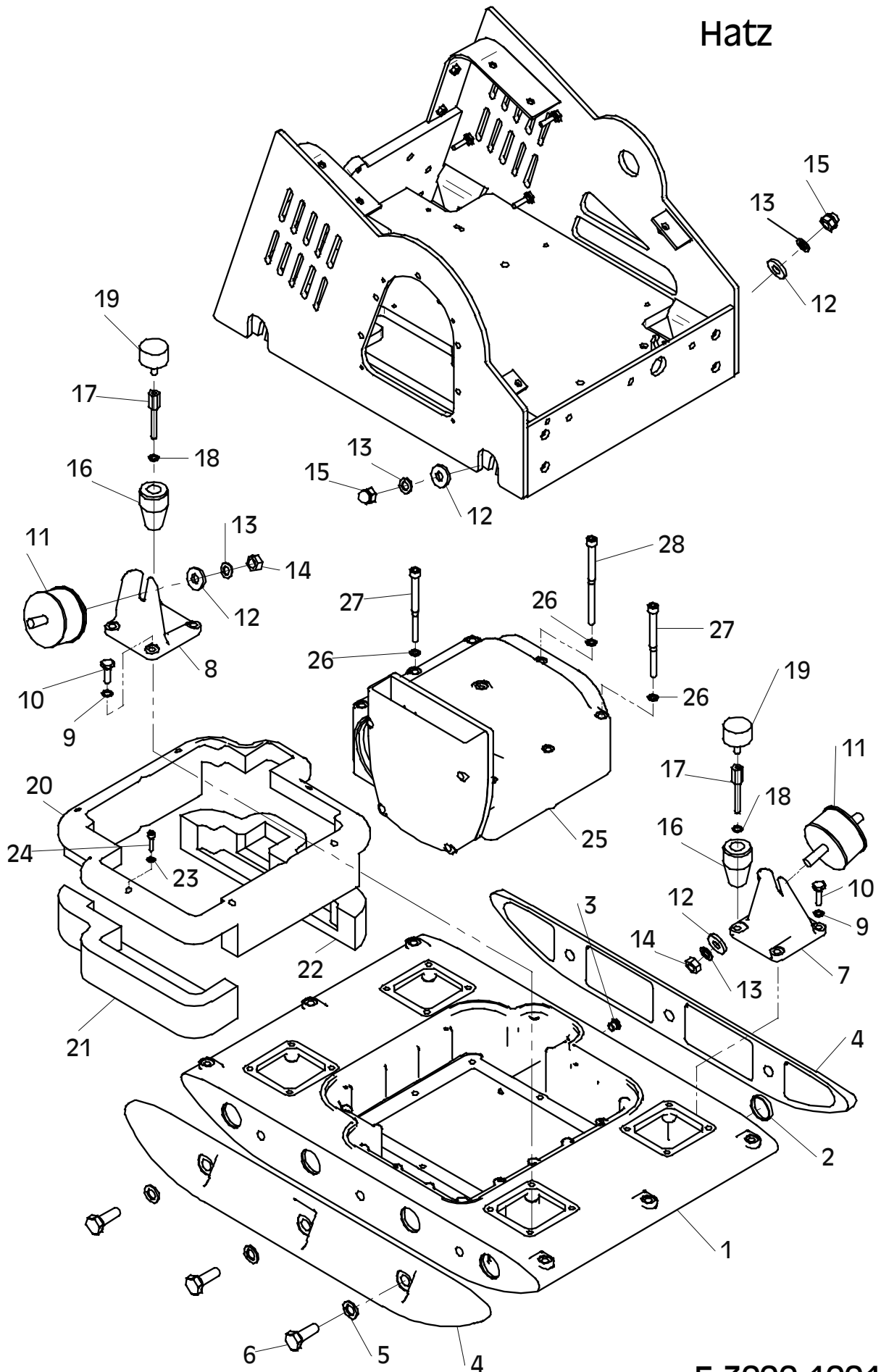

E 3000-1001

## E 3177-0904

Position Ref.No. Repère Posizione Posicion	Menge Quantity Quantité Quantita Cantidad	Teile-Nr. Part-No. No. Référence Nr. d'Ordine No. Referenzia	Hinweis Hints Indications Indicazione Indicaciones	Position Ref. No. Repère Posizione Posicion	Menge Quantity Quantité Quantita Cantidad	Teile-Nr. Part-No. No. Référence Nr. d'Ordine No. Referenzia	Hinweis Hints Indications Indicazione Indicaciones
1	1	10016160		30	2	20025158	
2	8	20026485		31	2	25044047	DIN912-M12x50
3	1	25030002	DIN908-M14x1,5	32	2	10017304	
4	2	10016161		33	2	10017300	
5	6	20029009	VSK 20	34	2	20026576	
6	6	25038027	DIN933-M20x50				
7	2	10016162					
8	2	10016163					
9	12	20025158					
10	12	25038021	DIN933-M12x35				
11	4	20004012					
12	8	25049019	DIN7349-17x40x6				
13	8	20029002	VSK 16				
14	4	25031006	DIN934-M16				
15	4	25025009					
16	2	10016367					
17	2	10001423					
18	2	20025158					
19	2	20005018					
20	1	20013289					
21	1	20013288					
22	1	20013287					
23	6	20029011	VSKZ 8				
24	6	25044007	DIN912-M8x30				
25	1	10001444	<b>CR 8 CCD</b>				
25	1	10001465	<b>CR 8 Hd CCd</b>				
26	8	20029026					
27	6	25045041	DIN912-M12x140				
28	2	25045042	DIN912-M12x170				
29	2	10017299					

Hatz-CCD  
Honda-CCD

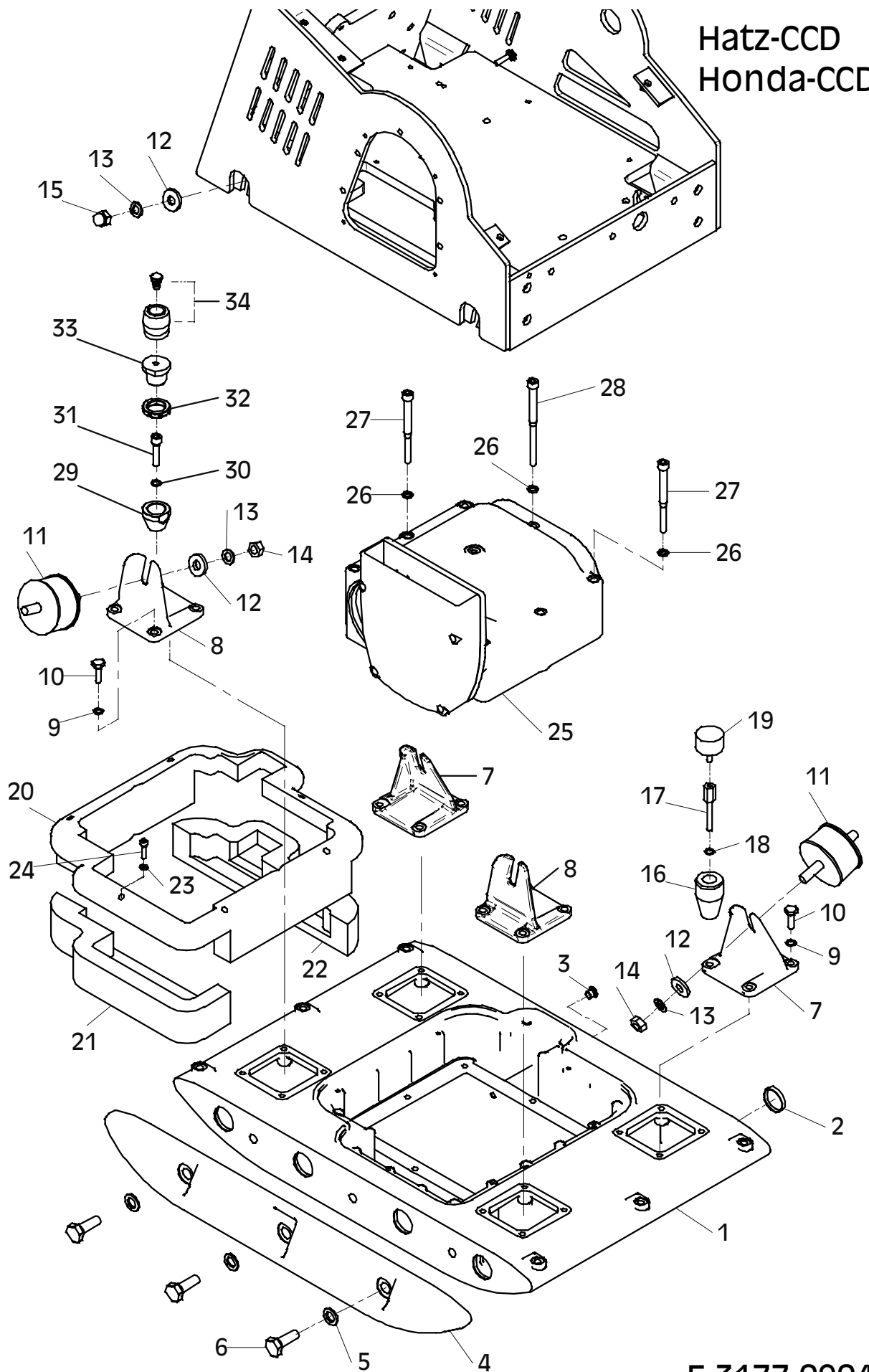

E 3177-0904

## E 3001-0904

Position Ref.No. Repère Posizione Posicion	Menge Quantity Quantité Quantita Cantidad	Teile-Nr. Part-No. No. Référence Nr. d'Ordine No. Referenzia	Hinweis Hints Indications Indicazione Indicaciones	Position Ref. No. Repère Posizione Posicion	Menge Quantity Quantité Quantita Cantidad	Teile-Nr. Part-No. No. Référence Nr. d'Ordine No. Referenzia	Hinweis Hints Indications Indicazione Indicaciones
1	1	10016164		29	1	10017035	<b>Honda</b>
2	1	25038042	DIN933-M12x16	30	1	10016388	
3	1	25008011	DIN7603-12x18x1,5	31	1	10007370	
4	1	10016165		32	1	20029001	VSK 10
5	4	25044010	DIN912-M8x65	33	1	10016382	
6	4	20029011	VSKZ 8	34	2	25001701	
7	2	10016167		35	1	10016826	
8	8	25044005	DIN912-M8x20	36	2	25025157	
9	8	20029011	VSKZ 8	37	2	25045035	DIN912-M12x50
10	2	20013290		38	1	10016386	
11	1	10016166		39	2	25001702	
12	4	25044005	DIN912-M8x20	40	1	10016171	
13	4	20029011	VSKZ 8	41	1	10016383	
14	1	25017201		42	1	10016385	
15	1	20013290		43	1	25029015	
16	1	10016168		44	1	25028004	DIN915-M10x25
17	4	25044005	DIN912-M8x20	45	1	25035018	DIN472-I32
18	4	20029011	VSKZ 8	46	1	25001703	
19	1	25030016	DIN910-M10x1	47	1	25034025	DIN471-A15x1
20	1	25008012	DIN7603-10x16x1	48	1	10016387	
21	1	20013290		49	1	20013275	
22	1	10016379		50	1	25030001	DIN908-M10x1
23	2	25001701		51	1	20020562	
24	1	10016170		52	0	25026027	
25	1	25015076		53	0	25026028	
26	2	10016827		54	0	25026029	
27	2	25025157		55	1	20013305	
28	2	25045035	DIN912-M12x50				
29	1	10016828	<b>Hatz</b>				

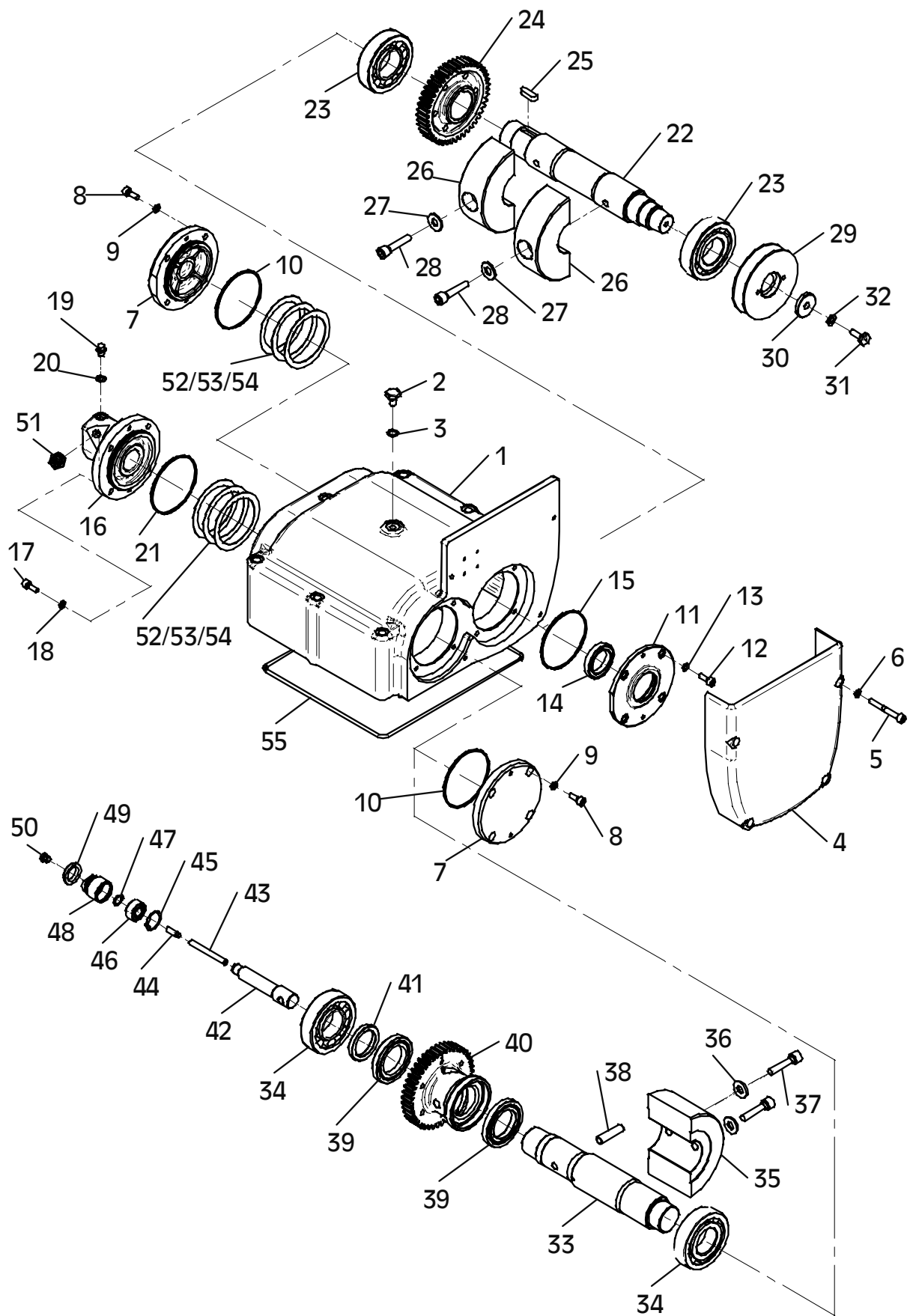

E 3001-0904

## E 3002-0304

Position Ref.No. Repère Posizione Posicion	Menge Quantity Quantité Quantità Cantidad	Teile-Nr. Part-No. No. Référence Nr. d'Ordine No. Referenzia	Hinweis Hints Indications Indicazione Indicaciones	Position Ref. No. Repère Posizione Posicion	Menge Quantity Quantité Quantità Cantidad	Teile-Nr. Part-No. No. Référence Nr. d'Ordine No. Referenzia	Hinweis Hints Indications Indicazione Indicaciones
1	1	10022518		30	4	20029001	VSK 10
2	1	10016293		31	4	25031004	DIN934-M10
3	5	25038014	DIN933-M10x25	32	1	10022651	
4	5	25049035	VSF 10	33	9	25038014	DIN933-M10x25
5	1	10016301		34	9	25049035	VSF 10
6	4	25038006	DIN933-M8x16	37	1	25044037	DIN912-M10x55
7	4	20029003	VSK 8	38	2	25048003	DIN125-A10,5
8	4	25048002	DIN125-A8,4	40	1	25031014	DIN985-M10
9	1	20005006		41	1	20026481	
10	1	25049029	DIN1052-14x58x6	42	2	25025191	DIN80705-M20x1,5
11	1	20029004	VSK 12	43	2	20025019	
12	1	25038022	DIN933-M12x40	49	1	10022650	
13	1	10016292		50	8	25044045	DIN912-M16x40
14	2	20029022	SKB 10	51	8	20029029	
15	2	25038013	DIN933-M10x20	52	4	20026565	
16	1	10022536		53	2	20026497	
17	6	25044002	DIN912-M6x16	54	2	20026496	
18	6	20022001	Tensilock M6	55	1	10016453	
19	1	10016394		56	1	10016454	
20	1	10016415		57	2	20026495	
21	8	10016365		58	2	20026494	
22	1	10022541					
23	4	20029001	VSK 10				
24	4	25031004	DIN934-M10				
25	1	10016365					
26	1	20007077					
27	1	20029003	VSK 8				
28	1	25040065	DIN931-M8x40				
29	1	10016399					

Hatz

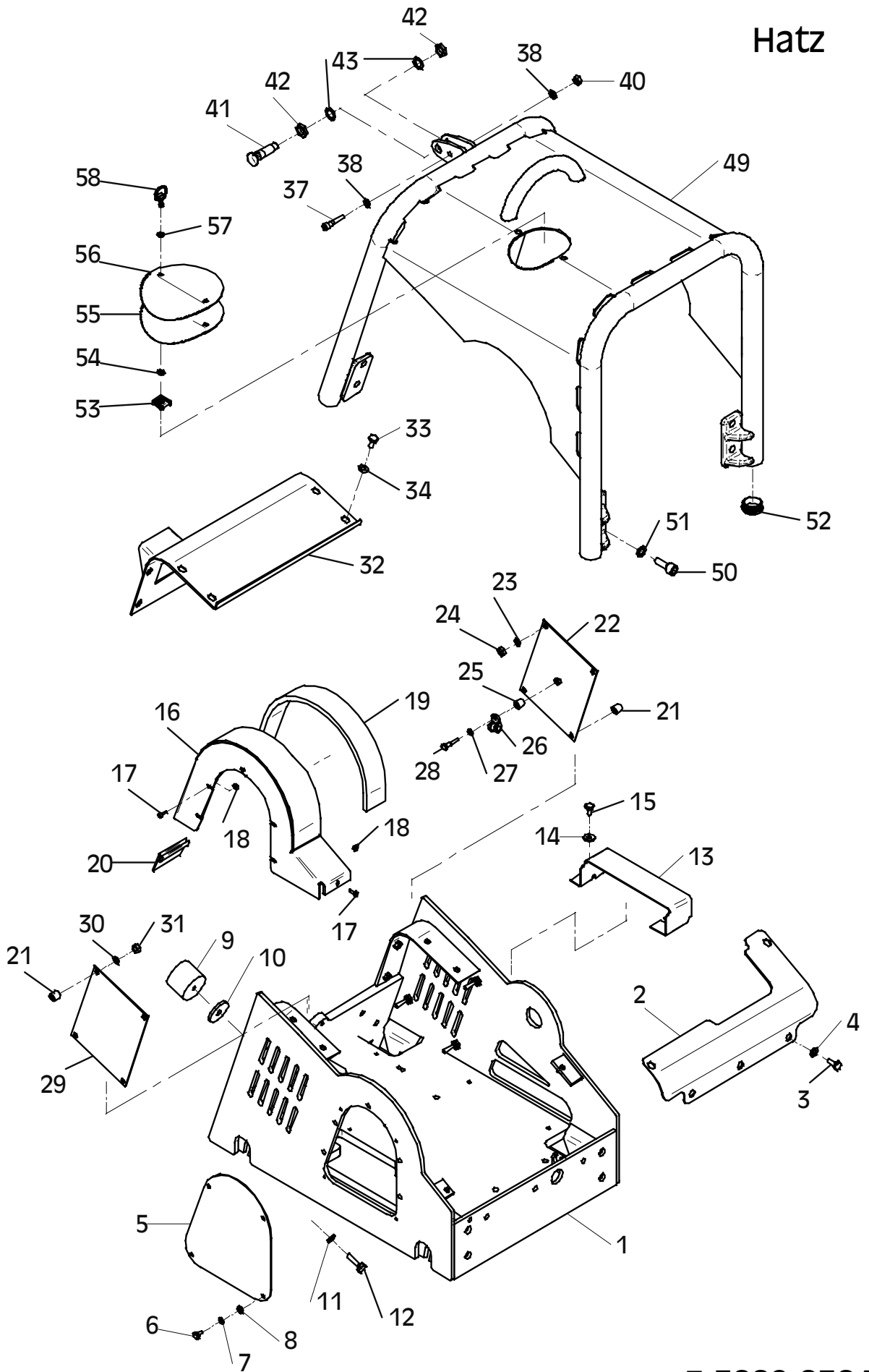

E 3002-0304

## E 3135-0904

Position Ref.No. Repère Posizione Posicion	Menge Quantity Quantité Quantita Cantidad	Teile-Nr. Part-No. No. Référence Nr. d'Ordine No. Referenzia	Hinweis Hints Indications Indicazione Indicaciones	Position Ref. No. Repère Posizione Posicion	Menge Quantity Quantité Quantita Cantidad	Teile-Nr. Part-No. No. Référence Nr. d'Ordine No. Referenzia	Hinweis Hints Indications Indicazione Indicaciones
1	1	10022518		44	2	20007226	
2	1	10016293		45	1	25038003	DIN933-M6x20
3	5	25038014	DIN933-M10x25	46	1	25048001	DIN125-B6,4
4	5	25049035	VSF 10	47	1	20029007	VSK 6
5	1	10016301		48	1	25031002	DIN934-M6
6	4	25038006	DIN933-M8x16	49	1	10022650	
7	4	20029003	VSK 8	50	8	25044045	DIN912-M16x40
8	4	25048002	DIN125-A8,4	51	8	20029029	
9	1	20005006		52	4	20026565	
10	1	25049029	DIN1052-14x58x6	53	2	20026497	
11	1	20029004	VSK 12	54	2	20026496	
12	1	25038022	DIN933-M12x40	55	1	10016453	
13	1	10016292		56	1	10016454	
14	2	20029022	SKB 10	57	2	20026495	
15	2	25038013	DIN933-M10x20	58	2	20026494	
16	1	10022536		59	1	10017320	
17	6	25044002	DIN912-M6x16	60	2	25033030	ISO7380-M6x20
18	6	20022001	Tensilock M6	61	2	25049033	DIN9021-6,4/18x1,6
19	1	10016394		62	2	20022001	Tensilock M6
20	1	10016415		63	1	20026544	
21	8	10016365		64	1	20026545	
22	1	10022541		65	1	25046021	DIN6912-M8x35
23	4	20029001	VSK 10	66	3	25049013	DIN440-R11,5
24	4	25031004	DIN934-M10	67	1	20022002	Tensilock M8
25	1	10016365					
26	1	20007077					
27	1	20029003	VSK 8				
28	1	25040065	DIN931-M8x40				
29	1	10016399					
30	4	20029001	VSK 10				
31	4	25031004	DIN934-M10				
32	1	10022648					
33	9	25038014	DIN933-M10x25				
34	9	25049035	VSF 10				
37	1	25044037	DIN912-M10x55				
38	2	25048003	DIN125-A10,5				
40	1	25031014	DIN985-M10				
41	1	20026481					
42	2	25025191	DIN80705-M20x1,5				
43	2	20025019					

# Hatz-CCD

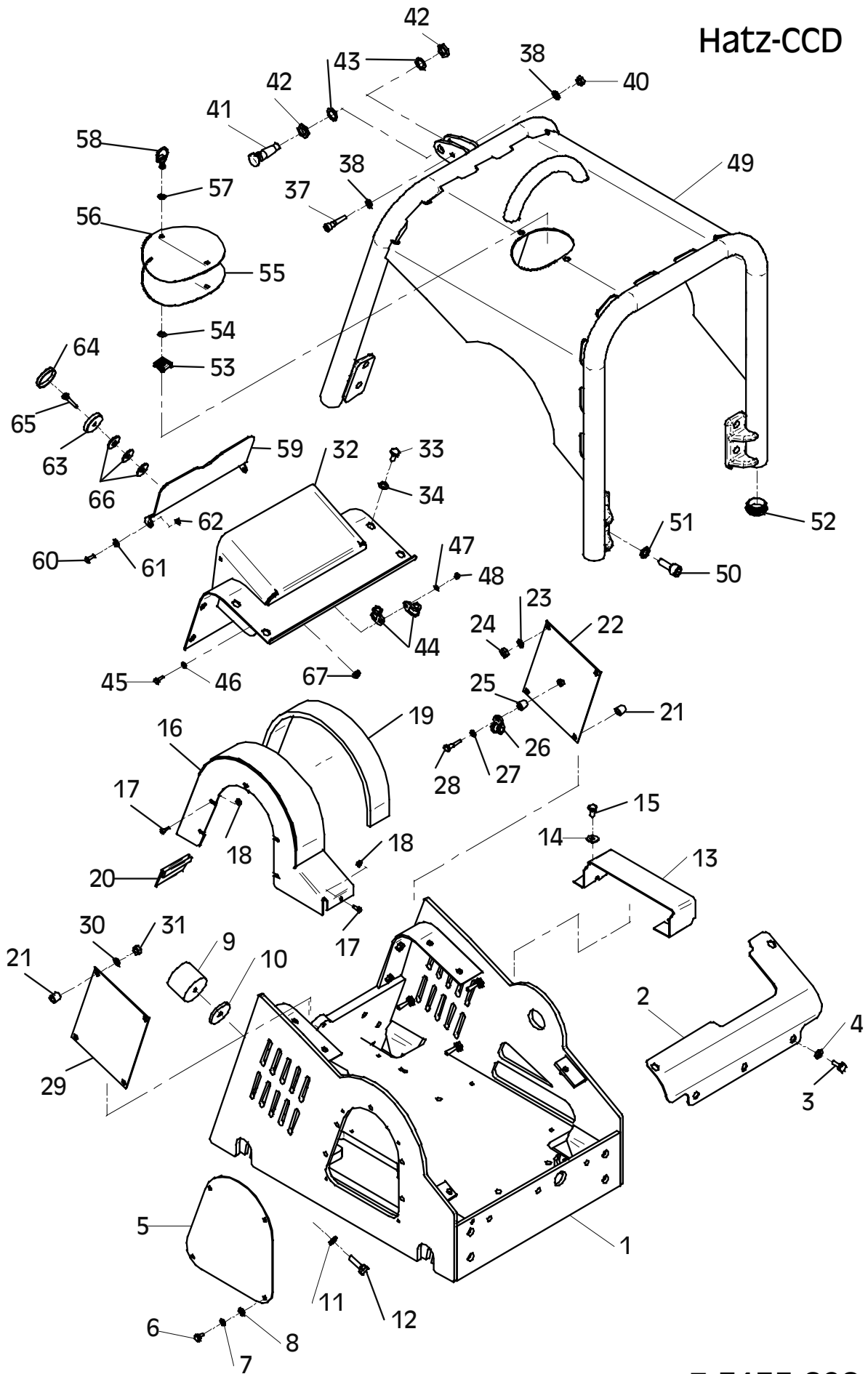

E 3135-0904

## E 3003-1001

Position Ref.No. Repère Posizione Posicion	Menge Quantity Quantité Quantita Cantidad	Teile-Nr. Part-No. No. Référence Nr. d'Ordine No. Referenzia	Hinweis Hints Indications Indicazione Indicaciones	Position Ref. No. Repère Posizione Posicion	Menge Quantity Quantité Quantita Cantidad	Teile-Nr. Part-No. No. Référence Nr. d'Ordine No. Referenzia	Hinweis Hints Indications Indicazione Indicaciones
1	1	20001233		31	1	25044003	DIN912-M6x20
2	2	25041065	DIN931-M12x100	32	1	25031002	DIN934-M6
3	1	25044066	DIN912-M12x90	33	1	25049034	DIN7349-6,4
4	1	20025158		34	1	20022001	Tensilock M6
5	1	25040079	DIN931-M12x110	35	1	10016365	
6	3	20029023	SKB 12	36	1	25033026	DIN444-M10x60
7	4	20029026		37	1	20029001	VSK 10
8	4	25031005	DIN934-M12	38	1	25044017	DIN912-M10x65
9	2	25048004	DIN125-A13	39	1	25031024	DIN936-M10
10	1	25031005	DIN934-M12	40	2	25048010	DIN1440-11x25x3
11	1	10016368		41	1	25031004	DIN934-M10
12	4	20029011	VSKZ 8	42	1	20007228	
13	4	25044006	DIN912-M8x25	43	1	20025047	
14	1	20002082		44	1	20025060	
15	1	25002175		45	1	20025271	
16	1	25049011	DIN7349-13x30x6	46	1	20007077	
17	1	20029004	VSK 12	47	1	25048003	DIN125-A10,5
18	1	25040033	DIN931-M12x70	48	1	25038015	DIN933-M10x30
19	1	10017285					
20	3	20029012	VSKZ 10				
21	3	25044041	DIN912-M10x20				
22	1	10022538					
23	3	20029012	VSKZ 10				
24	3	25044041	DIN912-M10x20				
25	1	20025590					
26	1	10022516					
27	4	20029020	SKB 6				
28	4	25044003	DIN912-M6x20				
29	2	20025485					
30	1	20007007					

# Hatz / Hatz-CCD

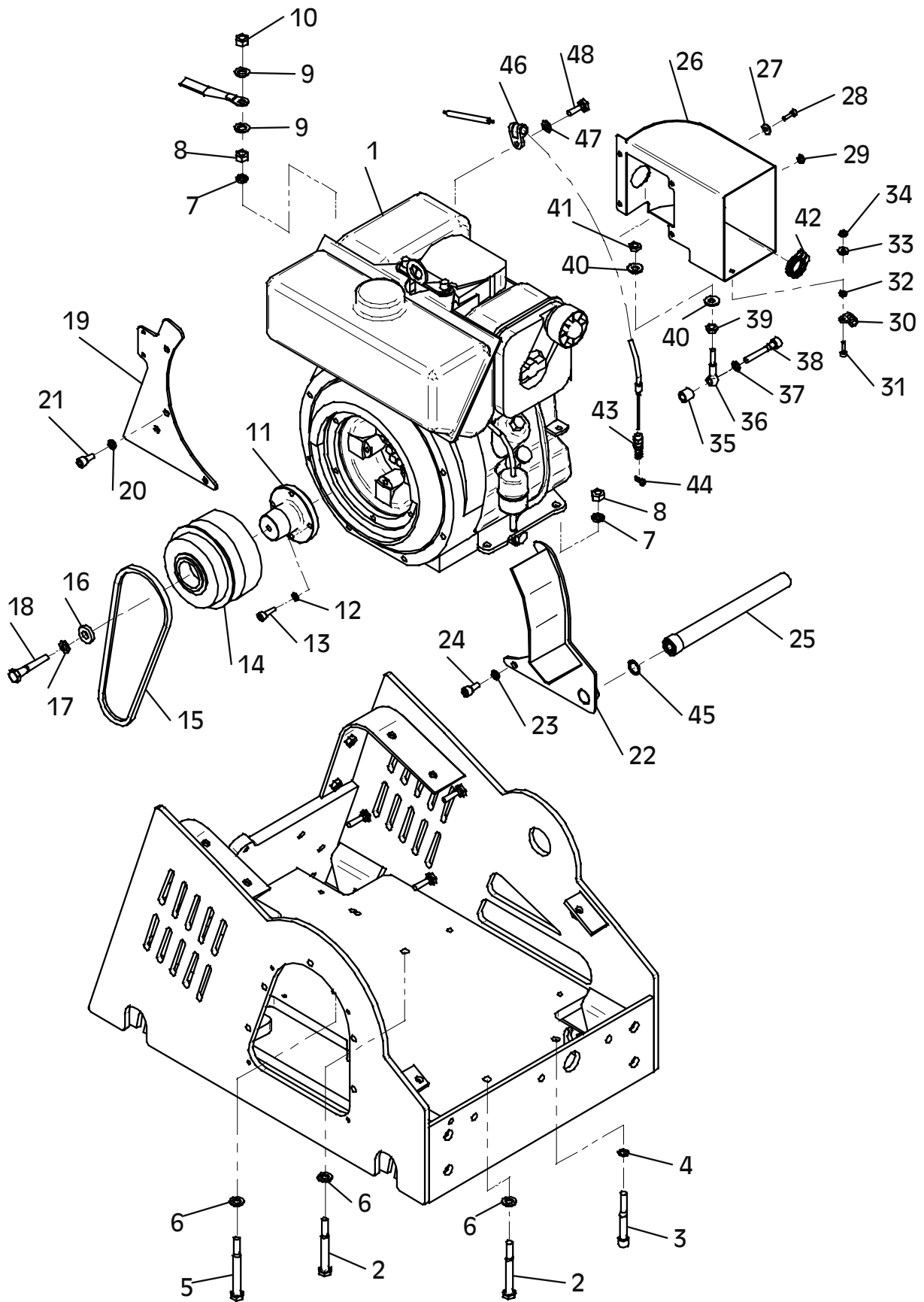

## E 3004-0202

Position Ref.No. Repère Posizione Posicion	Menge Quantity Quantité Quantita Cantidad	Teile-Nr. Part-No. No. Référence Nr. d'Ordine No. Referenzia	Hinweis Hints Indications Indicazione Indicaciones	Position Ref. No. Repère Posizione Posicion	Menge Quantity Quantité Quantita Cantidad	Teile-Nr. Part-No. No. Référence Nr. d'Ordine No. Referenzia	Hinweis Hints Indications Indicazione Indicaciones
1	1	20002082					
2	2	20002268					
3	2	20002330					

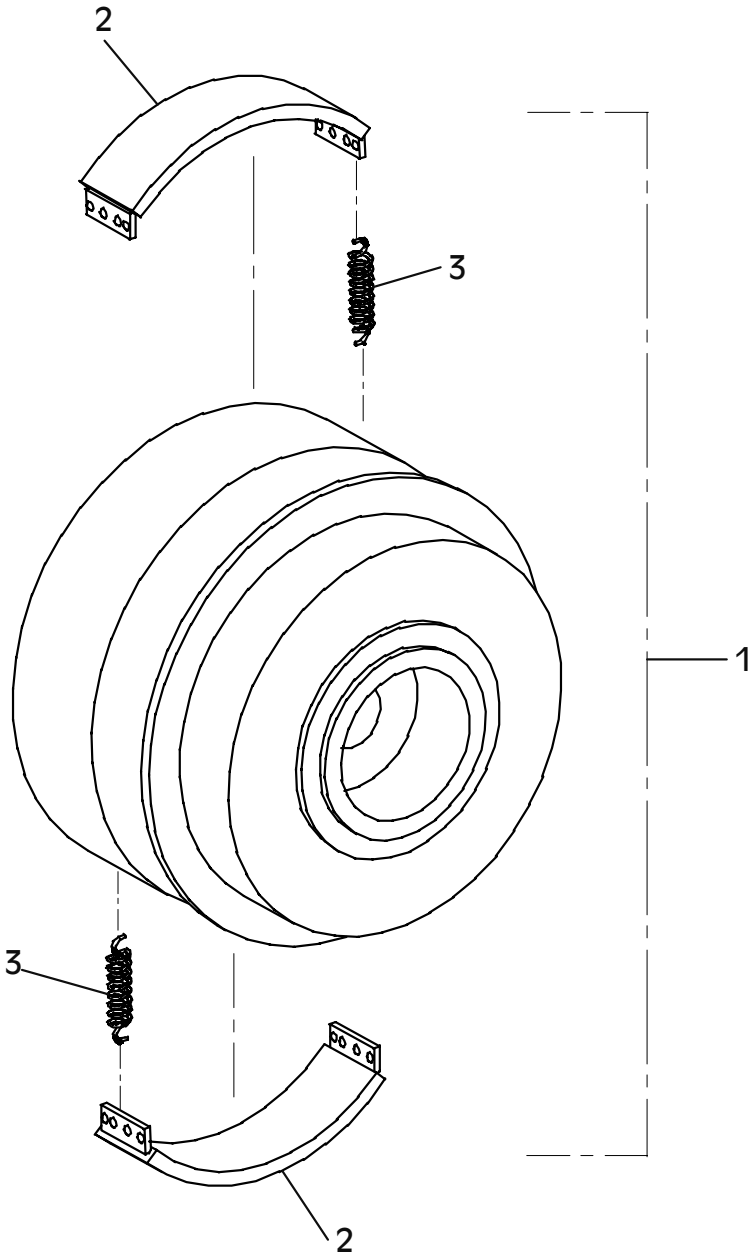

E 3004-0202

## E 3006-0304

Position Ref.No. Repère Posizione Posicion	Menge Quantity Quantité Quantità Cantidad	Teile-Nr. Part-No. No. Référence Nr. d'Ordine No. Referenzia	Hinweis Hints Indications Indicazione Indicaciones	Position Ref.No. Repère Posizione Posicion	Menge Quantity Quantité Quantità Cantidad	Teile-Nr. Part-No. No. Référence Nr. d'Ordine No. Referenzia	Hinweis Hints Indications Indicazione Indicaciones
1	1	10003989					
2	2	25038007	DIN933-M8x20				
3	2	20029003	VSK 8				
4	1	20031502					
5	2	10015530					
6	1	10015675					
7	1	10001253					
8	1	10001416					
9	1	20025566					
10	1	10015828					
11	1	10015631					
12	2	25020028					
13	10	25031003	DIN934-M8				
14	4	20029003	VSK 8				
15	1	10001469					
16	2	25038003	DIN933-M6x20				
17	2	20029020	SKB 6				
18	1	10001476					
19	1	10001427					
20	1	20031541					
21	1	20031532					
22	2	25038035	DIN933-M5x12				
23	2	25048017	DIN125-A5,3				
24	2	25031023	DIN985-M5				

Hatz

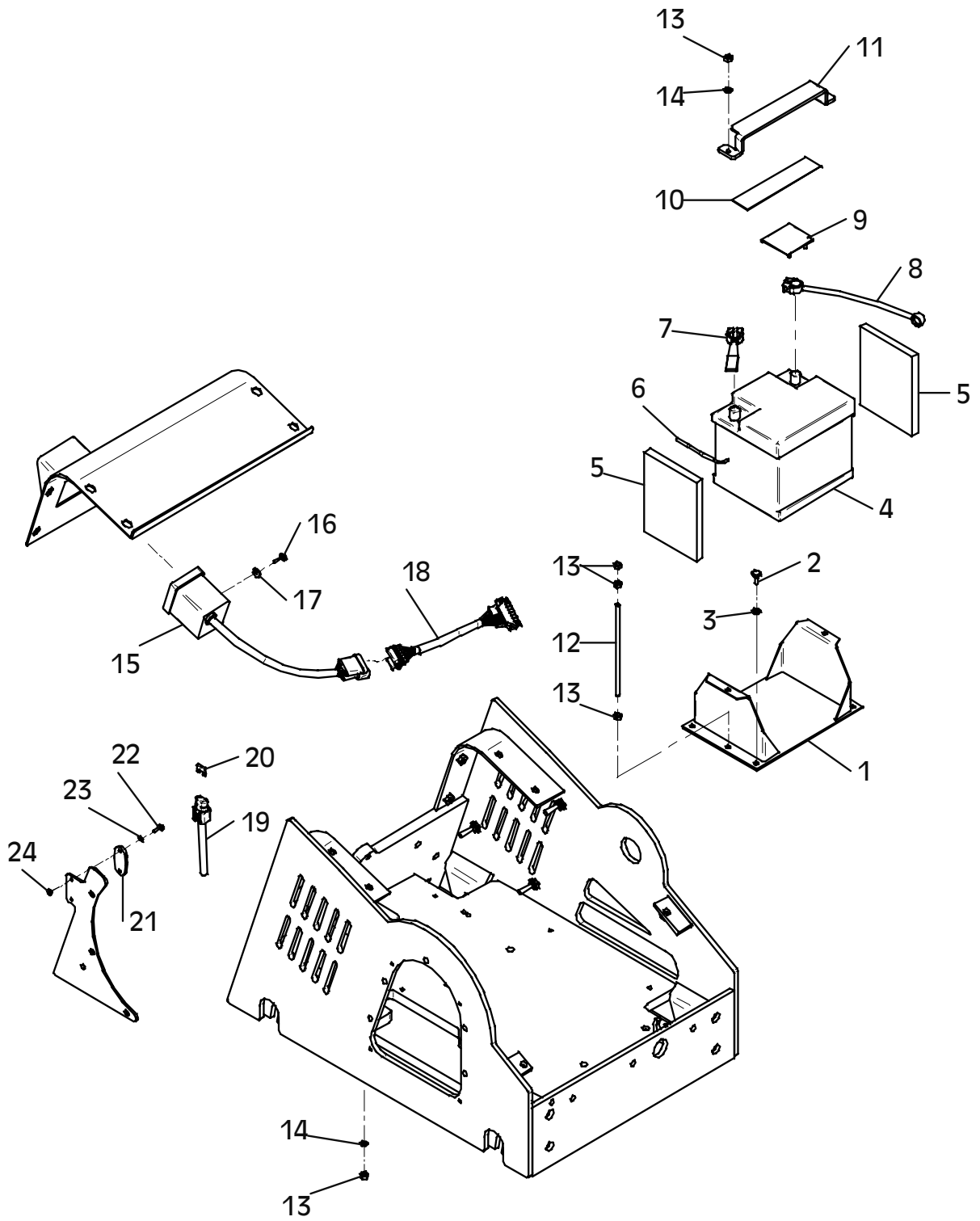

E 3006-0304

## E 3136-0304

Position Ref.No. Repère Posizione Posicion	Menge Quantity Quantité Quantità Cantidad	Teile-Nr. Part-No. No. Référence Nr. d'Ordine No. Referenzia	Hinweis Hints Indications Indicazione Indicaciones	Position Ref. No. Repère Posizione Posicion	Menge Quantity Quantité Quantità Cantidad	Teile-Nr. Part-No. No. Référence Nr. d'Ordine No. Referenzia	Hinweis Hints Indications Indicazione Indicaciones
1	1	10003989		30	1	20031579	
2	2	25038007	DIN933-M8x20	31	1	20026574	
3	2	20029003	VSK 8	32	4	25044080	DIN912-M5x25
4	1	20031502		33	4	20029006	VSK 5
5	2	10015530					
6	1	10015675					
7	1	10001253					
8	1	10001416					
9	1	20025566					
10	1	10015828					
11	1	10015631					
12	2	25020028					
13	10	25031003	DIN934-M8				
14	4	20029003	VSK 8				
15	1	10001469					
16	2	25038003	DIN933-M6x20				
17	2	20029020	SKB 6				
18	1	10001474					
19	1	20026573					
20	4	25033029	ISO7380-M6x16				
21	4	20022001	Tensilock M6				
22	1	20031532					
23	2	25048017	DIN125-A5,3				
24	1	25044076	DIN912-M5x16				
25	1	25044001	DIN912-M5x20				
26	1	20007033					
27	2	25031023	DIN985-M5				
28	1	10001475					
29	1	20031541					

Hatz-CCD

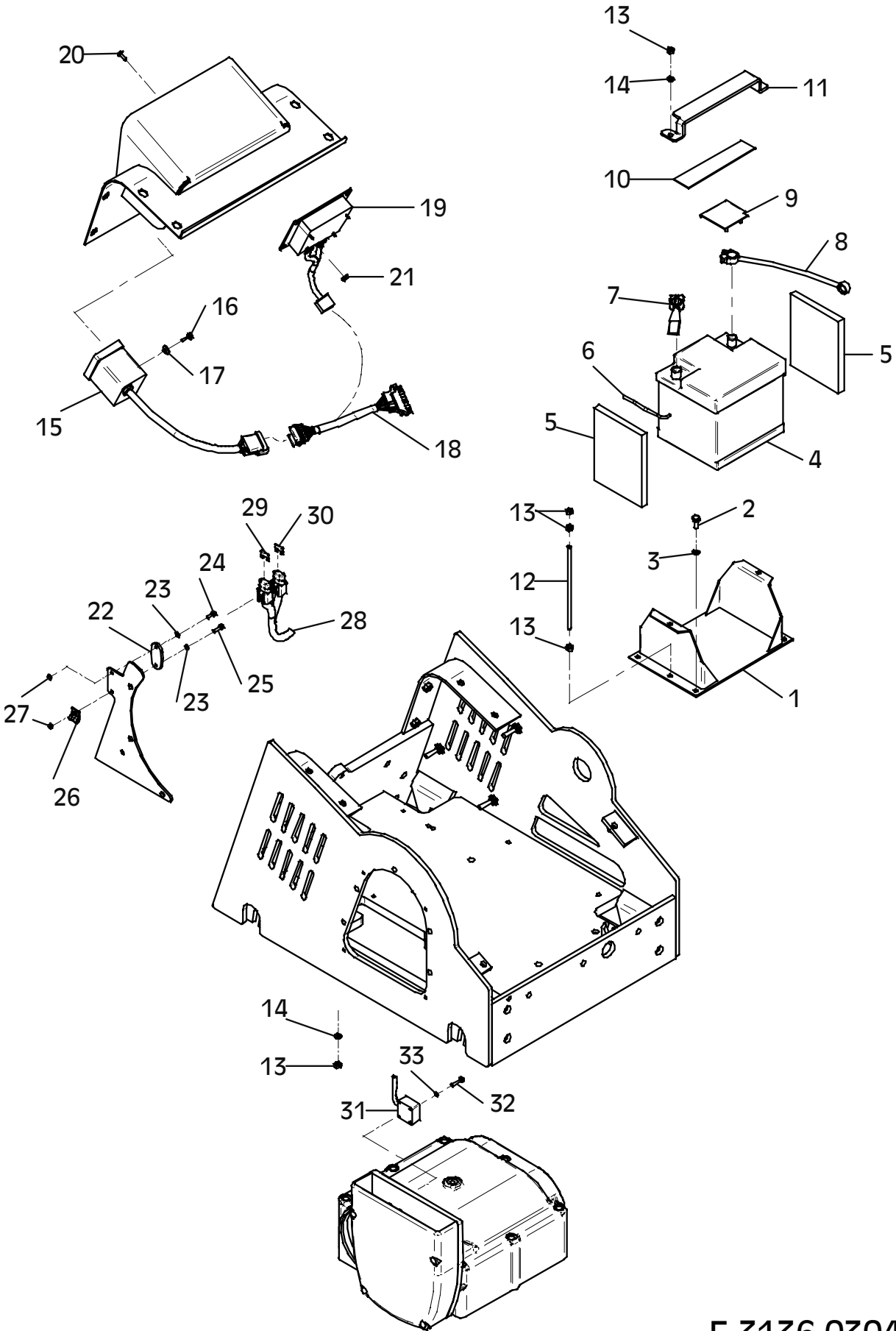

## E 3137-0904

Position Ref.No. Repère Posizione Posicion	Menge Quantity Quantité Quantita Cantidad	Teile-Nr. Part-No. No. Référence Nr. d'Ordine No. Referenzia	Hinweis Hints Indications Indicazione Indicaciones	Position Ref. No. Repère Posizione Posicion	Menge Quantity Quantité Quantita Cantidad	Teile-Nr. Part-No. No. Référence Nr. d'Ordine No. Referenzia	Hinweis Hints Indications Indicazione Indicaciones
1	1	10022647		31	3	25033030	ISO7380-M6x20
2	1	10017164		32	1	20026481	
3	5	25038014	DIN933-M10x25	33	2	25025191	DIN80705-M20x1,5
4	5	25049035	VSF 10	34	2	20025019	
5	1	30047532		35	1	25044037	DIN912-M10x55
6	4	25038006	DIN933-M8x16	36	2	25048003	DIN125-A10,5
7	4	20029003	VSK 8	37	1	25031014	DIN985-M10
8	4	25048002	DIN125-A8,4	38	1	10017320	
9	1	20005006		39	2	25033030	ISO7380-M6x20
10	1	25049029	DIN1052-14x58x6	40	2	25049033	DIN9021-6,4/18x1,6
11	1	20029004	VSK 12	41	2	20022001	Tensilock M6
12	1	25038022	DIN933-M12x40	42	1	20026544	
13	1	10022644		43	1	20026545	
14	1	10017163		44	1	25046021	DIN6912-M8x35
15	5	25044002	DIN912-M6x16	45	3	25049013	DIN440-R11,5
16	5	20022001	Tensilock M6	46	1	20022002	Tensilock M8
17	1	10022646					
18	9	25038014	DIN933-M10x25				
19	9	25049035	VSF 10				
20	2	20007226					
21	1	25038003	DIN933-M6x20				
22	1	25048001	DIN125-B6,4				
23	1	20029007	VSK 6				
24	1	25031002	DIN934-M6				
25	1	10022643					
26	8	25044045	DIN912-M16x40				
27	8	20029029					
28	4	20026565					
29	1	10017038					
30	1	30047480					

Honda-CCD

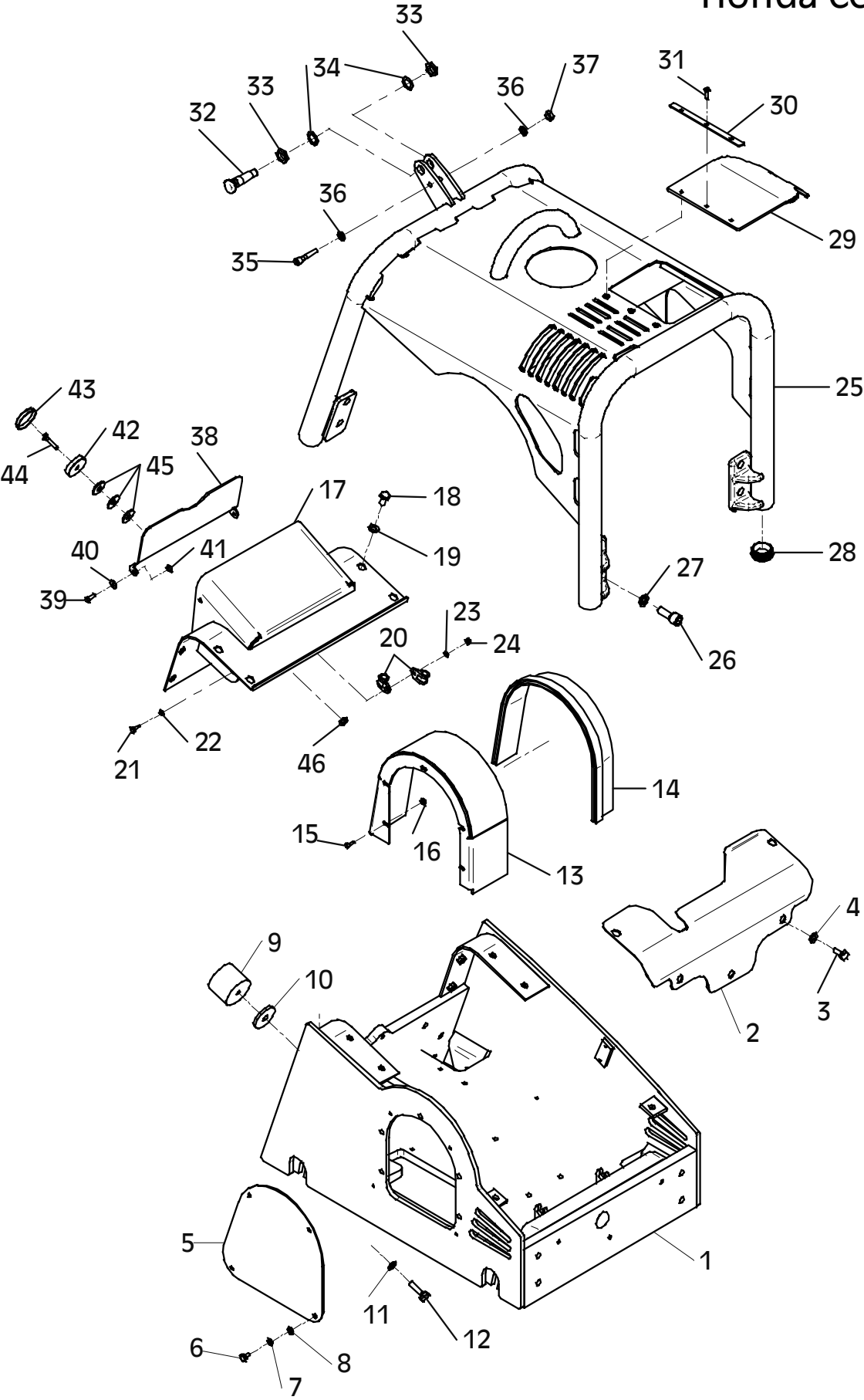

## E 3138-0304

Position Ref.No. Repère Posizione Posicion	Menge Quantity Quantité Quantita Cantidad	Teile-Nr. Part-No. No. Référence Nr. d'Ordine No. Referenzia	Hinweis Hints Indications Indicazione Indicaciones	Position Ref. No. Repère Posizione Posicion	Menge Quantity Quantité Quantita Cantidad	Teile-Nr. Part-No. No. Référence Nr. d'Ordine No. Referenzia	Hinweis Hints Indications Indicazione Indicaciones
1	1	20001247		31	1	25031002	DIN934-M6
2	2	10017175		32	1	20007007	
3	2	10016980		33	1	25048001	DIN125-B6,4
4	4	25033019	DIN603-M10x70	34	1	25038002	DIN933-M6x16
5	4	25049020	DIN7349-10,5	35	1	40001338	
6	4	20029025		36	1	20026383	
7	3	25031004	DIN934-M10				
8	2	25031024	DIN936-M10				
9	1	20026204					
10	1	25008011	DIN7603-12x18x1,5				
11	1	10017191					
12	4	25038006	DIN933-M8x16				
13	4	20025122					
14	1	20002097					
15	1	25002175					
16	1	10017040					
17	1	20026475					
18	1	25040065	DIN931-M8x40				
19	1	20007226					
20	1	25038002	DIN933-M6x16				
21	1	20025704					
22	1	20025434					
23	1	20026559					
24	1	20007024					
25	1	10017036					
26	1	25038002	DIN933-M6x16				
27	1	20029007	VSK 6				
28	1	20015175					
29	1	25044065	DIN912-M6x25				
30	1	20029007	VSK 6				

# Honda-CCD

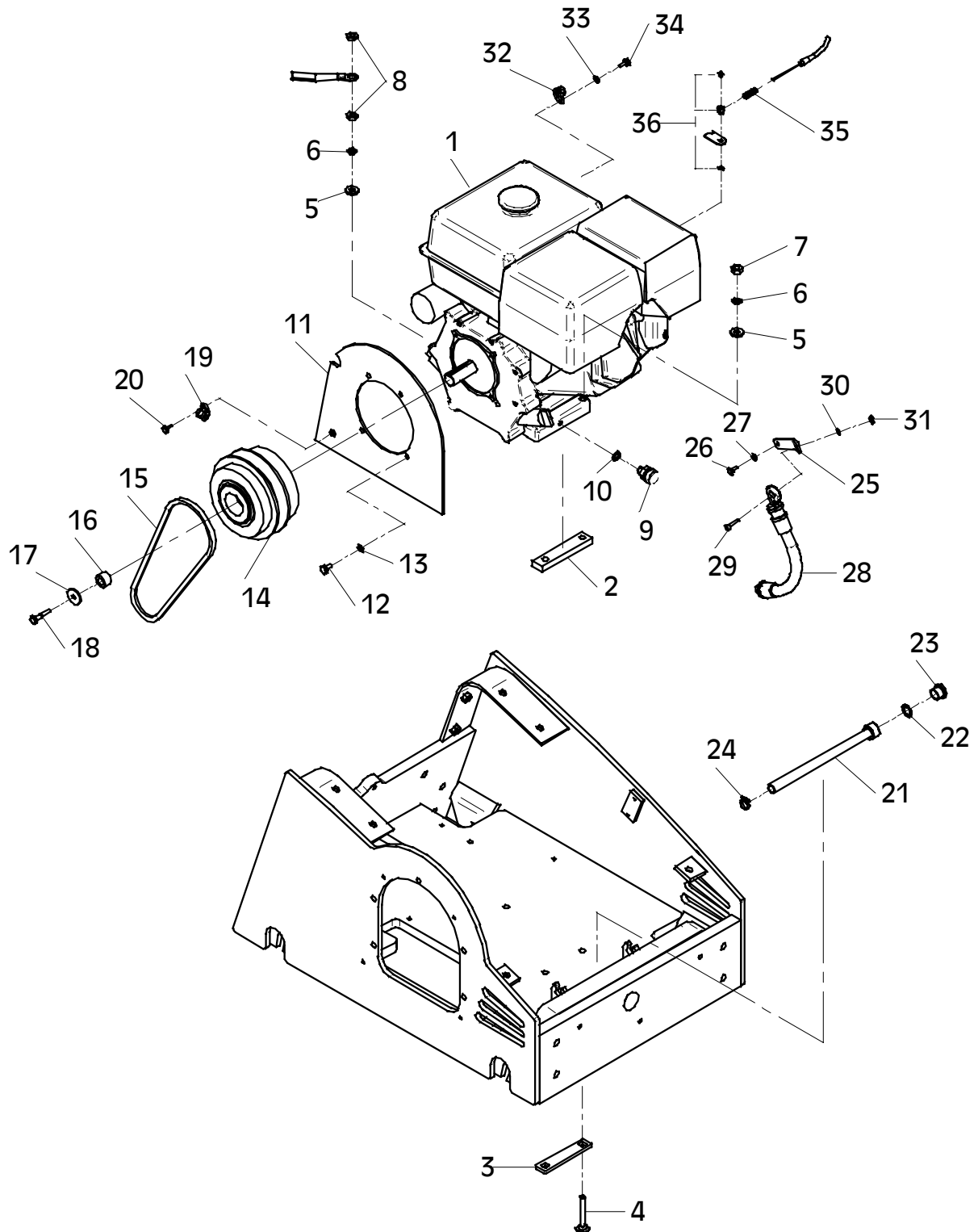

E 3138-0403

## E 3096-0503

Position Ref.No. Repère Posizione Posicion	Menge Quantity Quantité Quantita Cantidad	Teile-Nr. Part-No. No. Référence Nr. d'Ordine No. Referenzia	Hinweis Hints Indications Indicazione Indicaciones	Position Ref. No. Repère Posizione Posicion	Menge Quantity Quantité Quantita Cantidad	Teile-Nr. Part-No. No. Référence Nr. d'Ordine No. Referenzia	Hinweis Hints Indications Indicazione Indicaciones
1	1	20002097					
2	2	20002268					
3	2	20002289					

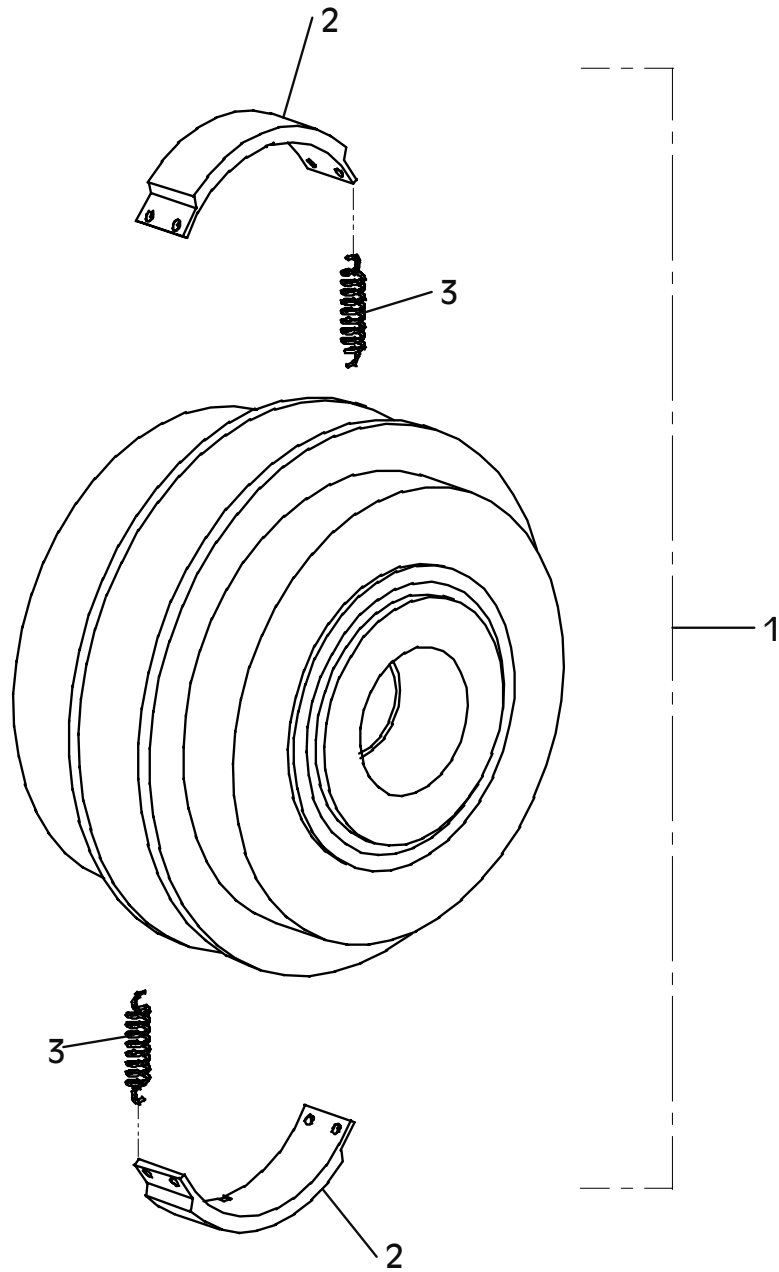

E 3096-0503

## E 3139-0904

Position Ref.No. Repère Posizione Posicion	Menge Quantity Quantité Quantita Cantidad	Teile-Nr. Part-No. No. Référence Nr. d'Ordine No. Referenzia	Hinweis Hints Indications Indicazione Indicaciones	Position Ref. No. Repère Posizione Posicion	Menge Quantity Quantité Quantita Cantidad	Teile-Nr. Part-No. No. Référence Nr. d'Ordine No. Referenzia	Hinweis Hints Indications Indicazione Indicaciones
1	1	10003989		31	2	25044119	DIN912-M5x10
2	2	25038007	DIN933-M8x20	32	2	25048017	DIN125-A5,3
3	2	20029003	VSK 8	33	1	20031526	
4	2	10017185		34	1	25044119	DIN912-M5x10
5	1	20031502		35	1	25048017	DIN125-A5,3
6	2	10015530		36	1	20031034	
7	1	10015675		37	1	20026514	
8	1	10001470		38	1	20007033	
9	1	10001472		39	1	25044076	DIN912-M5x16
10	1	20025566		40	1	20029006	VSK 5
11	1	10015828		41	2	25044003	DIN912-M6x20
12	1	10015631		42	2	20029007	VSK 6
13	2	25020028		43	1	20007062	
14	10	25031003	DIN934-M8	44	1	25038013	DIN933-M10x20
15	4	20029003	VSK 8	45	1	25048003	DIN125-A10,5
16	1	10022649		46	1	10001473	
17	1	20007066		47	1	25049026	DIN7349-8,4
18	1	25048003	DIN125-A10,5	48	1	20007077	
19	1	25044012	DIN912-M10x25	49	1	25048002	DIN125-A8,4
20	1	10001469		50	1	25038007	DIN933-M8x20
21	2	25038003	DIN933-M6x20				
22	2	20029020	SKB 6				
23	1	20026573					
24	4	25033029	ISO7380-M6x16				
25	4	20022001	Tensilock M6				
26	1	20026574					
27	4	25044080	DIN912-M5x25				
28	4	20029006	VSK 5				
29	1	10001471					
30	1	20031532					

# Honda-CCD

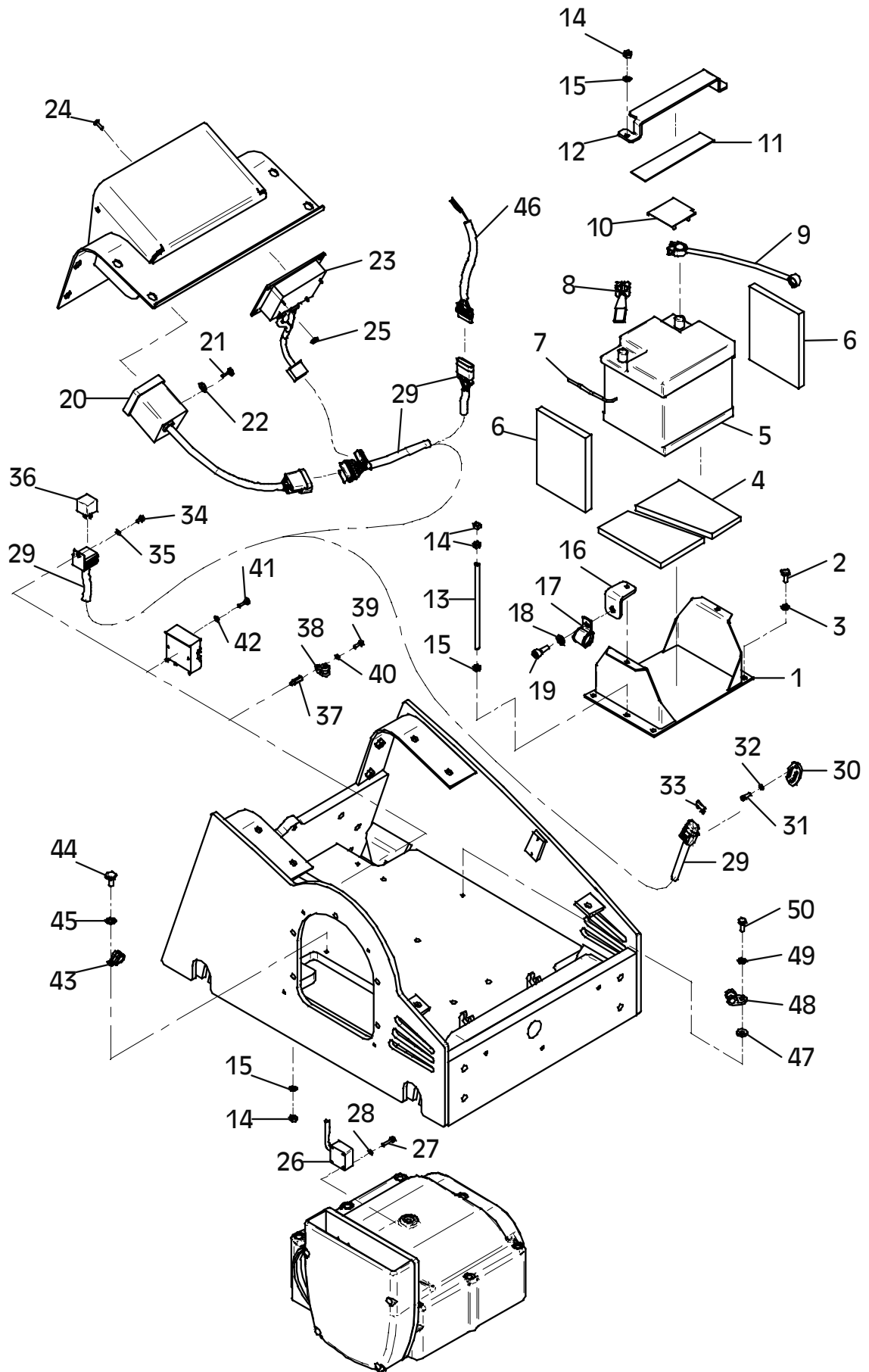

E 3139-0904

## E 3005-0304

Position Ref.No. Repère Posizione Posicion	Menge Quantity Quantité Quantita Cantidad	Teile-Nr. Part-No. No. Référence Nr. d'Ordine No. Referenzia	Hinweis Hints Indications Indicazione Indicaciones	Position Ref. No. Repère Posizione Posicion	Menge Quantity Quantité Quantita Cantidad	Teile-Nr. Part-No. No. Référence Nr. d'Ordine No. Referenzia	Hinweis Hints Indications Indicazione Indicaciones
1	1	10022642		36	2	10022521	
2	1	10022520		37	2	20026468	
3	8	20029022	SKB 10	38	2	20029023	SKB 12
4	8	25038013	DIN933-M10x20	39	2	25038020	DIN933-M12x30
5	2	10016290		41	1	20025764	
6	4	25044055	DIN912-M8x50	42	1	20008069	
7	4	20029003	VSK 8	43	1	10016307	
8	4	25031003	DIN934-M8	44	1	20013282	
9	2	20004016		45	2	20013285	
10	2	10016291		46	1	10016305	
11	2	20029002	VSK 16	47	1	20013286	
12	2	25040066	DIN931-M16x55	48	1	10016303	
13	1	10016294		49	1	10016308	
14	2	20029029		50	4	20025122	
15	2	25044102	DIN912-M16x35	51	4	25044006	DIN912-M8x25
16	1	10016295		52	2	25047022	DIN7991-M6x12
17	2	20029029		53	1	20020562	
18	2	25044102	DIN912-M16x35	54	1	20016367	
19	4	20029003	VSK 8	55	1	20018080	<b>Hatz</b>
20	4	25040056	DIN931-M8x25	55	1	20018160	<b>Honda</b>
21	1	20007089		56	1	20018082	
22	1	10016402		57	1	20018081	<b>Hatz</b>
23	1	25048002	DIN125-A8,4	57	1	20018161	<b>Honda</b>
24	1	25040004	DIN931-M8x55	58	1	20018143	
25	1	20007089		59	2	20029007	VSK 6
26	1	10015676		60	2	25040067	DIN931-M6x30
27	1	20029003	VSK 8	61	2	20026492	
28	1	25040027	DIN931-M8x35	62	2	20026491	
29	1	10016309		63	1	10016100	
30	1	25008019	DIN 7603-26x32x2				
31	1	25030018	DIN908-M26x1,5				
32	1	10016306					
33	2	20013284					
34	2	10016304					
35	2	20013283					

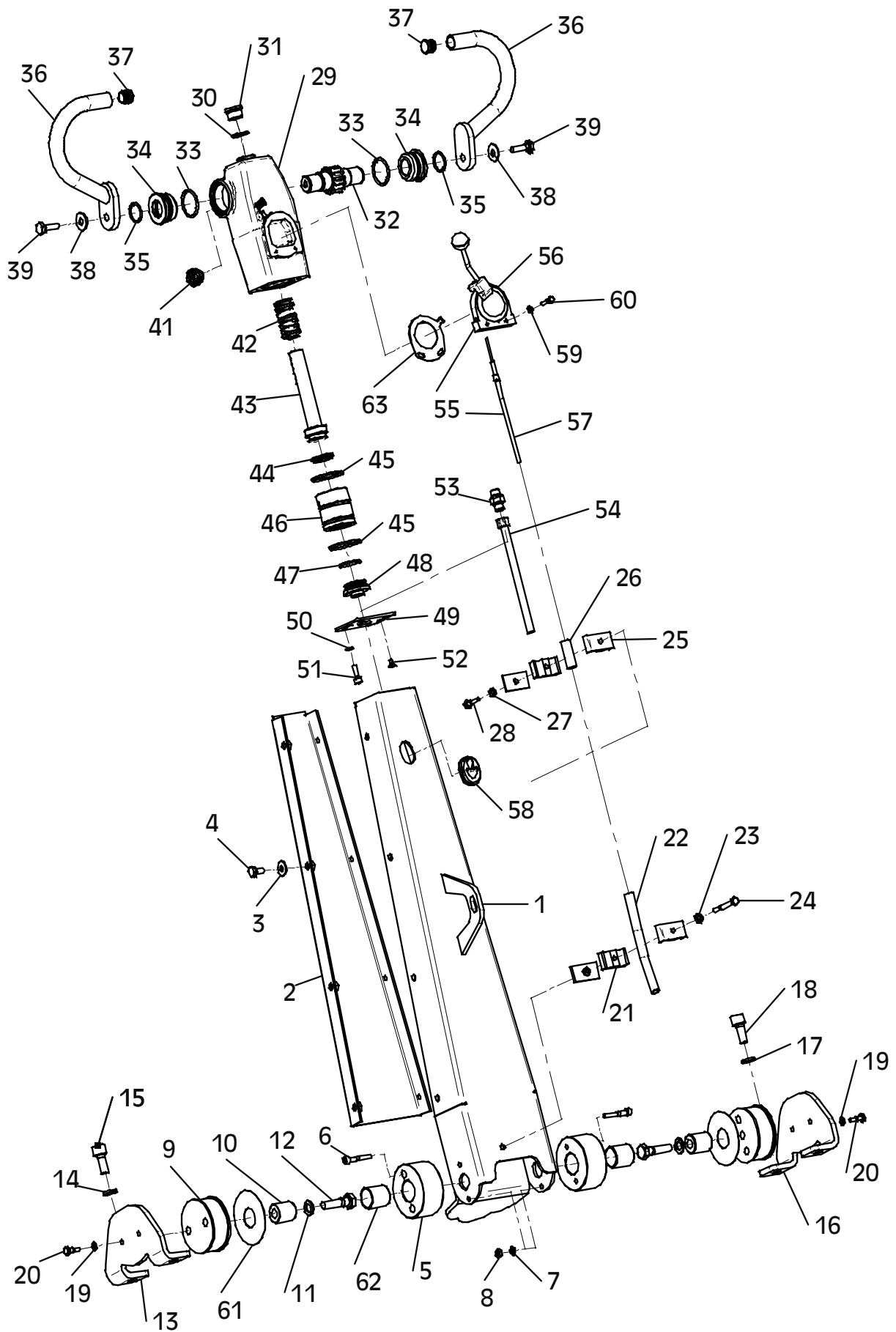

E 3005-0304

## E 3007-0202

Position Ref.No. Repère Posizione Posicion	Menge Quantity Quantité Quantita Cantidad	Teile-Nr. Part-No. No. Référence Nr. d'Ordine No. Referenzia	Hinweis Hints Indications Indicazione Indicaciones	Position Ref. No. Repère Posizione Posicion	Menge Quantity Quantité Quantita Cantidad	Teile-Nr. Part-No. No. Référence Nr. d'Ordine No. Referenzia	Hinweis Hints Indications Indicazione Indicaciones
1	1	10016451					
2	2	10016452					
3	6	25038076	DIN933-M12x100				
4	6	20029004	VSK 12				
5	6	25031005	DIN934-M12				

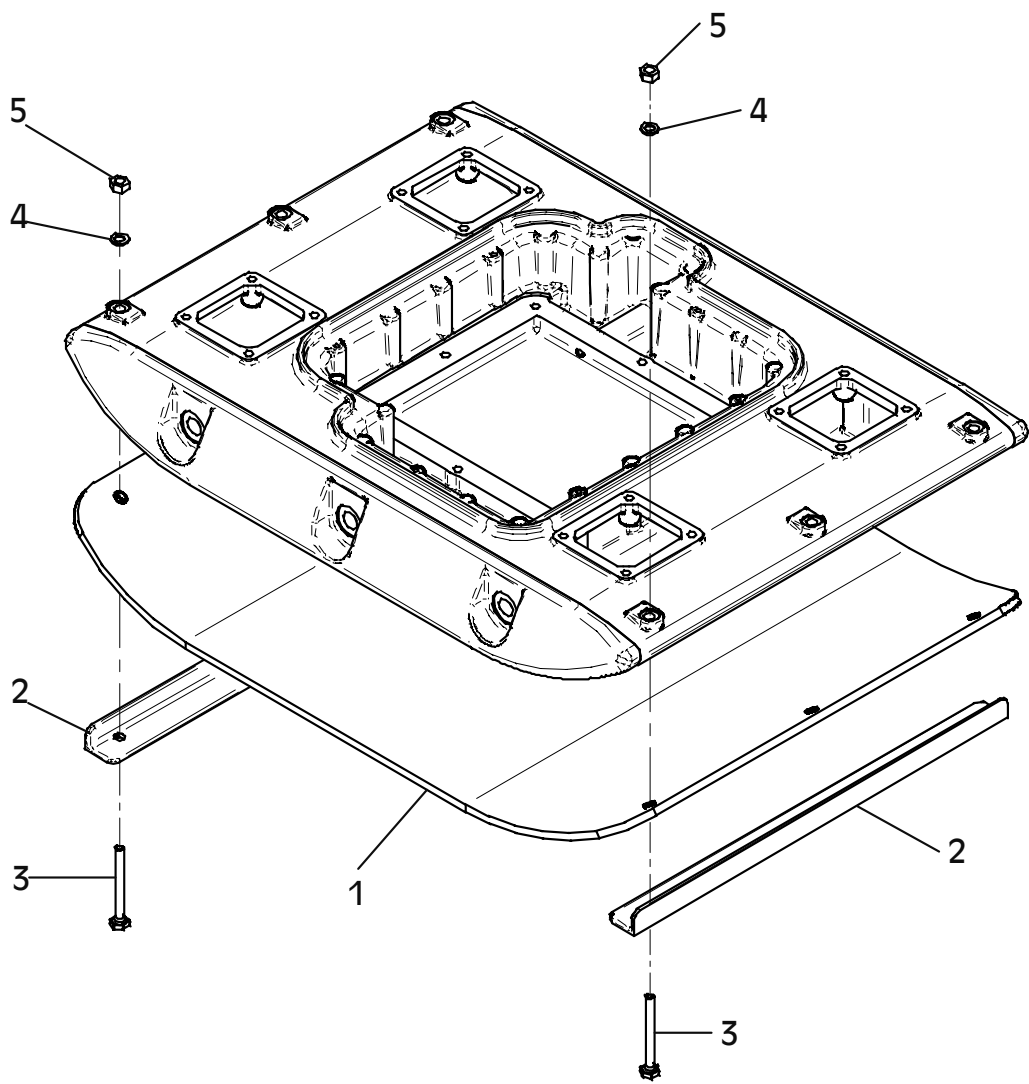

E 3007-0202

## E 3041-0402

Position Ref.No. Repère Posizione Posicion	Menge Quantity Quantité Quantita Cantidad	Teile-Nr. Part-No. No. Référence Nr. d'Ordine No. Referenzia	Hinweis Hints Indications Indicazione Indicaciones	Position Ref. No. Repère Posizione Posicion	Menge Quantity Quantité Quantita Cantidad	Teile-Nr. Part-No. No. Référence Nr. d'Ordine No. Referenzia	Hinweis Hints Indications Indicazione Indicaciones
1	2	10016443					
2	6	20029009	VSK 20				
3	6	25038084	DIN933-M20x100				
4	1	10016699					
5	2	10016702					
6	6	25038076	DIN933-M12x100				
7	6	20029004	VSK 12				
8	6	25031005	DIN934-M12				

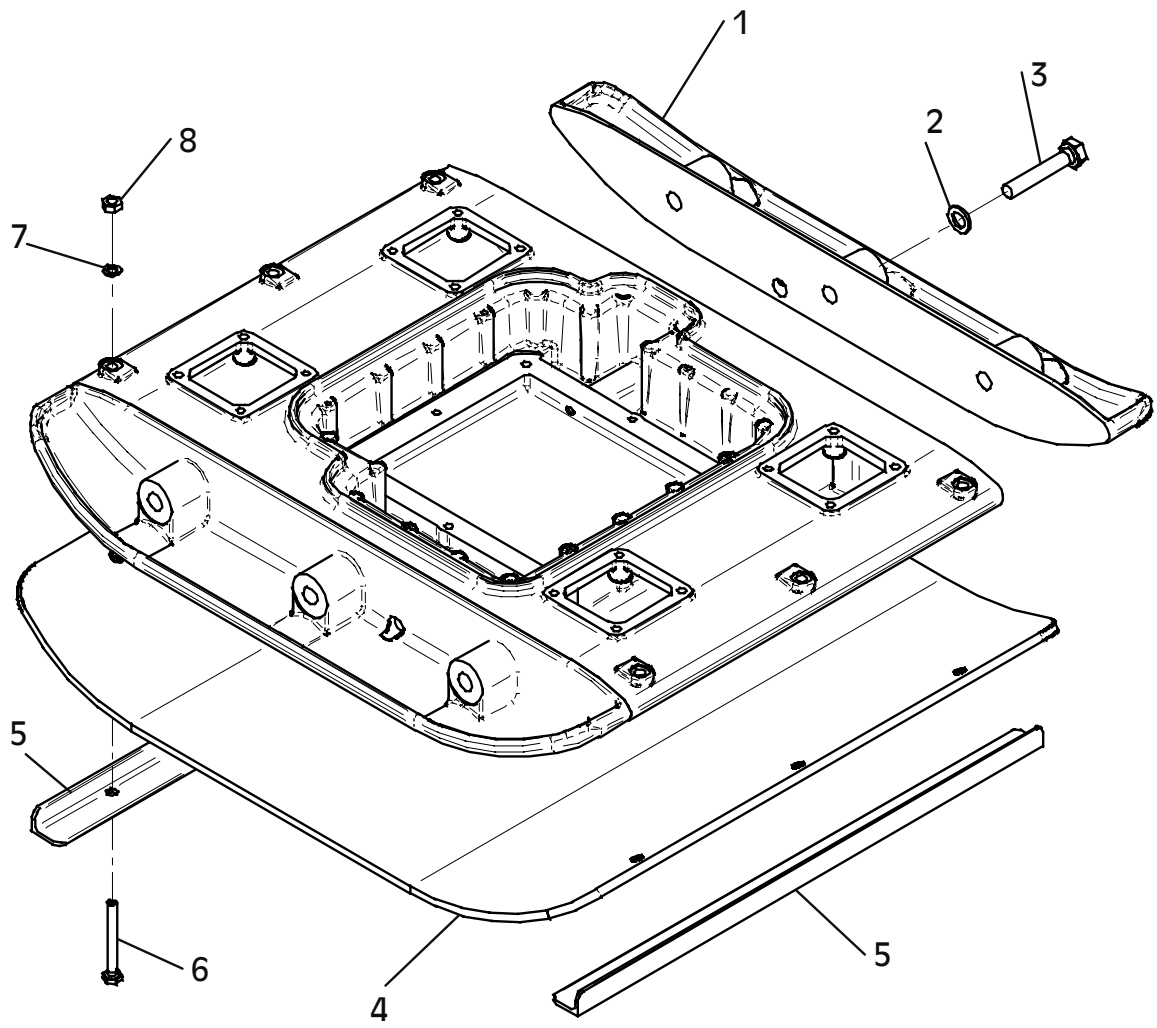

E 3041-0402

## E 3134-0304

Position Ref.No. Repère Posizione Posicion	Menge Quantity Quantité Quantita Cantidad	Teile-Nr. Part-No. No. Référence Nr. d'Ordine No. Referenzia	Hinweis Hints Indications Indicazione Indicaciones	Position Ref. No. Repère Posizione Posicion	Menge Quantity Quantité Quantita Cantidad	Teile-Nr. Part-No. No. Référence Nr. d'Ordine No. Referenzia	Hinweis Hints Indications Indicazione Indicaciones
1	2	10016746					
2	6	25038032	DIN933-M20x40				
3	6	20029009	VSK 20				

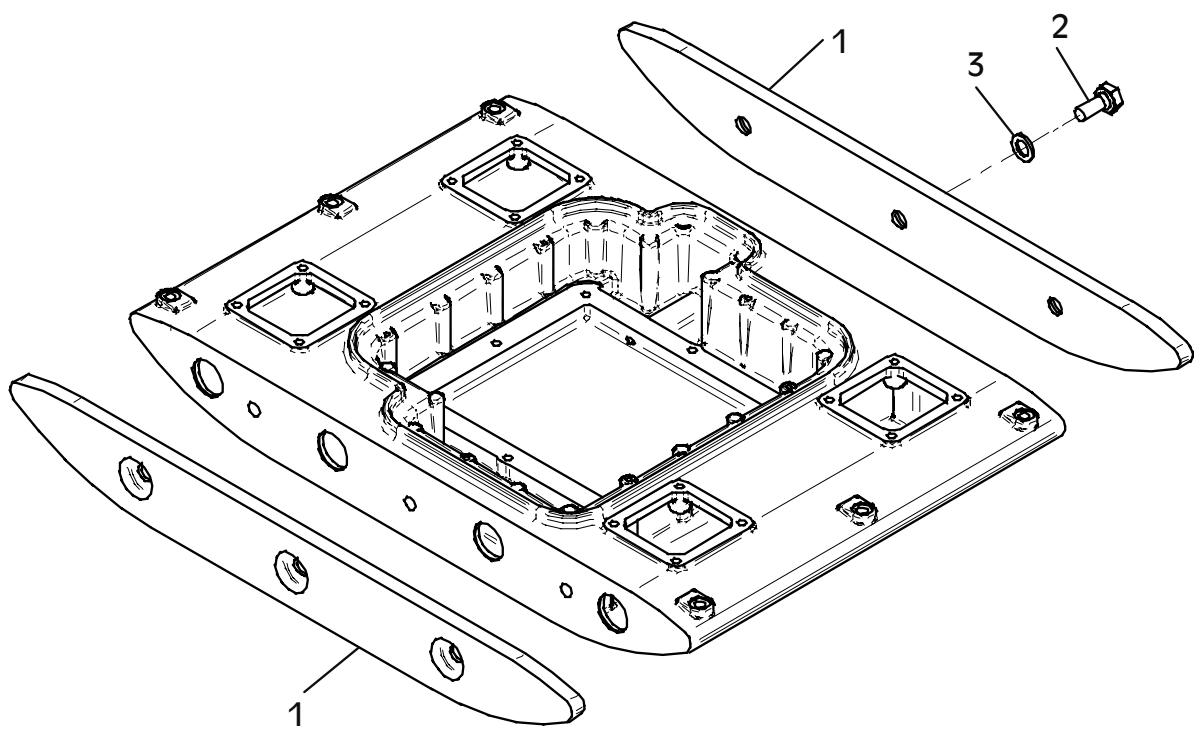

E 3134-0304

## E 3042-0304

Position Ref.No. Repère Posizione Posicion	Menge Quantity Quantité Quantita Cantidad	Teile-Nr. Part-No. No. Référence Nr. d'Ordine No. Referenzia	Hinweis Hints Indications Indicazione Indicaciones	Position Ref. No. Repère Posizione Posicion	Menge Quantity Quantité Quantita Cantidad	Teile-Nr. Part-No. No. Référence Nr. d'Ordine No. Referenzia	Hinweis Hints Indications Indicazione Indicaciones
1	1	10006815					
2	1	10006816					
3	1	20005004					
4	1	20029003	VSK 8				
5	1	25031003	DIN934-M8				
6	2	25048002	DIN125-A8,4				
7	2	25038008	DIN933-M8x25				
8	2	20029003	VSK 8				
9	2	25031003	DIN934-M8				
10	1	20015034					
11	1	20015072					

# Hatz / Hatz-CCD

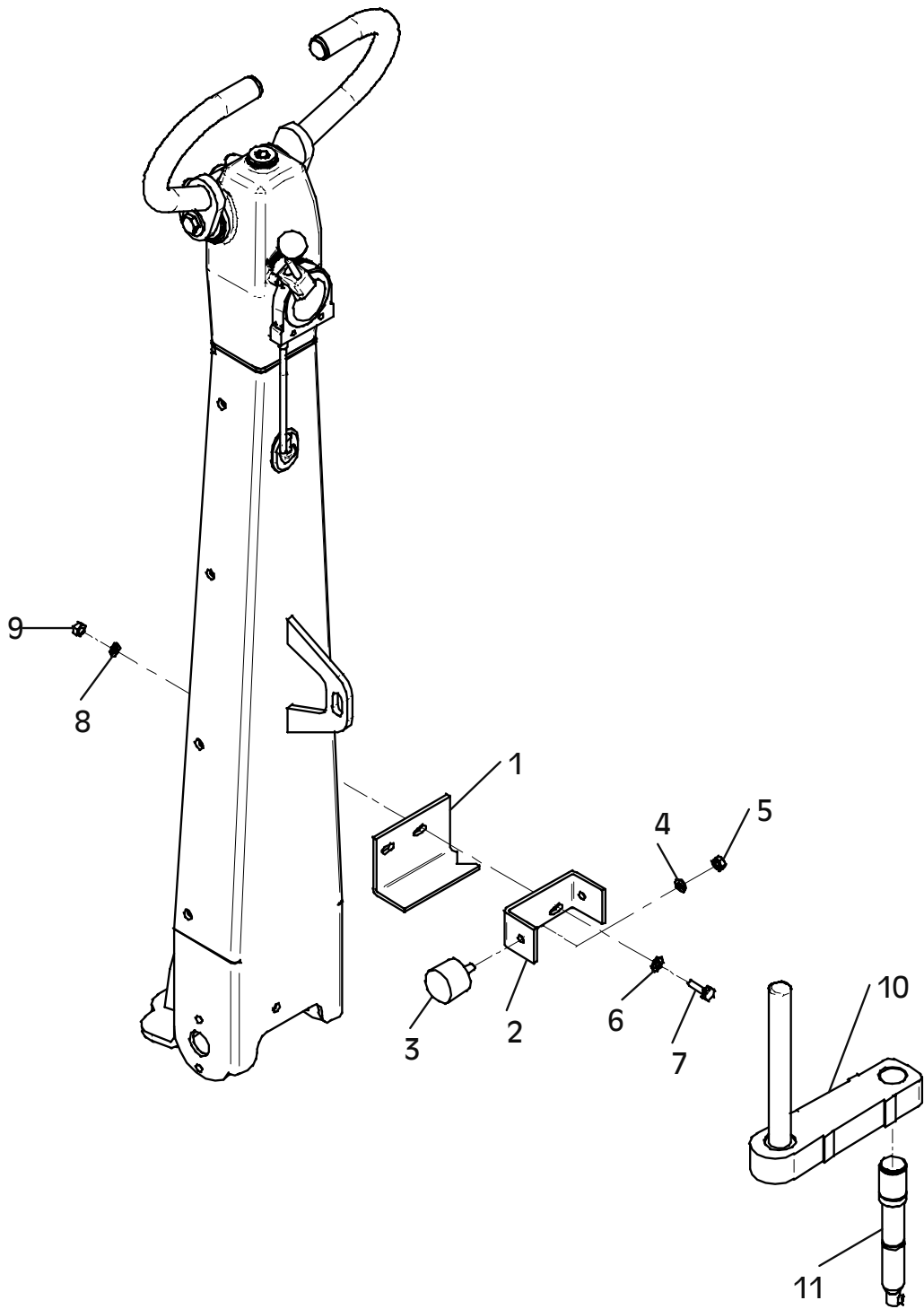

E 3042-0304



**Wenn Sie Fragen und Anregungen haben, oder sonstige Informationen benötigen,  
wenden Sie sich bitte an eine der unten genannten Adressen:**

**For questions and further information refer to one of the  
following addresses:**

<p><b>In Deutschland</b>  <b>In Germany</b></p>	<p>WEBER Maschinentechnik GmbH Postfach 2153 57329 Bad Laasphe – Rückershausen</p> <p>Information / information: E-mail: info@webermt.de Ersatzteile / spare parts: E-mail: parts@webermt.de</p>	<p>Telefon / phone:  Telefax / fax:  Telefax / fax:</p>	<p>+49 (0) 2754 / 3980 Zentrale / switchboard  +49 (0) 2754 / 398101 Zentrale / switchboard  +49 (0) 2754 / 398102 Ersatzteile / spare parts direct dial</p>
<p><b>In Holland</b>  <b>In Netherlands</b></p>	<p>WEBER Maschinentechnik B.V. Graafschap Hornelaan 159 6001 AC Weert</p> <p>E-mail: info@webermt.nl</p>	<p>Telefon / phone:  Telefax / fax:</p>	<p>+31 (0) 495 / 530215  +31 (0) 495 / 541839</p>
<p><b>In Frankreich</b>  <b>In France</b></p>	<p>WEBER Technologie S.A.R.L. 26, rue d' Arsonval 69680 Chassieu</p> <p>E-mail: france@webermt.com</p>	<p>Telefon / phone:  Telefax / fax:</p>	<p>+33 (0) 472 / 791020  +33 (0) 472 / 791021</p>
<p><b>In Polen</b>  <b>In Poland</b></p>	<p>WEBER Maschinentechnik SP.ZO.O. ul. Grodziska 7 05-830 Stara Wies / Nadarzyn</p> <p>E-mail: info@webermt.com.pl</p>	<p>Telefon / phone:  Telefax / fax:</p>	<p>+48 (0) 22 / 7397080 +48 (0) 22 / 7397081  +48 (0) 22 / 7397082</p>
<p><b>In USA, Kanada</b>  <b>In USA, Canada</b></p>	<p>WEBER Machine (USA), Inc. 40 Johnson Ave 112 Bangor, ME 04401 USA</p> <p>E-mail: usa@webermt.com</p>	<p>Telefon / phone:  Telefax / fax:</p>	<p>+1 (0) 207 / 9474990  +1 (0) 207 / 9475452</p>
<p><b>In Südamerika</b>  <b>In South America</b></p>	<p>WEBER Maschinentechnik do Brasil Ltda. Rua Sete de Setembro, 275 93332-470 Novo Hamburgo, RS Brasil</p> <p>E-mail: webermt@webermt.com.br</p>	<p>Telefon / phone:  Telefax / fax:</p>	<p>+55 (0) 51 / 5873044  +55 (0) 51 / 5872271</p>

<http://www.webermt.com>

