



ERSATZTEILLISTE

SPARE PARTS LIST

**LISTE DES PIECES
DE RECHANGE**

LISTINO RICAMBI

LISTA DE RECAMBIOS

**WYKAZ CZESCI
ZAMIENNYCH**



CR 7

0116601-0116607

Ab Masch.-Nr. 7009258



Weber Maschinenteknik GmbH

Postfach 2153, 57329 Bad Laasphe-Rückershausen

Telefon 02754 / 398-0

Telefax (02754) 398-101 (Zentrale) u. 398-102 (Ersatzteile)

EG - KONFORMITÄTSERKLÄRUNG

EC DECLARATION OF CONFORMITY/ DECLARATION DE CONFORMITE CE
DICHIAZIONE CE DI CONFORMITA / DECLARACION CE DE CONFORMIDAD
EG-VERKLARING VAN OVEREENSTEMMING / EF-OVERENSSTEMMELSESERKAERING
DECLARACAO CE DE CONFORMIDADE / EG-FÖRSÄKRAN OM ÖVERENSSTÄMMELSE
DEKLARACJA ZGODNOŚCI[TK5]

im Sinne der EG-Maschinenrichtlinie 98/37/EG
und der EG Richtlinie 2000/14/EG – Geräuschemissionen

- I **Hersteller/ Make / Marque / Marca / Marca / Producent / Merk / Marca /**
Tillverkare / Producent **Weber Maschinentechnik GmbH**
Im Boden 5-8,10
57334 Bad Laasphe
- II **Art / Category / Catégorie / Categoria Tipo / Kategori /**
Soort / Categoria / kategori / Typ **Vibrationsplatte**
- III **Typ / Type / Type / Tipo / Codice / Type / Type / Tipo / Typ /**
CR 7 , CR 7 CCD ,
CR 7 MSM
- IV **Nennleistung / Nominal-performance / La puissance nominale / Prestazione nominale /**
Potencia nominal / Nominaal vermogen / Nominel ydelse / Potência nominal / Nominell
effect / Moc **P = 8,1 kW**
- V **gemessener Schalleistungspegel / measured sound power level / niveau de**
puissance acoustique mesure / livello di potenza sonora rilevato / nivel de potencia
acústica medido / gemeten geluidsvermogensniveau / målt lydtekniveau / Nivel de
potência sonora midido / uppmätt ljudteknivå / Mierzony poziom dźwięku **LWA = 108 dB (A)**
- VI **garantierter Schalleistungspegel / guaranteed sound power level / niveau de**
puissance acoustique garanti / livello di potenza sonora garantito / nivel de potencia
acustica garantizado / gewaarborgd geluidsvermogensniveau / garanteret lydtekniveau /
Nivel sonoro garantido / garanterad ljudteknivå / Natężenie hałas **LWA = 109 dB (A)**
- VII **beteiligte Zertifizierungsstelle / notified body involved / de l'organisme notifié/**
dell'organismo notificato che l'ha effettuata / dirección del organismo notificado que haya
intervenido / betrokken aangemelde instantie / pagældende bemyndigede organ /
organismo notificado envolvido / berörda anmälda organets namn / Jednostka
certyfikująca **RWTÜV**
Postfach 103161
D-45032 Essen
- VIII **Konformitäts-Bewertungsverfahren / Conformity assessment procedure followed /**
la procédure appliquée pour l'évaluation de la conformité et / procedura di valutazione
della conformità / procedimiento de evaluación de la conformidad / gevolgde
overeenstemmingsbeoordelingsprocedure / den fulgte
overensstemmelsesvurderingsprocedure / procedimento de avaliacao de conformidade
/Wilket förfarande för bedömning av överensstämmelse / Przebieg kontroli **interne Fertigungskontrolle**
nach Anhang VI
EG Richtlinie 2000/14/EG

ist in Übereinstimmung mit folgenden Richtlinien hergestellt worden /has been produced in accordance with following
standards / est produit conforme aux dispositions des directives européennes ci-apres / ha sido fabricado en conformidad con las
siguientes normas / é stato fabbricato in conformità alle sequenti norme / er blevet fremstillet i overensstemmelse med følgende
retningslinier / in overeenstemming met de volgende voorschriften gefabriceerd is / é fabricado conforme as seguintes normas / har
tillverkats i överensstämmelse med följande riktlinjer / Zgodność z obowiązującymi przepisami

98/37/EG Maschinenrichtlinie des europäischen Parlamentes und des Rates vom 22. Juni 1998
2000/14/EG EG-Richtlinie Geräuschemissionen vom 8. Mai 2000
2005/88/EG EG-Richtlinie vom 14. Dez. 2005 zur Änderung der Richtlinie 2000/14/EG
EN 500 Teil 1 Bewegliche Straßenbaumaschinen – Sicherheit
Gemeinsame Anforderungen
EN 500 Teil 4 Bewegliche Straßenbaumaschinen – Sicherheit
Besondere Anforderungen an Verdichtungsmaschinen

Bescheinigung bitte sorgfältig aufbewahren / File certificate carefully / Conserver certificat soigneusement / Conserver
certificado cuidadosamente / Pregasi conservare accuratamente certificato / Beviset bedes opbevares omhyggeligt / Verklaring a.u.b.
zorgvuldig bevar / Conservar o certificado com cuidado / Beviset skall om sorgsfullt bevaras // Deklarację zgodności proszę zachować

Bad Laasphe – Rückershausen, den **02.01.2007**

W. Weber, Geschäftsführer

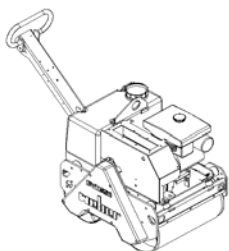

weber_{mt}

WEBER Maschinentechnik GmbH

Im Boden 5-8, 10 – D-57334 Bad Laasphe
Postfach 2153 – D-57329 Bad Laasphe
Telefon: 02754/398-0 – Fax 02754/398-101
E-mail: Verkauf@webermt.de
Internet: <http://www.webermt.de>



EG - KONFORMITÄTSERKLÄRUNG

EC DECLARATION OF CONFORMITY/ DECLARATION DE CONFORMITE CE
DICHIARAZIONE CE DI CONFORMITA / DECLARACION CE DE CONFORMIDAD
EG-VERKLARING VAN OVEREENSTEMMING / EF-OVERENSSTEMMELSESERKAERING
DECLARACAO CE DE CONFORMIDADE / EG-FÖRSÄKRAN OM ÖVERENSSTÄMMELSE
DEKLARACJA ZGODNOŚCI[TK5]

im Sinne der EG-Maschinenrichtlinie 98/37/EG und der EG Richtlinie 2000/14/EG – Geräuschemissionen

- I **Hersteller/** Make / Marque / Marca / Marca / Producent / Merk / Marca /
Tillverkare / Producent **Weber Maschinentechnik GmbH**
Im Boden 5-8,10
57334 Bad Laasphe
- II **Art /** Category / Catégorie / Categoria Tipo / Kategori /
Soort / Categoria / kategori / Typ **Vibrationsplatte**
- III **Typ /** Type / Type / Tipo / Codice / Type / Type / Tipo / Typ / **CR 7 Hd**
- IV **Nennleistung /** Nominal-performance / La puissance nominale / Prestazione nominale /
Potencia nominal / Nominaal vermogen / Nominel ydelse / Potência nominal / Nominell
effect / Moc **P = 9,6 kW**
- V **gemessener Schalleistungspegel /** measured sound power level / niveau de
puissance acoustique mesure / livello di potenza sonora rilevato / nivel de potencia
acústica medido / gemeten geluidsvermogensniveau / målt lydeffektniveau / Nivel de
potência sonora midido / uppmätt ljudeffektnivå / Mierzony poziom dźwięku **LWA = 107 dB (A)**
- VI **garantierter Schalleistungspegel /** guaranteed sound power level / niveau de
puissance acoustique garanti / livello di potenza sonora garantito / nivel de potencia
acustica garantizado / gewaarborgd geluidsvermogensniveau / garanteret lydeffektniveau /
Nivel sonoro garantido / garanterad ljudeffektniva / Natężenie hałasu **LWA = 109 dB (A)**
- VII **beteiligte Zertifizierungsstelle /** notified body involved / de l'organisme notifié/
dell'organismo notificato che l'ha effettuata / dirección del organismo notificado que haya
intervenido / betrokken aangemelde instantie / pagældende bemyndigede organ /
organismo notificado involucrado / berörda anmälda organets namn / Jednostka
certyfikująca **RWTÜV**
Postfach 103161
D-45032 Essen
- VIII **Konformitäts-Bewertungsverfahren /** Conformity assessment procedure followed /
la procédure appliquée pour l'évaluation de la conformité et / procedura di valutazione
della conformità / procedimiento de evaluación de la conformidad / gevolgde
overeenstemmingsbeoordelingsprocedure / den fulgte
overensstemmelssesvurderingsprocedure / procedimento de avaliação de conformidade
/Vilket förfarande för bedömning av överensstämmelse / Przebieg kontroli **interne Fertigungskontrolle**
nach Anhang VI
EG Richtlinie 2000/14/EG

ist in Übereinstimmung mit folgenden Richtlinien hergestellt worden /has been produced in accordance with following standards / est produit conforme aux dispositions des directives europeenes ci-apres / ha sido fabricado en conformidad con las siguientes normas / é stato fabbricato in conformità alle sequenti norme / er blevet fremstillet i overensstemmelse med følgende retningslinier / in overensstemming med de følgende voorschriften gefabriceerd is / é fabricado conforme as seguintes normas / har tillverkats i överensstämmelse med följande riktlinjer / Zgodność z obowiązującymi przepisami

98/37/EG Maschinenrichtlinie des europäischen Parlamentes und des Rates vom 22. Juni 1998
2000/14/EG EG-Richtlinie Geräuschemissionen vom 8. Mai 2000
2005/88/EG EG-Richtlinie vom 14. Dez. 2005 zur Änderung der Richtlinie 2000/14/EG
EN 500 Teil 1 Bewegliche Straßenbaumaschinen – Sicherheit
Gemeinsame Anforderungen
EN 500 Teil 4 Bewegliche Straßenbaumaschinen – Sicherheit
Besondere Anforderungen an Verdichtungsmaschinen

Bescheinigung bitte sorgfältig aufbewahren / File certificate carefully / Conserver certificat soigneusement / Conservar certificado cuidadosamente / Pregasi conservare accuratamente certificato / Beviset bedes opbevares omhyggeligt / Verklaring a.u.b. zorgvuldig bevar / Conservar o certificado com cuidado / Beviset skall om sorgsfullt bevaras // Deklarację zgodności proszę zachować

Bad Laasphe – Rückershausen, den **02.01.2007**

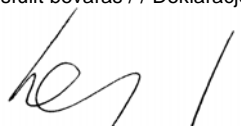
W. Weber, Geschäftsführer

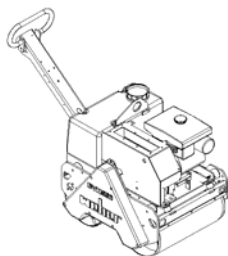

weber_{mt}

WEBER Maschinentechnik GmbH
Im Boden 5-8, 10 – D-57334 Bad Laasphe
Postfach 2153 – D-57329 Bad Laasphe
Telefon: 02754/398-0 – Fax 02754/398-101
E-mail: Verkauf@webermt.de
Internet: <http://www.webermt.de>



BITTE, NOTIEREN SIE SERIENNUMMER UND MOTORNUMMER IHRER MASCHINE:

PLEASE WRITE DOWN SERIALNUMBERS OF MACHINE AND ENGINE:

NOTEZ SVP LE NUMERO DE SERIE ET LE NUMERO DU MOTEUR DE VOTRE MACHINE:

SI PREGA DI ANNOTARE SEMPRE I NUMERI DI SERIE SIA DELLA VS. MACCHINA CHE DEL MOTORE:

MAQUINA: ROGAMOS ANOTEN EL NUMERO DE SERIE Y NUMERO DE MOTOR DE SU MAQUINA:

MASCHINE
MACHINE
MACCHINA
MAQUINA

#

MOTOR
ENGINE
MOTEUR
MOTORE

#

ZUR VERMEIDUNG VON FEHLLIEFERUNGEN UND VERZÖGERUNGEN SIND BEI DER BESTELLUNG VON ERSATZTEILEN FOLGENDE ANGABEN UNBEDINGT ERFORDERLICH:

- MASCHINENTYP
- SERIENNUMMER DER MASCHINE
- SERIENNUMMER DES MOTORS (BEI MOTORTEILEN)
- TEILENUMMER
- BESTELLMENGE

TO AVOID ERRORS IN DELIVERY PLEASE STATE THESE PARTICULARS WHEN ORDERING:

- TYPE OF MACHINE
- SERIAL NO. OF MACHINE
- SERIAL NO. OF ENGINE (ON ENGINE PARTS)
- PART-NO.
- QUANTITY REQUIRED

AFIN D'EVITER DES ERREURS DE COMMANDE ET DES RETARDS DE LIVRAISON IL EST NECESSAIRE D'INDIQUER LES CARACTERISTIQUES SUIVANTES:

- TYPE DE MACHINE
- LE NUMERO DE SERIE DE LA MACHINE
- LE NUMERO DE SERIE DU MOTEUR
- LE NUMERO D'IDENTITE DE LA PIECE
- LA QUANTITE SOUHAITEE

ONDE EVITARE DISGUIDI E RITARDI NELLE CONSEGNE DIE RICAMBI SI PREGA DI INDICARE SEMPRE:

- TIPO DELLA MACCHINA
- NUMERO DI SERIE DELLA MACCHINA
- NUMERO DI SERIE DEL MOTORE (SE SI RICHIEDONO PEZZI DEL MOTORE)
- NUMERO D'ORDINE DIE SINGOLI RICAMBI
- QUANTITA

A FI DE EVITAR ERRORES DE ENTREGA, ROGAMOS INDIQUEN LOS SIGUIENTES DATOS CUANDO PASE PEDIDOS DE RECAMBIO:

- MODELO DE MAQUINA
- NO. DE SERIE DE LA MAQUINA
- NO. DE SERIE DEL MOTOR (EN PIEZAS PARA MOTOR)
- REFERENCIA DEL RECAMBIO
- CANTIDAD PEDIDA

E 3089-0606

Position Ref.No. Repère Posizione Posicion	Menge Quantity Quantité Quantità Cantidad	Teile-Nr. Part-No. No. Référence Nr. d'Ordine No. Referenzia	Hinweis Hints Indications Indicazione Indicaciones	Position Ref. No. Repère Posizione Posicion	Menge Quantity Quantité Quantità Cantidad	Teile-Nr. Part-No. No. Référence Nr. d'Ordine No. Referenzia	Hinweis Hints Indications Indicazione Indicaciones
1	1	10016757					
2	1	25030002	DIN908-M14x1,5				
3	4	20026485					
4	2	10016758					
5	6	20029009	VSK 20				
6	6	25038032	DIN933-M20x40				
7	1	20013299					
8	1	30047368					
9	9	20029021	SKB 8				
10	9	25038008	DIN933-M8x25				
11	2	11000288					
12	2	11000289					
13	12	20025158					
14	12	25038022	DIN933-M12x40				
15	4	20004059					
16	8	25049019	DIN7349-17x40x6				
17	8	20029002	VSK 16				
18	4	25031006	DIN934-M16				
19	4	25038024	DIN933-M16x30				
20	4	10016367					
21	4	20025158					
22	4	10001423					
23	4	20005018					
24	1	10001447	Lombardini				
24	1	10001452	Honda				
25	8	20029026					
26	6	25045041	DIN912-M12x140-12.9				
27	2	25045042	DIN912-M12x170-12.9				

Lombardini
Honda

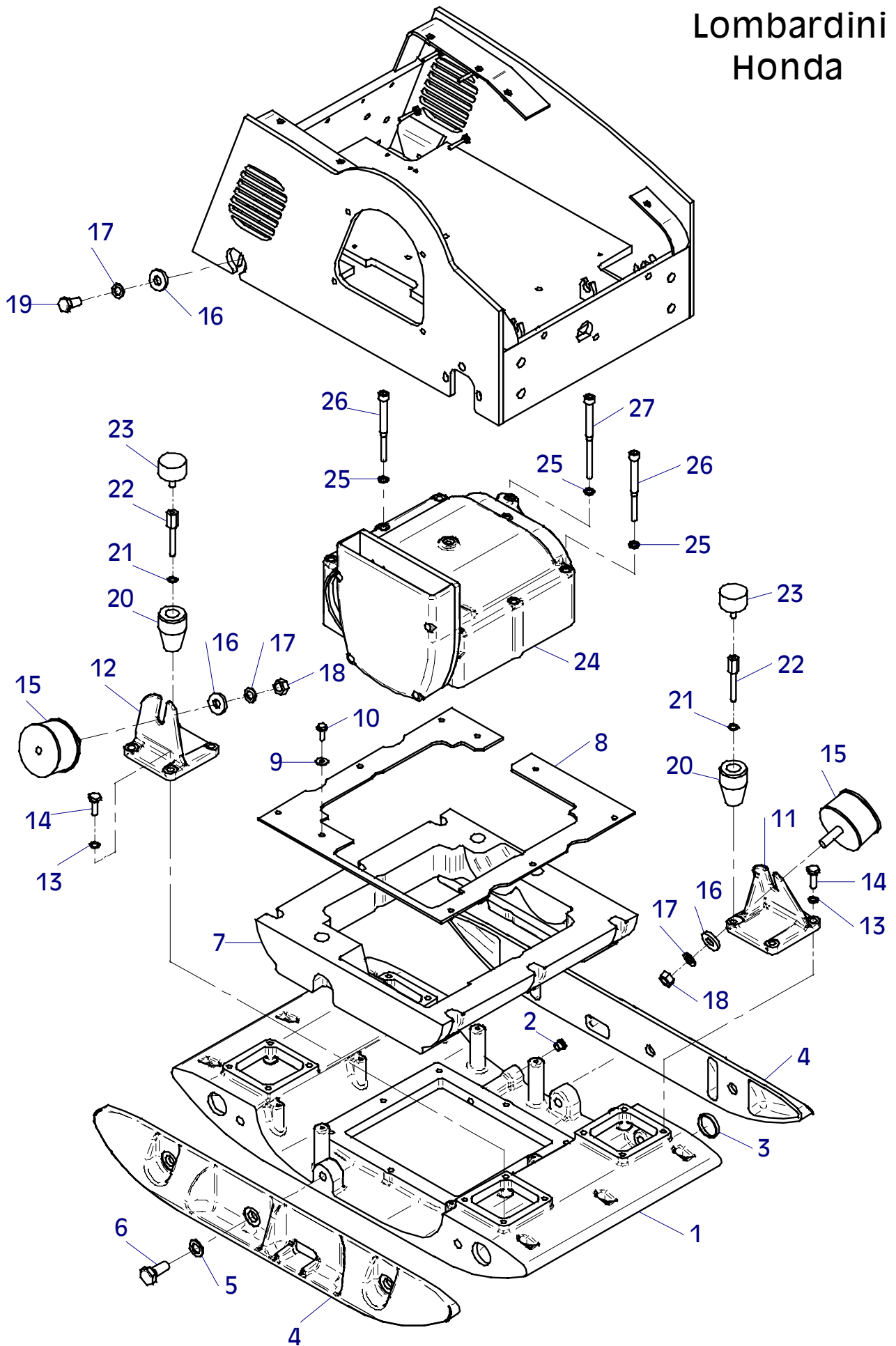

E 3089-0606

E 3204-0606

Position Ref.No. Repère Posizione Posicion	Menge Quantity Quantité Quantità Cantidad	Teile-Nr. Part-No. No. Référence Nr. d'Ordine No. Referenzia	Hinweis Hints Indications Indicazione Indicaciones	Position Ref. No. Repère Posizione Posicion	Menge Quantity Quantité Quantità Cantidad	Teile-Nr. Part-No. No. Référence Nr. d'Ordine No. Referenzia	Hinweis Hints Indications Indicazione Indicaciones
1	1	10016757		31	2	25044047	DIN912-M12x50
2	1	25030002	DIN908-M14x1,5	32	2	10017304	
3	4	20026485		33	2	10017300	
4	2	10016758		34	2	20026576	
5	6	20029009	VSK 20				
6	6	25038032	DIN933-M20x40				
7	1	20013299					
8	1	30047368					
9	9	20029021	SKB 8				
10	9	25038008	DIN933-M8x25				
11	2	11000288					
12	2	11000289					
13	12	20025158					
14	12	25038022	DIN933-M12x40				
15	4	20004059					
16	8	25049019	DIN7349-17x40x6				
17	8	20029002	VSK 16				
18	4	25031006	DIN934-M16				
19	4	25038024	DIN933-M16x30				
20	2	10016367					
21	2	20025158					
22	2	10001423					
23	2	20005018					
24	1	10001447					
25	8	20029026					
26	6	25045041	DIN912-M12x140-12.9				
27	2	25045042	DIN912-M12x170-12.9				
29	2	10017360					
30	2	20025158					

Lombardini CCD

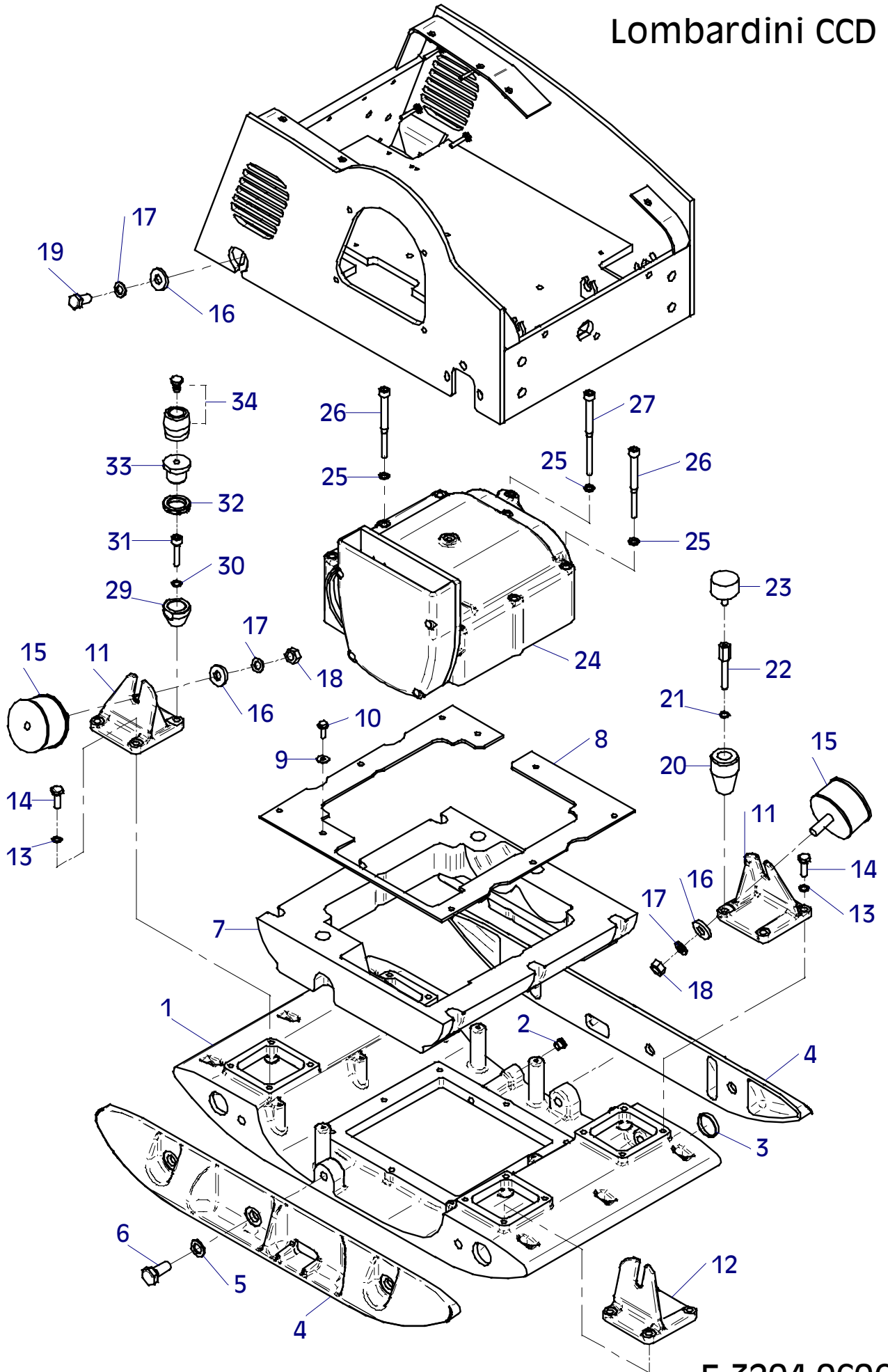

E 3204-0606

E 3090-0905

Position Ref.No. Repère Posizione Posicion	Menge Quantity Quantité Quantita Cantidad	Teile-Nr. Part-No. No. Référence Nr. d'Ordine No. Referenzia	Hinweis Hints Indications Indicazione Indicaciones	Position Ref. No. Repère Posizione Posicion	Menge Quantity Quantité Quantita Cantidad	Teile-Nr. Part-No. No. Référence Nr. d'Ordine No. Referenzia	Hinweis Hints Indications Indicazione Indicaciones
1	1	10016164		29	1	10017035	Honda
2	1	25038042	DIN933-M12x16	30	1	10016388	
3	1	25008011	DIN7603-12x18x1,5	31	1	10007370	
4	1	10016165		32	1	20029001	VSK 10
5	4	25044010	DIN912-M8x65	33	1	10016382	
6	4	20029011	VSKZ 8	34	2	25001701	
7	2	10016167		35	1	10016910	
8	8	25044005	DIN912-M8x20	36	2	25025157	
9	8	20029011	VSKZ 8	37	2	25045035	DIN912-M12x50-10.9
10	2	20013290		38	1	10016386	
11	1	10016166		39	2	25001702	
12	4	25044005	DIN912-M8x20	40	1	10016171	
13	4	20029011	VSKZ 8	41	1	10016383	
14	1	25017201		42	1	10016385	
15	1	20013290		43	1	25029015	DIN3625-8x80
16	1	10016168		44	1	25028004	DIN915-M10x25
17	4	25044005	DIN912-M8x20	45	1	25035018	DIN472-I32
18	4	20029011	VSKZ 8	46	1	25001703	
19	1	25030016	DIN910-M10x1	47	1	25034025	DIN471-A15x1
20	1	25008012	DIN7603-10x16x1	48	1	10016387	
21	1	20013290		49	1	20013275	
22	1	10016379		50	1	25030001	DIN908-M10x1
23	2	25001701		51	1	20020562	
24	1	10016170		52	0	25026027	DIN988-PS-80x100x0,1
25	1	25015076		53	0	25026028	DIN988-PS-80x100x0,2
26	2	10016909		54	0	25026029	DIN988-PS-80x100x0,5
27	2	25025157		55	1	20013305	
28	2	25045035	DIN912-M12x50-10.9				
29	1	10016911	Lombardini				

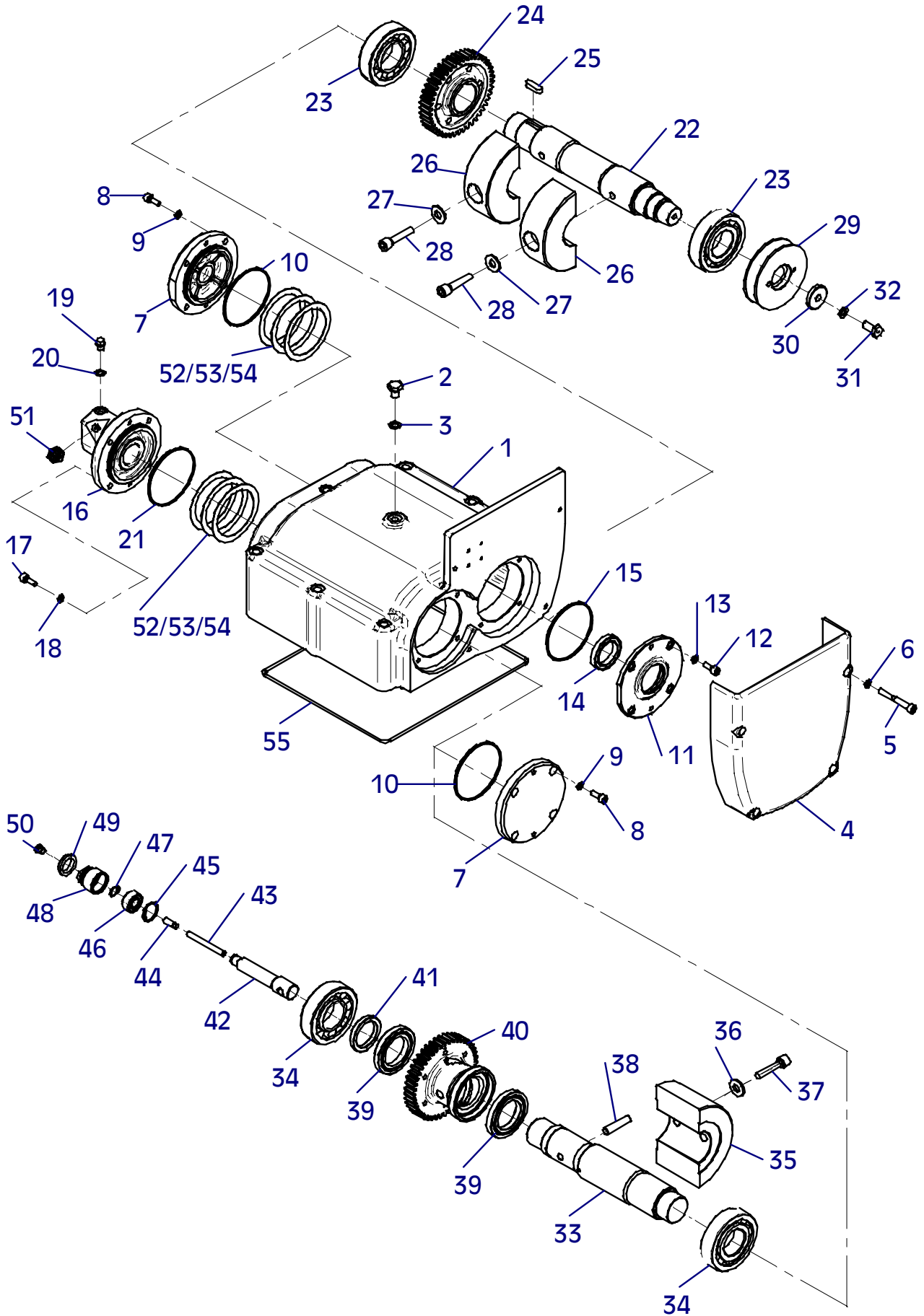

E 3090-0905

E 3205-0707

Position Ref.No. Repère Posizione Posicion	Menge Quantity Quantité Cantidad	Teile-Nr. Part-No. No. Référence Nr. d'Ordine No. Referenzia	Hinweis Hints Indications Indicazione Indicaciones	Position Ref. No. Repère Posizione Posicion	Menge Quantity Quantité Cantidad	Teile-Nr. Part-No. No. Référence Nr. d'Ordine No. Referenzia	Hinweis Hints Indications Indicazione Indicaciones
1	1	11000008		31	2	25031012	DIN985-M6
2	2	10017392		32	2	10015839	
3	4	25038014	DIN933-M10x25	33	2	20007077	
4	4	20029033	SKM 10	34	2	25040028	DIN931-M8x45
5	2	11000043		35	2	25048002	DIN125-A8,4
6	1	30047385		36	1	11000172	
7	4	25038007	DIN933-M8x20	37	8	25044045	DIN912-M16x40-10.9
8	4	20029003	VSK 8	38	8	20029029	
9	1	10016839		39	4	20026565	
10	5	25038015	DIN933-M10x30	40	1	10017337	
11	5	20029033	SKM 10	41	2	21000031	
12	2	30047379		42	2	11000148	
13	8	10016855		43	1	11000030	
14	8	20029003	VSK 8	44	1	20005001	
15	8	25031003	DIN934-M8	45	1	25031012	DIN985-M6
16	1	11000431		46	1	21000004	DIN71803-M6
17	8	25038013	DIN933-M10x20	47	1	25031012	DIN985-M6
18	8	20029033	SKM 10	49	1	25044037	DIN912-M10x55
19	1	11000484		50	1	25048003	DIN125-A10,5
20	4	25047020	DIN7991-M6x16	51	1	20029001	VSK 10
21	4	20029007	VSK 6	52	1	25031004	DIN934-M10
22	4	25031002	DIN934-M6	53	1	20026481	
23	1	10008354		54	2	25025191	DIN80705-M20x1,5
24	1	20026544		55	2	20025019	
25	1	25044063	DIN912-M8x35	56	2	25048001	DIN125-A6,4
26	1	20026545		57	2	25040022	DIN931-M16x70
27	1	20022002	Tensilock M8	58	2	25031017	DIN985-M16
28	1	11000015					
29	2	25033030	ISO7380-M6x20-10.9				
30	2	25049033	DIN9021-6,4/18x1,6				

Lombardini

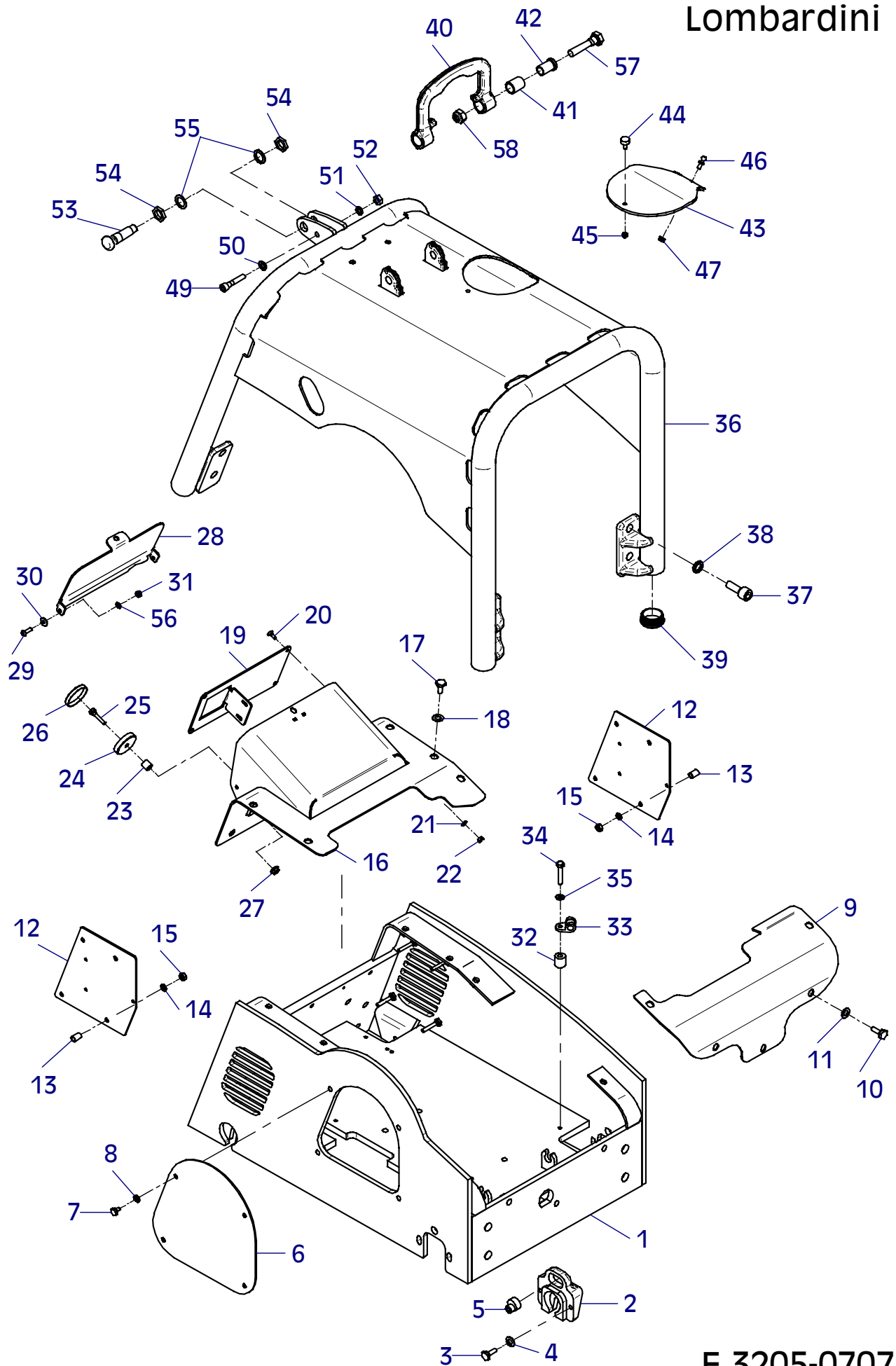

E 3205-0707

E 3206-0707

Position Ref.No. Repère Posizione Posicion	Menge Quantity Quantité Quantita Cantidad	Teile-Nr. Part-No. No. Référence Nr. d'Ordine No. Referenzia	Hinweis Hints Indications Indicazione Indicaciones	Position Ref. No. Repère Posizione Posicion	Menge Quantity Quantité Quantita Cantidad	Teile-Nr. Part-No. No. Référence Nr. d'Ordine No. Referenzia	Hinweis Hints Indications Indicazione Indicaciones
1	1	11000008		36	8	25044045	DIN912-M16x40-10.9
2	2	10017392		37	8	20029029	
3	4	25038014	DIN933-M10x25	38	4	20026565	
4	4	20029033	SKM 10	39	1	10017337	
5	2	11000043		40	2	21000031	
6	1	30047385		41	2	11000148	
7	4	25038007	DIN933-M8x20	42	1	11000030	
8	4	20029003	VSK 8	43	1	20005001	
9	2	10017359		44	1	25031012	DIN985-M6
10	7	25038006	DIN933-M8x16	45	1	21000004	DIN71803-M6
11	8	20029031	SKM 8	46	1	25031012	DIN985-M6
12	1	10016839		48	1	25044037	DIN912-M10x55
13	5	25038015	DIN933-M10x30	49	1	25048003	DIN125-A10,5
14	5	20029033	SKM 10	50	1	20029001	VSK 10
15	2	30047379		51	1	25031004	DIN934-M10
16	8	10016855		52	1	20026481	
17	8	20029003	VSK 8	53	2	25025191	DIN80705-M20x1,5
18	8	25031003	DIN934-M8	54	2	20025019	
19	1	11000431		55	2	25048001	DIN125-A6,4
20	8	25038013	DIN933-M10x20	56	2	25025092	DIN1587-M8
21	8	20029033	SKM 10	57	1	25038073	DIN933-M8x12
22	1	10008354		58	2	25040022	DIN931-M16x70
23	1	20026544		59	2	25031017	DIN985-M16
24	1	25044063	DIN912-M8x35	60	1	11000436	
25	1	20026545		61	4	25047020	DIN7991-M6x16
26	1	20022002	Tensilock M8	62	4	20029007	VSK 6
27	1	11000015		63	4	25031002	DIN934-M6
28	2	25033030	ISO7380-M6x20-10.9				
29	2	25049033	DIN9021-6,4/18x1,6				
30	2	25031012	DIN985-M6				
31	2	10015839					
32	2	20007077					
33	2	25040028	DIN931-M8x45				
34	2	25048002					
35	1	11000172					

Lombardini CCD

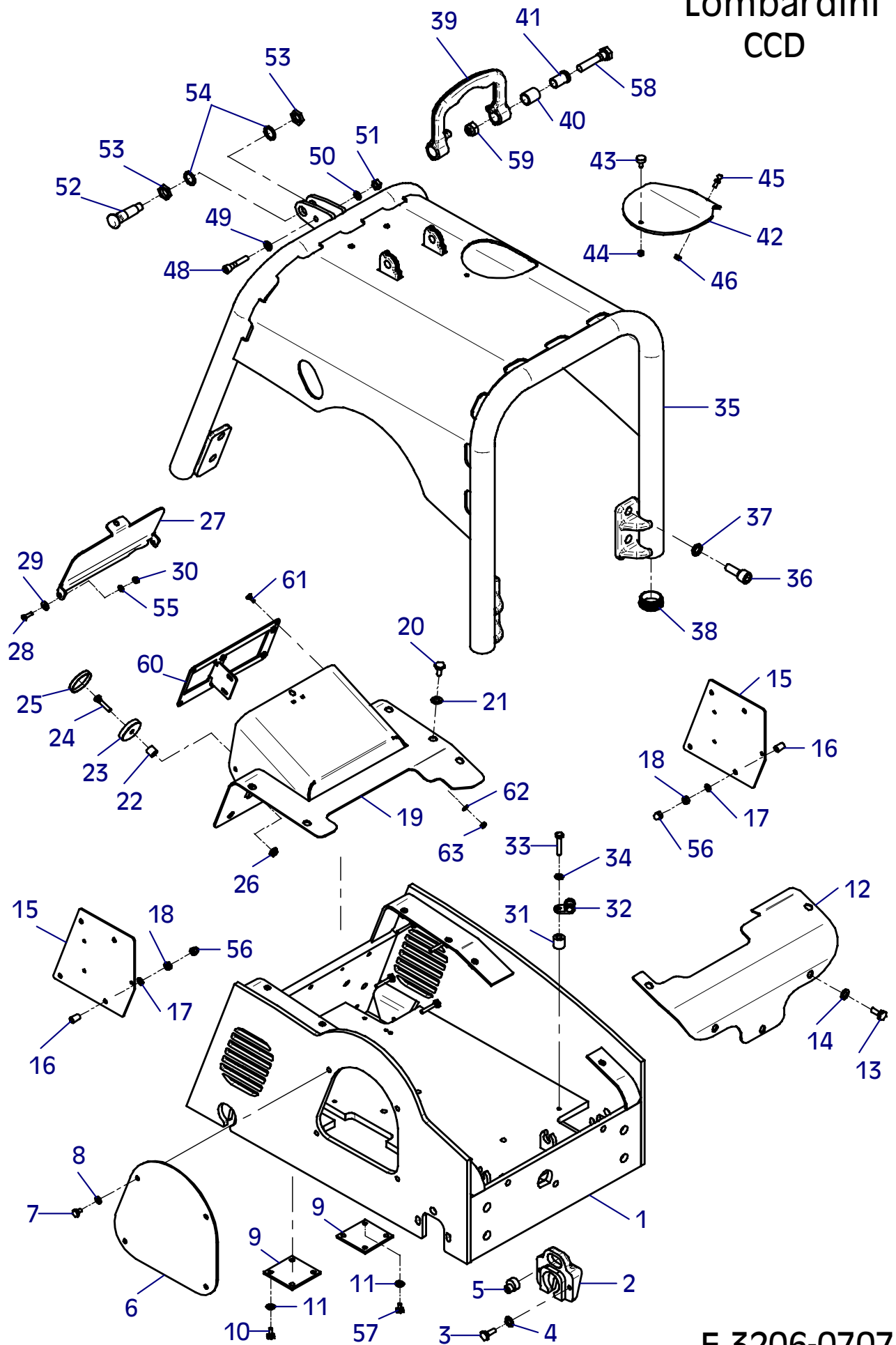

E 3206-0707

E 3208-0707

Position Ref.No. Repère Posizione Posicion	Menge Quantity Quantité Quantita Cantidad	Teile-Nr. Part-No. No. Référence Nr. d'Ordine No. Referenzia	Hinweis Hints Indications Indicazione Indicaciones	Position Ref. No. Repère Posizione Posicion	Menge Quantity Quantité Quantita Cantidad	Teile-Nr. Part-No. No. Référence Nr. d'Ordine No. Referenzia	Hinweis Hints Indications Indicazione Indicaciones
1	1	21000051		29	1	10022625	
1	1	21000054	EPA	30	1	20007086	
1	1	21000310	MSM	34	1	20029011	VSKZ 8
2	3	25040012	DIN931-M10x55	35	1	25038007	DIN933-M8x20
3	1	25040014	DIN931-M10x65	36	1	20025122	
4	3	25049020	DIN7349-10,5	37	1	25049026	DIN7349-8,4
5	2	11000316		38	1	20022002	Tensilock M8
6	3	20022003	Tensilock M10	39	1	20007226	
7	1	25049020	DIN7349-10,5	40	1	25038002	DIN933-M6x16
8	1	20022003	Tensilock M10				
9	2	25048003	DIN125-A10,5				
10	1	20022003	Tensilock M10				
11	1	20025702					
12	1	25008016	DIN7603-14x18x1,5				
13	1	20025704					
14	1	20025434					
15	1	20026559					
16	1	20007024					
17	1	11000176					
18	4	25042006	3/8"-16UNC				
19	4	20029001	VSK 10				
20	1	20026578	0,73 m				
21	2	20026578	0,081 m				
22	1	20002091					
23	1	25002175					
24	1	21000043	DIN912-M8x75-12.9				
25	1	11000146					
26	1	11000179					
27	1	25038006	DIN933-M8x16				
28	1	20029031	SKM 8				

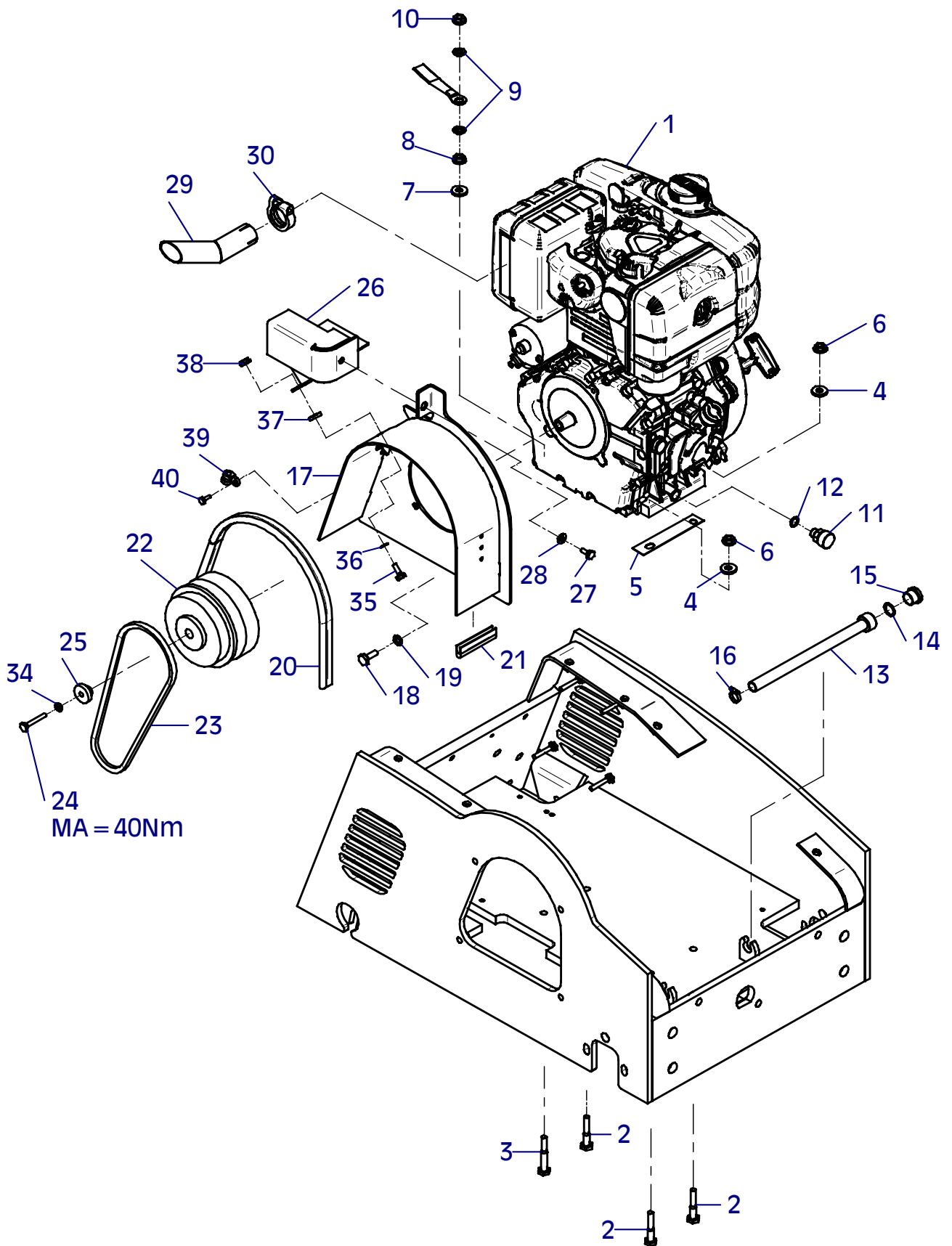

E 3094-0606

Position Ref.No. Repère Posizione Posicion	Menge Quantity Quantité Quantita Cantidad	Teile-Nr. Part-No. No. Référence Nr. d'Ordine No. Referenzia	Hinweis Hints Indications Indicazione Indicaciones	Position Ref. No. Repère Posizione Posicion	Menge Quantity Quantité Quantita Cantidad	Teile-Nr. Part-No. No. Référence Nr. d'Ordine No. Referenzia	Hinweis Hints Indications Indicazione Indicaciones
1	1	20002091					
2	2	20002268					
3	2	20002289					
4	2	21000117					
5	3	21000153					

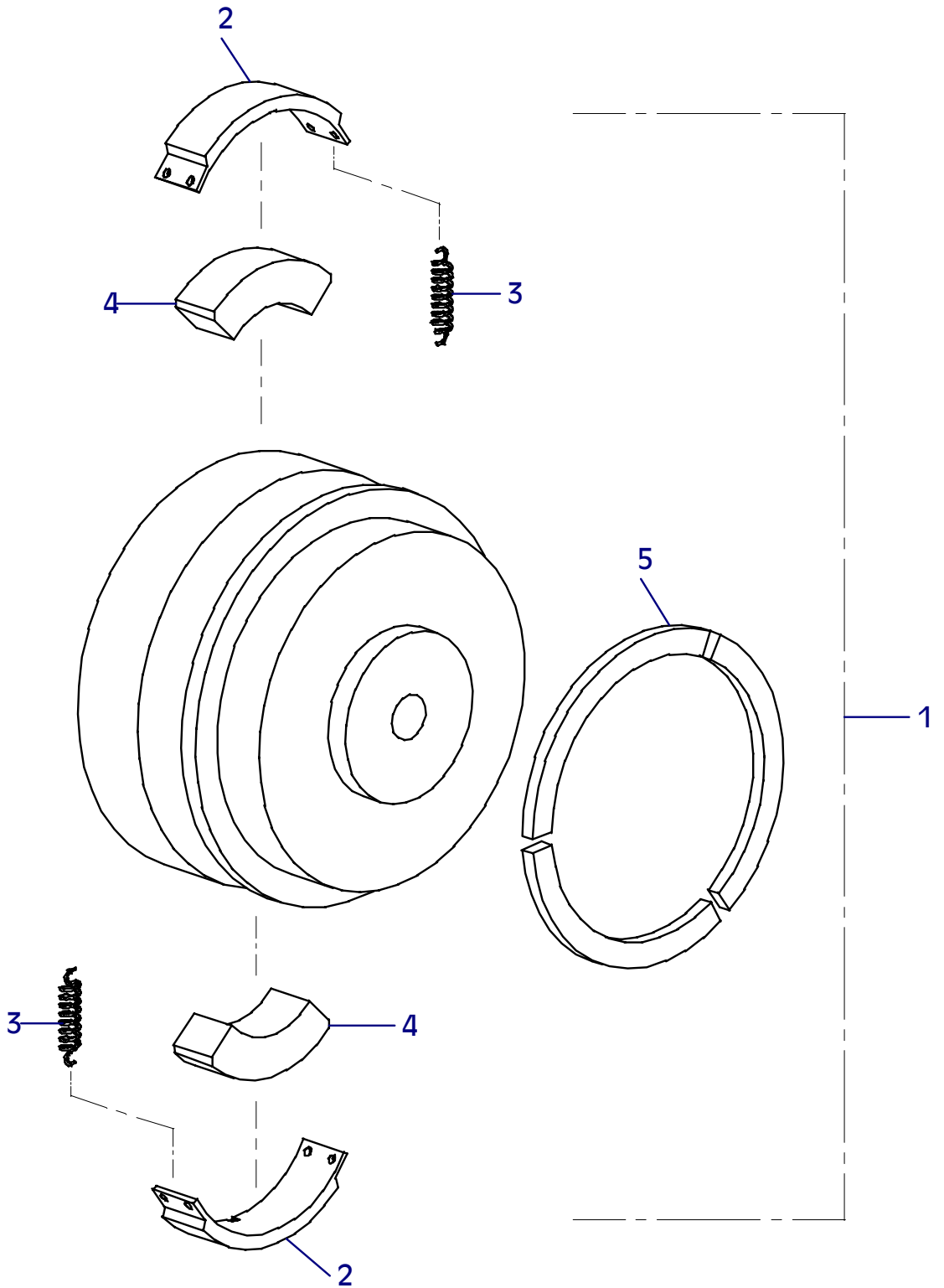

E 3277-0707

Position Ref.No. Repère Posizione Posicion	Menge Quantity Quantité Quantita Cantidad	Teile-Nr. Part-No. No. Référence Nr. d'Ordine No. Referenzia	Hinweis Hints Indications Indicazione Indicaciones	Position Ref. No. Repère Posizione Posicion	Menge Quantity Quantité Quantita Cantidad	Teile-Nr. Part-No. No. Référence Nr. d'Ordine No. Referenzia	Hinweis Hints Indications Indicazione Indicaciones
1	1	11000493					
2	4	21000325	DIN7981-C3,9x9,5				
4	1	11000487					
5	1	20007106					
6	1	21000272	CR 6				
6	1	21000273	CR 7				
7	1	11000490					
8	2	21000275	ISO7380-M10x30				
9	2	20025287					
10	1	11000491					
11	2	21000281					
12	4	20022002	Tensilock M8				
13	1	11000486					
14	1	11000488					
15	1	11000489					
16	1	21000268	DIN1481-4x40				
17	1	21000244					
18	1	11000556					
19	1	21000270					
20	1	20013279					
21	1	25031035	DIN986-M4				
22	1	21000274					

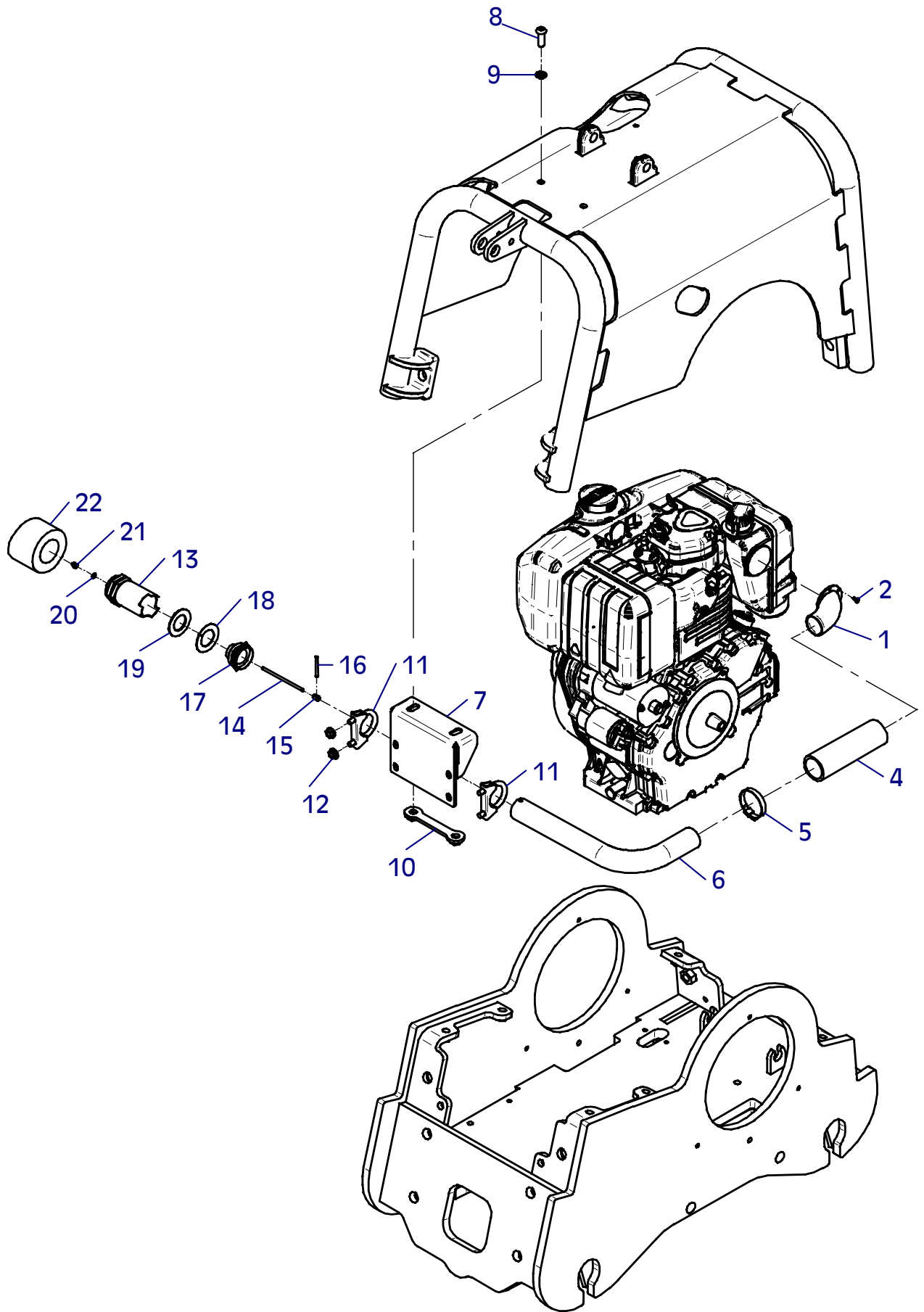

E 3277-0707

E 3211-0707

Position Ref.No. Repère Posizione Posicion	Menge Quantity Quantité Quantita Cantidad	Teile-Nr. Part-No. No. Référence Nr. d'Ordine No. Referenzia	Hinweis Hints Indications Indicazione Indicaciones	Position Ref. No. Repère Posizione Posicion	Menge Quantity Quantité Quantita Cantidad	Teile-Nr. Part-No. No. Référence Nr. d'Ordine No. Referenzia	Hinweis Hints Indications Indicazione Indicaciones
1	1	10003989					
2	2	25038007	DIN933-M8x20				
3	2	20029003	VSK 8				
4	1	20031502					
5	2	10016930					
6	2	10015530					
7	1	20016289	0,4 m				
8	1	10001433					
9	1	20025566					
10	1	30025028	0,19 m				
11	1	10015631					
12	2	25020028	DIN976-M8x200				
13	10	25031003	DIN934-M8				
14	4	20029003	VSK 8				
15	1	10001469					
16	2	25038002	DIN933-M6x16				
17	2	20029020	SKB 6				
18	1	11000054					
19	1	40080599					
20	1	20031532					
21	2	25038038	DIN933-M5x16				
22	2	25048017	DIN125-A5,3				
23	2	25031023	DIN985-M5				
24	1	20031541					

Lombardini

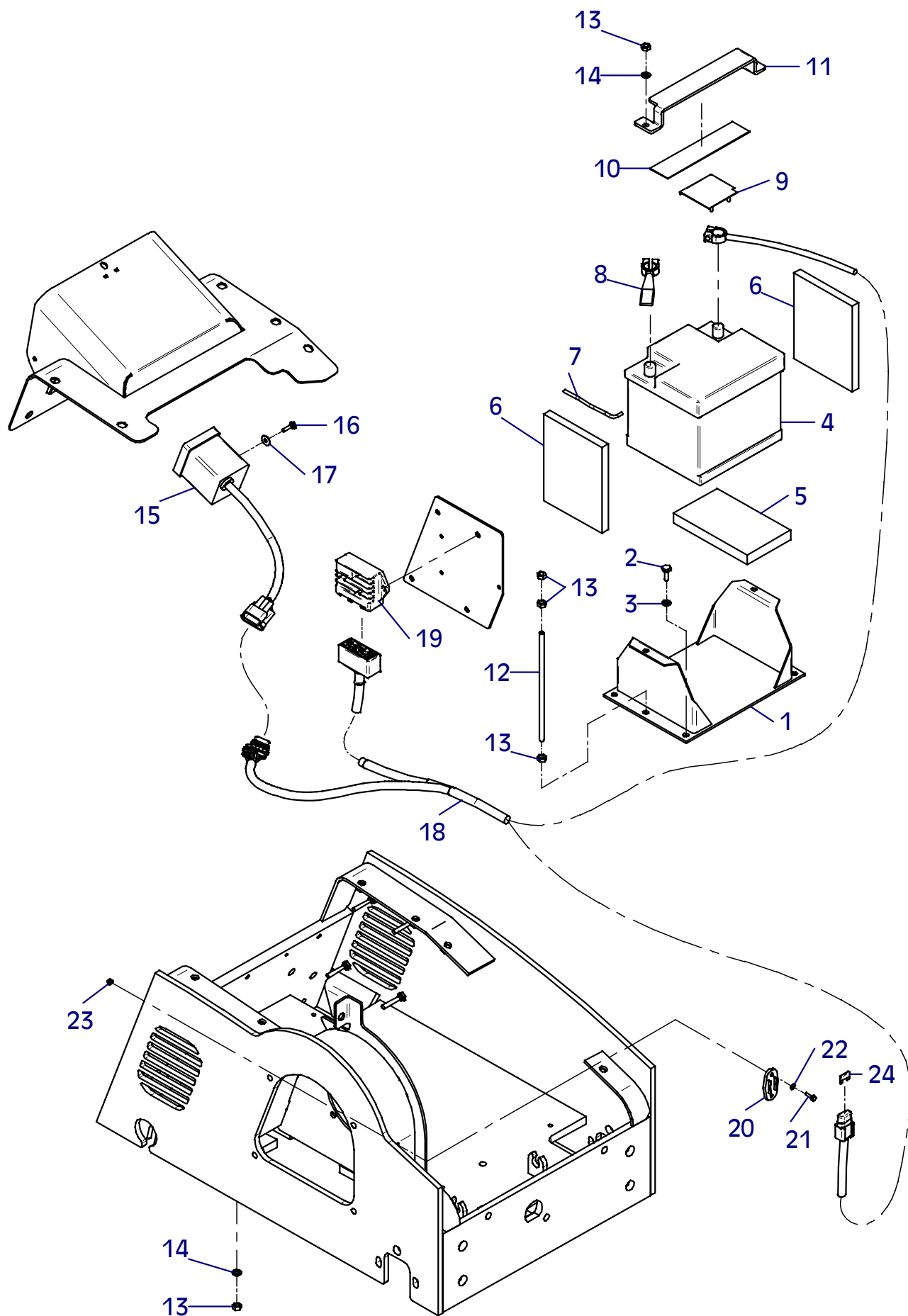

E 3211-0707

E 3212-0707

Position Ref.No. Repère Posizione Posicion	Menge Quantity Quantité Quantita Cantidad	Teile-Nr. Part-No. No. Référence Nr. d'Ordine No. Referenzia	Hinweis Hints Indications Indicazione Indicaciones	Position Ref. No. Repère Posizione Posicion	Menge Quantity Quantité Quantita Cantidad	Teile-Nr. Part-No. No. Référence Nr. d'Ordine No. Referenzia	Hinweis Hints Indications Indicazione Indicaciones
1	1	10003989		32	1	25044074	DIN912-M6x12
2	1	25038007	DIN933-M8x20	33	1	20029015	VSKZ 6
3	2	20029003	VSK 8	34	1	20026574	
4	1	20031502		35	4	25044080	DIN912-M5x25
5	2	10016930		36	4	20029006	VSK 5
6	2	10015530		37	1	25038073	DIN933-M8x12
7	1	20016289	0,4 m				
8	1	10001433					
9	1	20025566					
10	1	30025028	0,19 m				
11	1	10015631					
12	2	25020028	DIN976-M8x200				
13	10	25031003	DIN934-M8				
14	4	20029003	VSK 8				
15	1	10001469					
16	2	25038002	DIN933-M6x16				
17	2	20029020	SKB 6				
18	1	11000055					
19	1	40080599					
20	1	20031532					
21	2	25038038	DIN933-M5x16				
22	2	25048017	DIN125-A5,3				
23	2	25031023	DIN985-M5				
25	1	20031541					
26	1	20031579					
27	1	20026573					
28	4	25033029	ISO7380-M6x16-10.9				
29	3	20022001	Tensilock M6				
30	1	20025564					
31	1	20007069					

Lombardini CCD

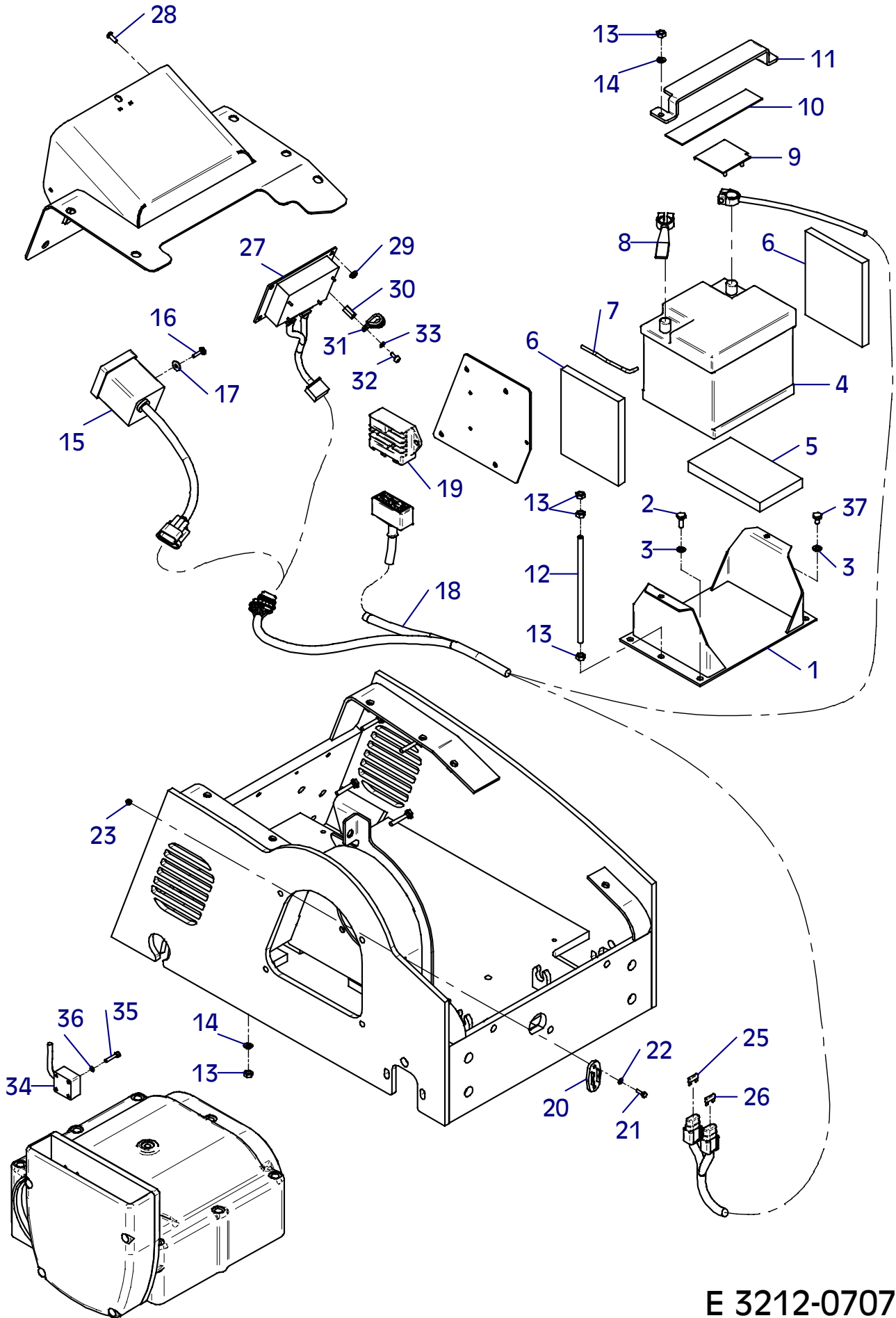

E 3212-0707

E 3207-0706

Position Ref.No. Repère Posizione Posicion	Menge Quantity Quantité Quantita Cantidad	Teile-Nr. Part-No. No. Référence Nr. d'Ordine No. Referenzia	Hinweis Hints Indications Indicazione Indicaciones	Position Ref. No. Repère Posizione Posicion	Menge Quantity Quantité Quantita Cantidad	Teile-Nr. Part-No. No. Référence Nr. d'Ordine No. Referenzia	Hinweis Hints Indications Indicazione Indicaciones
1	1	11000096		31	1	10017337	
2	2	10017392		32	2	21000031	
3	4	25038014	DIN933-M10x25	33	2	11000148	
4	4	20029033	SKM 10	34	1	11000078	
5	2	11000043		35	1	30047480	
6	1	30047521		36	2	25040022	DIN931-M16x70
7	3	25038007	DIN933-M8x20	37	3	25033030	ISO7380-M6x20-10.9
8	3	20029003	VSK 8	38	2	21000004	DIN71803-M6
9	1	10017014		39	2	25031012	DIN985-M6
10	7	25038015	DIN933-M10x30	40	1	11000079	
11	7	20029033	SKM 10	41	1	20005001	
12	1	11000185		42	2	25031017	DIN985-M16
13	7	25038013	DIN933-M10x20	43	1	25031012	DIN985-M6
14	7	20029033	SKM 10	44	1	21000004	DIN71803-M6
15				45	1	25031012	DIN985-M6
16				47	1	25044037	DIN912-M10x55
17				48	1	25048003	DIN125-A10,5
18				49	1	20029001	VSK 10
19	1	25049016	DIN440-R9	50	1	25031004	DIN934-M10
20	1	20007004		51	1	20026481	
21	1	25038008	DIN933-M8x25	52	2	25025191	DIN80705-M20x1,5
22	1	25048002	DIN125-A8,4	53	2	20025019	
23	1	20007007					
24	1	25038002	DIN933-M6x16				
25	1	40140041					
26	1	10001454					
27	1	11000182					
28	8	25044045	DIN912-M16x40-10.9				
29	8	20029029					
30	4	20026565					

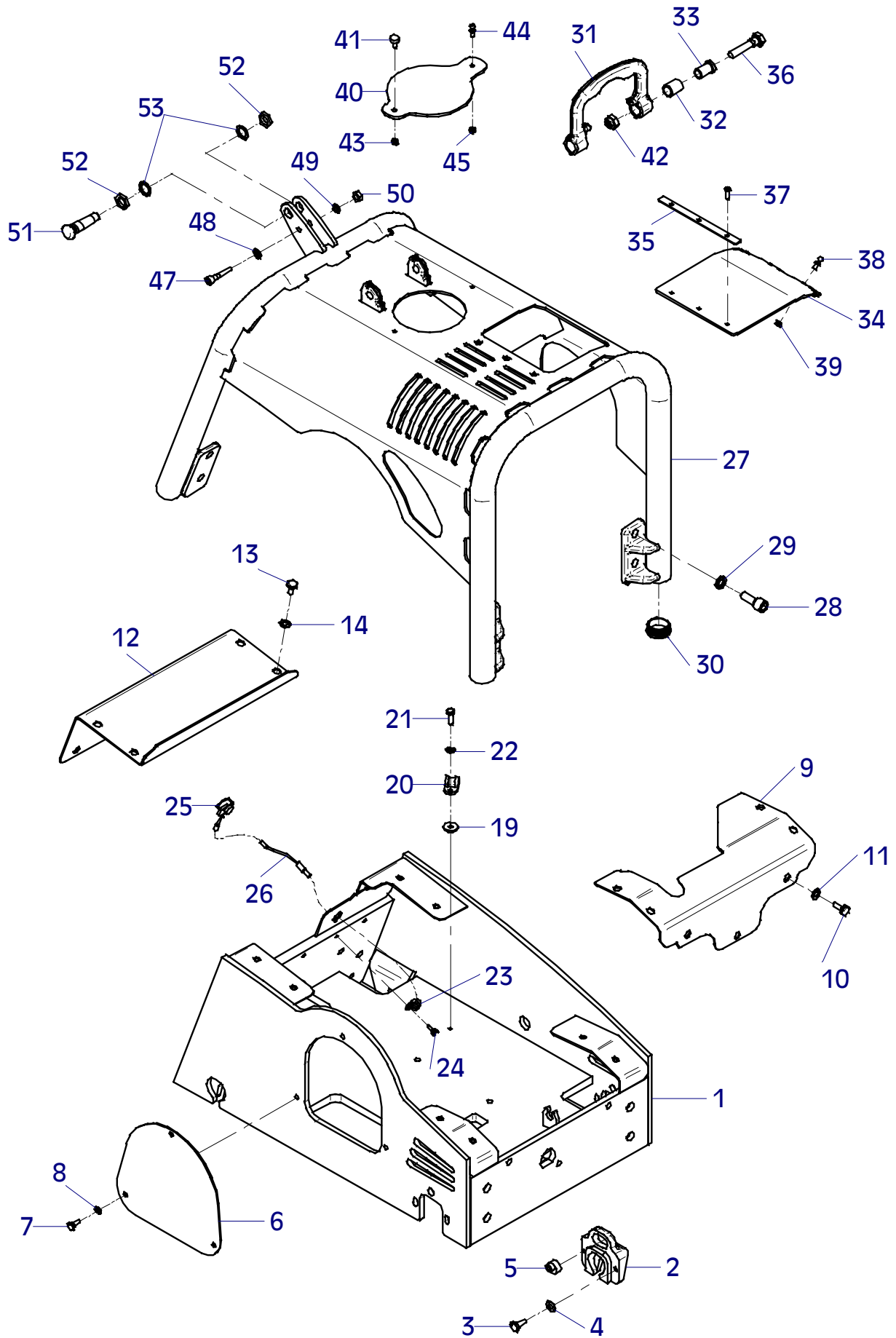

E 3209-0905

Position Ref.No. Repère Posizione Posicion	Menge Quantity Quantité Quantità Cantidad	Teile-Nr. Part-No. No. Référence Nr. d'Ordine No. Referenzia	Hinweis Hints Indications Indicazione Indicaciones	Position Ref. No. Repère Posizione Posicion	Menge Quantity Quantité Quantità Cantidad	Teile-Nr. Part-No. No. Référence Nr. d'Ordine No. Referenzia	Hinweis Hints Indications Indicazione Indicaciones
1	1	20001119		31	1	40001338	
2	4	25040014	DIN931-M10x65	32	1	20007007	
3	1	11000104		33	1	25038072	DIN933-M6x12
4	4	25049020	DIN7349-10,5	34	1	21000023	
5				35	1	30025076	0,695 m
6	4	20022003	Tensilock M10	36	2	20026578	0,081 m
7	1	25008011	DIN7603-12x18x1,5				
8	1	20026204					
9	1	20025704					
10	1	20025434					
11	1	20026559					
12	1	20007024					
13	1	11000099					
14	4	20025122					
15	4	25038006	DIN933-M8x16				
16	1	20002097					
17	1	25002175					
18	1	10017040					
19	1	20026475					
20	1	25040065	DIN931-M8x40				
21	1	20015175					
22	1	10017036					
23	1	25038002	DIN933-M6x16				
24	1	20029007	VSK 6				
25	1	25044065	DIN912-M6x25				
26	1	20029007	VSK 6				
27	1	25031002	DIN934-M6				
28	1	20007007					
29	1	25048001	DIN125-A6,4				
30	1	25038002	DIN933-M6x16				

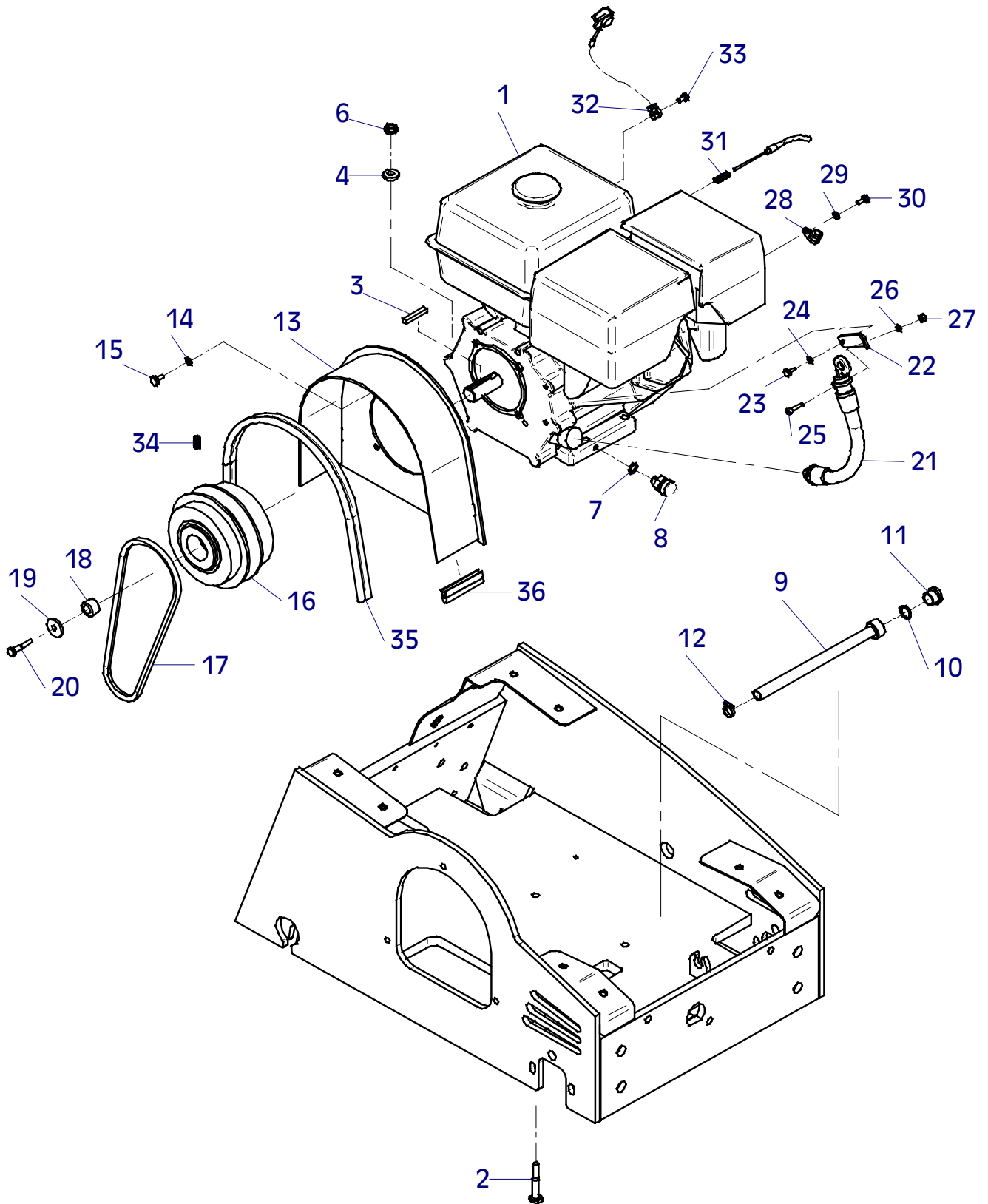

E 3096-0706

Position Ref.No. Repère Posizione Posicion	Menge Quantity Quantité Quantita Cantidad	Teile-Nr. Part-No. No. Référence Nr. d'Ordine No. Referenzia	Hinweis Hints Indications Indicazione Indicaciones	Position Ref. No. Repère Posizione Posicion	Menge Quantity Quantité Quantita Cantidad	Teile-Nr. Part-No. No. Référence Nr. d'Ordine No. Referenzia	Hinweis Hints Indications Indicazione Indicaciones
1	1	20002097					
2	2	20002268					
3	2	20002289					
4	2	21000117					
5	3	21000021					

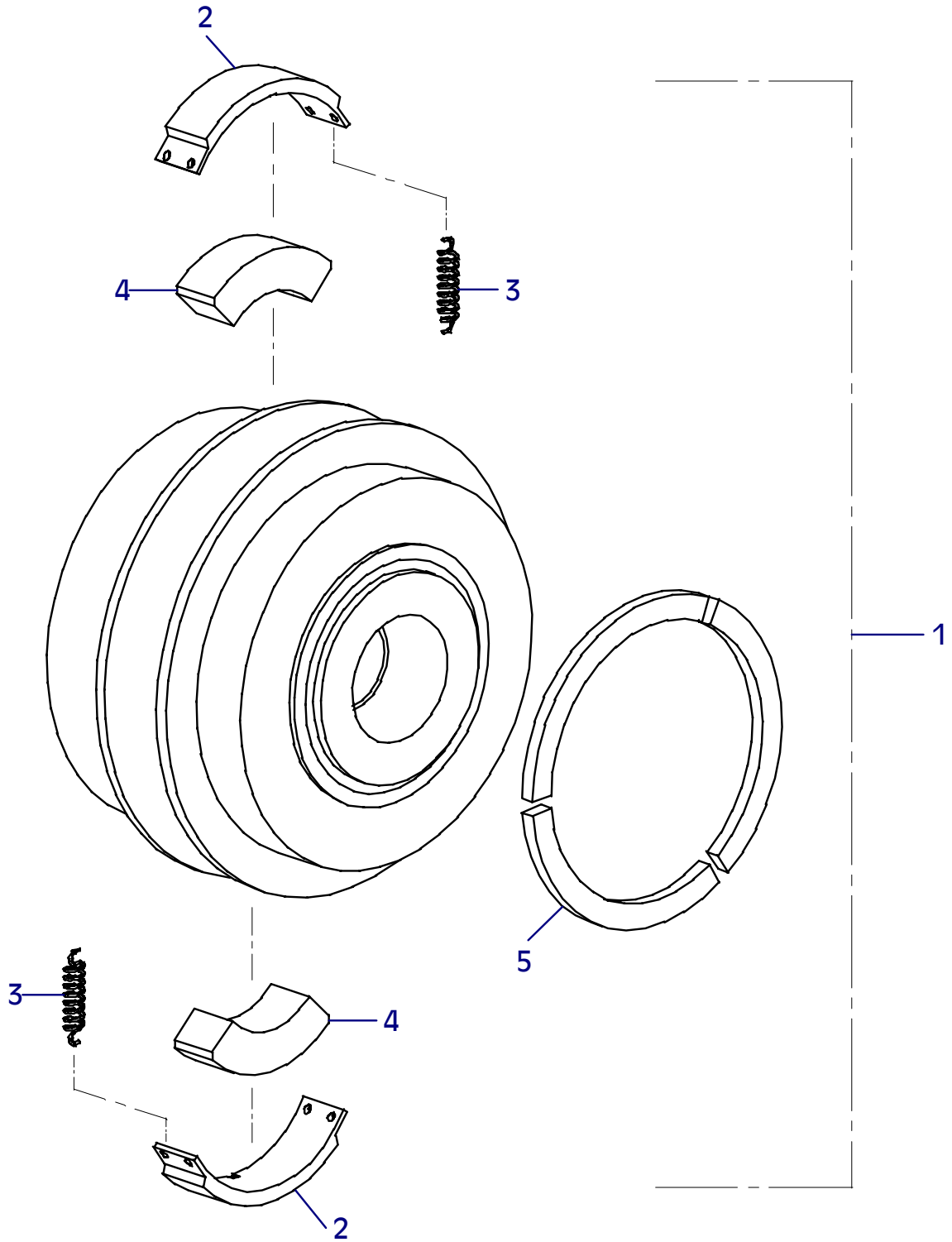

E 3096-0706

E 3210-0707

Position Ref.No. Repère Posizione Posicion	Menge Quantity Quantité Quantita Cantidad	Teile-Nr. Part-No. No. Référence Nr. d'Ordine No. Referenzia	Hinweis Hints Indications Indicazione Indicaciones	Position Ref. No. Repère Posizione Posicion	Menge Quantity Quantité Quantita Cantidad	Teile-Nr. Part-No. No. Référence Nr. d'Ordine No. Referenzia	Hinweis Hints Indications Indicazione Indicaciones
1	1	11000017		44	2	25044035	DIN912-M12x25
2	1	10022520		45	2	20029013	VSKZ 12
3	8	25038013	DIN933-M10x20	46	2	20025593	
4	8	20029033	SKM 10	47	1	11000038	
5	2	11000016		48	4	25038007	DIN933-M8x20
6	4	25044007	DIN912-M8x30	49	4	20029003	VSK 8
7	4	20029003	VSK 8	50	1	20008069	
8	4	25031003	DIN934-M8	51	1	10016307	
9	2	20026491		52	1	10016305	
10	2	20004016		53	2	20013285	
11	2	20026492		54	1	20013282	
12	2	10016291		55	1	20013286	
13	2	25040066	DIN931-M16x55	56	1	10016303	
14	2	20029002	VSK 16	57	1	10016308	
15	2	10017130		58	4	25044006	DIN912-M8x25
16	4	25044039	DIN912-M16x40	59	4	20025122	
17	4	20029029		60	2	25047022	DIN7991-M6x12
18	4	25038008	DIN933-M8x25	61	1	20020562	
19	4	20029003	VSK 8	62	1	10016938	Lombardini
20	1	11000037		62	1	10016100	Honda
21	1	25025305		63	1	20018157	Lombardini
22	1	21000033	DIN936-M20	63	1	20018160	Honda
23	1	21000008		64	1	20018082	
24	1	20007089		65	1	20018158	Lombardini
25	1	25040004	DIN931-M8x55	65	1	20018161	Honda
26	1	25048002	DIN125-A8,4	66	2	25038070	DIN933-M6x30
27	1	20016135	0,56 m	67	2	20029007	VSK 6
28	1	20007089		68	1	20016367	
29	1	25040027	DIN931-M8x35	69	1	20018143	
30	1	20029003	VSK 8	70	2	25038008	DIN933-M8x25
31	1	20016135	0,05 m	71	2	25048002	DIN125-A8,4
35	1	10016309					
36	1	25030018	DIN908-M26x1,5				
37	1	25008019	DIN7603-26x31x2				
38	1	20025764					
39	1	10017395					
40	2	10017398					
41	2	20013284					
42	2	21000009					
43	2	10017396					

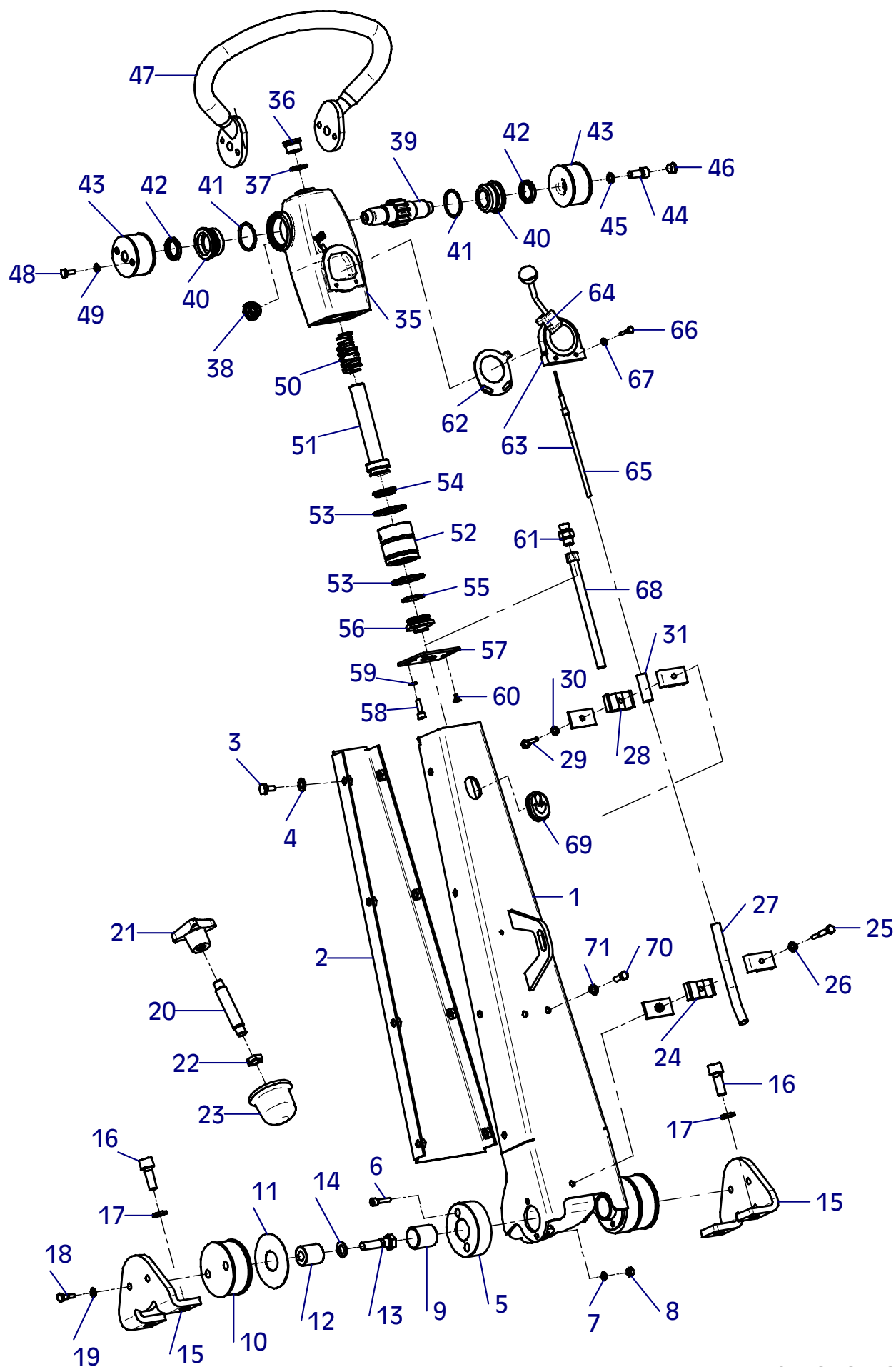

E 3210-0707

E 3099-0403

Position Ref.No. Repère Posizione Posicion	Menge Quantity Quantité Quantita Cantidad	Teile-Nr. Part-No. No. Référence Nr. d'Ordine No. Referenzia	Hinweis Hints Indications Indicazione Indicaciones	Position Ref. No. Repère Posizione Posicion	Menge Quantity Quantité Quantita Cantidad	Teile-Nr. Part-No. No. Référence Nr. d'Ordine No. Referenzia	Hinweis Hints Indications Indicazione Indicaciones
1	1	10016967					
2	2	10016968					
3	6	25040049	DIN931-M12x80				
4	6	20029004	VSK 12				
5	6	25031005	DIN934-M12				

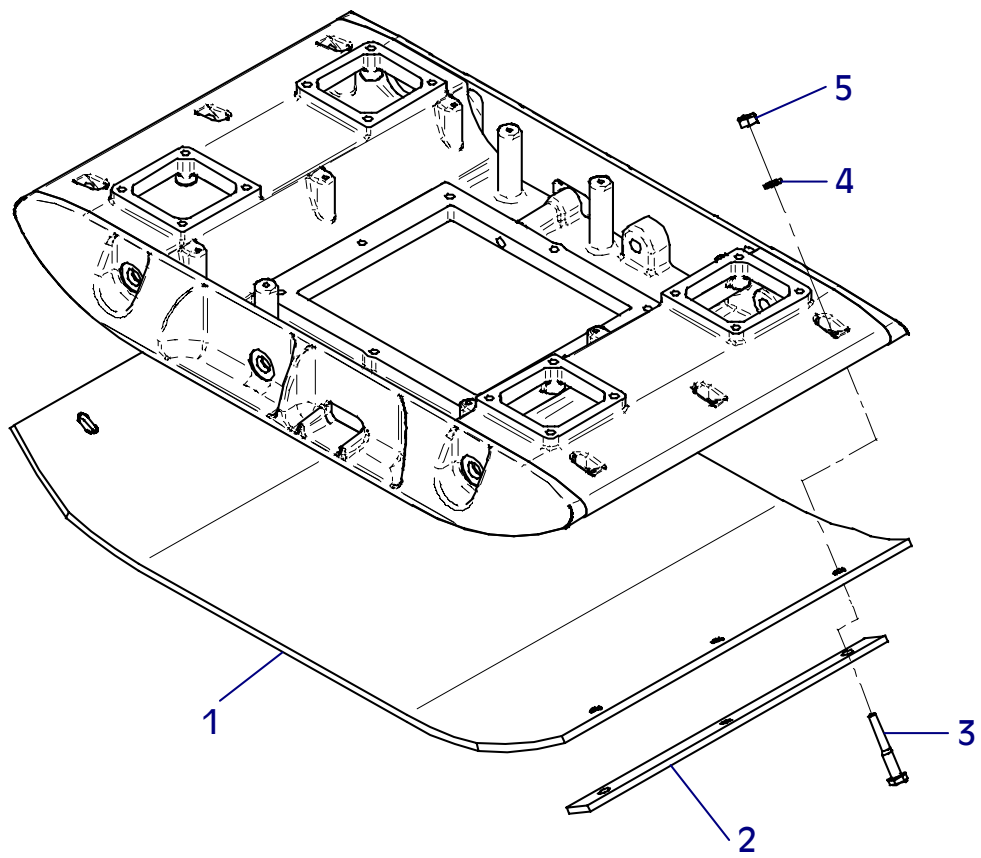

E 3099-0403

E 3100-0403

Position Ref.No. Repère Posizione Posicion	Menge Quantity Quantité Quantita Cantidad	Teile-Nr. Part-No. No. Référence Nr. d'Ordine No. Referenzia	Hinweis Hints Indications Indicazione Indicaciones	Position Ref. No. Repère Posizione Posicion	Menge Quantity Quantité Quantita Cantidad	Teile-Nr. Part-No. No. Référence Nr. d'Ordine No. Referenzia	Hinweis Hints Indications Indicazione Indicaciones
1	1	10016969					
2	2	10016970					
3	6	25040049	DIN931-M12x80				
4	6	20029004	VSK 12				
5	6	25031005	DIN934-M12				
6	2	10016759					
7	6	20029009	VSK 20				
8	2	25038032	DIN933-M20x40				
9	4	25038085	DIN933-M20x100-10.9				

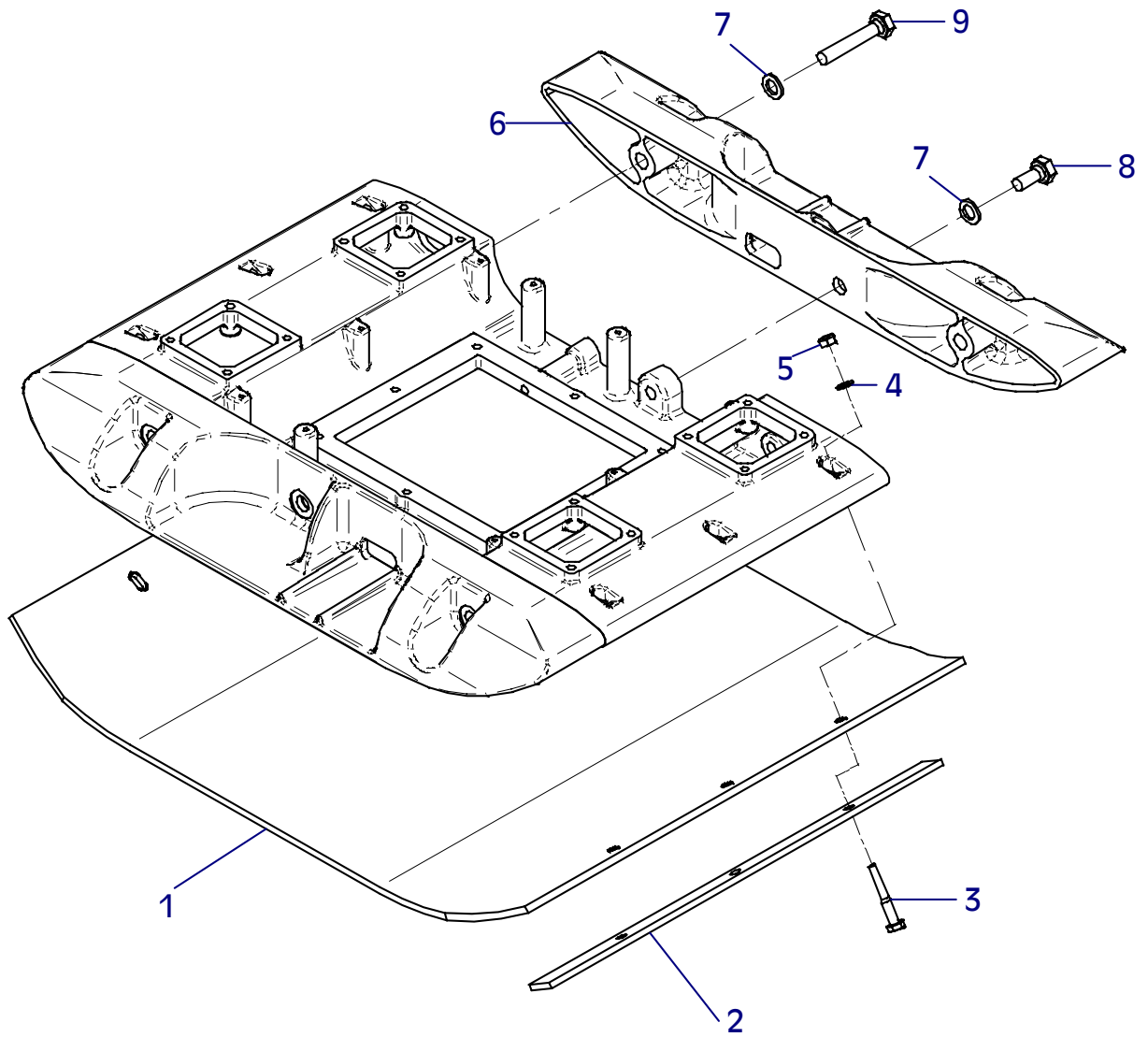

E 3100-0403

E 3101-0403

Position Ref.No. Repère Posizione Posicion	Menge Quantity Quantité Quantita Cantidad	Teile-Nr. Part-No. No. Référence Nr. d'Ordine No. Referenzia	Hinweis Hints Indications Indicazione Indicaciones	Position Ref. No. Repère Posizione Posicion	Menge Quantity Quantité Quantita Cantidad	Teile-Nr. Part-No. No. Référence Nr. d'Ordine No. Referenzia	Hinweis Hints Indications Indicazione Indicaciones
1	2	10016971					
2	6	20029009	VSK 20				
3	6	25038032	DIN933-M20x40				

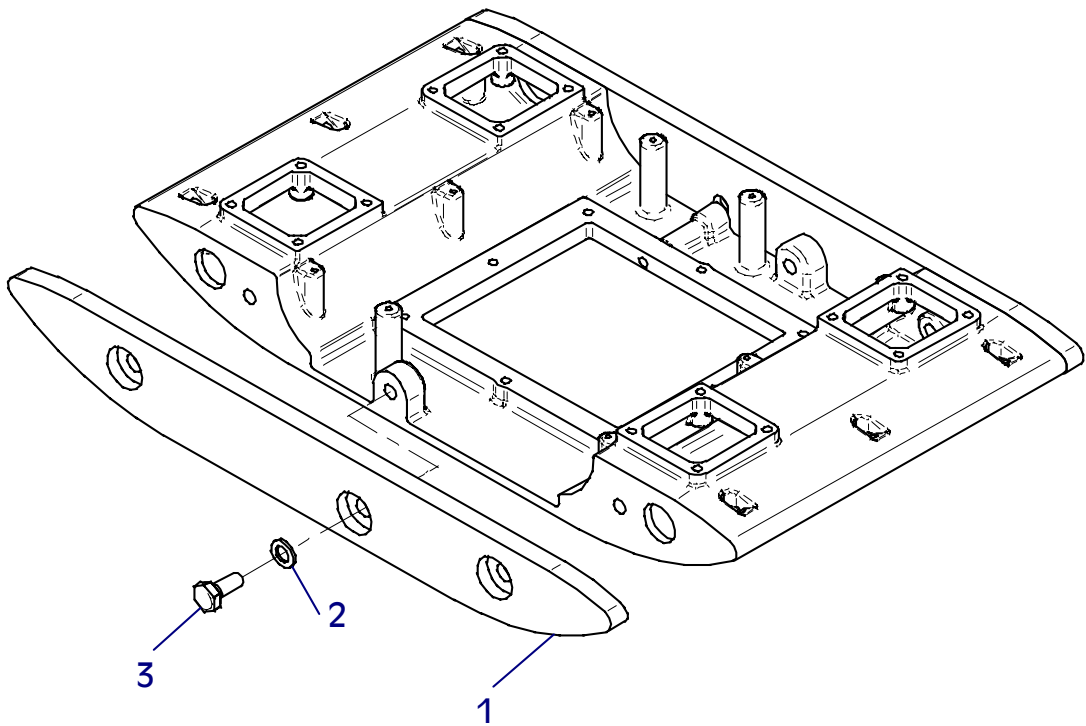

E 3101-0403

**Wenn Sie Fragen und Anregungen haben, oder sonstige Informationen benötigen,
wenden Sie sich bitte an eine der unten genannten Adressen:**

**For questions and further information refer to one of the
following addresses:**

<p>In Deutschland</p> <p>In Germany</p>	<p>WEBER Maschinenteknik GmbH Postfach 2153 57329 Bad Laasphe – Rückershausen</p> <p>Information / information: E-mail: info@webermt.de</p> <p>Ersatzteile / spare parts: E-mail: parts@webermt.de</p>	<p>Telefon / phone:</p> <p>Telefax / fax:</p> <p>Telefax / fax:</p>	<p>+49 (0) 2754 / 3980 Zentrale / switchboard</p> <p>+49 (0) 2754 / 398101 Zentrale / switchboard</p> <p>+49 (0) 2754 / 398102 Ersatzteile / spare parts direct dial</p>
<p>In Holland</p> <p>In Netherlands</p>	<p>WEBER Maschinenteknik B.V. Graafschap Hornelaan 159 6001 AC Weert</p> <p>E-mail: info@webermt.nl</p>	<p>Telefon / phone:</p> <p>Telefax / fax:</p>	<p>+31 (0) 495 / 530215</p> <p>+31 (0) 495 / 541839</p>
<p>In Frankreich</p> <p>In France</p>	<p>WEBER Technologie S.A.R.L. 26, rue d'Arsonval 69680 Chassieu</p> <p>E-mail: france@webermt.com</p>	<p>Telefon / phone:</p> <p>Telefax / fax:</p>	<p>+33 (0) 472 / 791020</p> <p>+33 (0) 472 / 791021</p>
<p>In Polen</p> <p>In Poland</p>	<p>WEBER Maschinenteknik SP.ZO.O. ul. Grodziska 7 05-830 Stara Wies / Nadarzyn</p> <p>E-mail: info@webermt.com.pl</p>	<p>Telefon / phone:</p> <p>Telefax / fax:</p>	<p>+48 (0) 22 / 7397080 +48 (0) 22 / 7397081</p> <p>+48 (0) 22 / 7397082</p>
<p>In USA, Kanada</p> <p>In USA, Canada</p>	<p>WEBER Machine (USA), Inc. 40 Johnson Ave 112 Bangor, ME 04401 USA</p> <p>E-mail: usa@webermt.com</p>	<p>Telefon / phone:</p> <p>Telefax / fax:</p>	<p>+1 (0) 207 / 9474990</p> <p>+1 (0) 207 / 9475452</p>
<p>In Südamerika</p> <p>In South America</p>	<p>WEBER Maschinenteknik do Brasil Ltda. Rua Sete de Setembro, 275 93332-470 Novo Hamburgo, RS Brasil</p> <p>E-mail: webermt@webermt.com.br</p>	<p>Telefon / phone:</p> <p>Telefax / fax:</p>	<p>+55 (0) 51 / 5873044</p> <p>+55 (0) 51 / 5872271</p>

<http://www.webermt.com>

