



ERSATZTEILLISTE

SPARE PARTS LIST

**LISTE DES PIECES
DE RECHANGE**

LISTINO RICAMBI

LISTA DE RECAMBIOS

**WYKAZ CZESCI
ZAMIENNYCH**



CR 4
CR 4/65

011621-011626



Weber Maschinenteknik GmbH
Postfach 2153, 57329 Bad Laasphe-Rückershausen
Telefon 02754 / 398-0
Telefax (02754) 398-101 (Zentrale) u. 398-102 (Ersatzteile)

EG - KONFORMITÄTSERKLÄRUNG

EC DECLARATION OF CONFORMITY / DECLARATION DE CONFORMITE CE
DICHIARAZIONE CE DI CONFORMITA / DECLARACION CE DE CONFORMIDAD
EG-VERKLARING VAN OVEREENSTEMMING / EF-OVERENSSTEMMELSESERKAERING
DECLARACAO CE DE CONFORMIDADE / EG-FÖRSÄKRAN OM ÖVERENSSTÄMMELSE
DEKLARACJA ZGODNOŚCI

im Sinne der EG-Maschinenrichtlinie 98/37/EG und der EG Richtlinie 2000/14/EG - Geräuschemissionen

- I **Art / Category / Catégorie / Categoria Tipo / Kategori /**
Soort / Categoria / kategori / Typ
- II **Hersteller (Typ) / Make (Type) / Marque (Type) / Marca (Tipo) /**
Marca (Codice) / Producent (Type) / Merk (Type) / Marca (Tipo) /
Tillverkare (Typ) / Producent
- III **Nennleistung / Nominal-performance / La puissance nominale / Prestazione nominale /**
Potencia nominal / Nominaal vermogen / Nominel ydelse / Potência nominal / Nominell
effect / Moc
- IV **gemessener Schalleistungspegel / measured sound power level / niveau de**
puissance acoustique mesure / livello di potenza sonora rilevato / nivel de potencia
acústica medido / gemeten geluidsvermogensniveau / målt lydeffektniveau / Nivel de
potência sonora midido / uppmätt ljudeffektnivå / Mierzony poziom dźwięku
- V **garantierter Schalleistungspegel / guaranteed sound power level / niveau de**
puissance acoustique garanti / livello di potenza sonora garantito / nivel de potencia
acústica garantizado / gwarantowany poziom mocy akustycznej / gwarantet lydeffektniveau /
Nivel sonoro garantido / gwarantad ljudeffektniva / Natężenie hałas
- VI **beteiligte Zertifizierungsstelle / notified body involved / de l'organisme notifié/**
dell'organismo notificato che l'ha effettuata / dirección del organismo notificado que haya
intervenido / betrokken aangemelde instantie / pågældende bemyndigede organ /
organismo notificado involucrado / berörda anmälda organets namn / Jednostka
certyfikująca
- VII **Konformitäts-Bewertungsverfahren / Conformity assessment procedure followed /**
la procédure appliquée pour l'évaluation de la conformité et / procedura di valutazione
della conformità / procedimiento de evaluación de la conformidad / gevolgde
overeenstemmingsbeoordelingsprocedure / den fulgte
overensstemmelssesvurderingsprocedure / procedimento de avaliacao de conformidade
/ Vilket förfarande för bedömning av överensstämmelse / Przebieg kontroli

**Bodenverdichter
CR 4**



P = 5,6 / 6,6 kW

LWA = 107 dB (A)

LWA = 108 dB (A)

**RWTÜV
Postfach 103161
D-45032 Essen**

**interne Fertigungskontrolle
nach Anhang VI
EG Richtlinie 2000/14/EG**

ist in Übereinstimmung mit folgenden Richtlinien hergestellt worden /has been produced in accordance with following standards / est produit conforme aux dispositions des directives europeenes ci-apres / ha sido fabricado en conformidad con las siguientes normas / é stato fabbricato in conformità alle sequenti norme / er blevet fremstillet i overensstemmelse med følgende retningslinier / in overensstemming met de volgende voorschriften gefabriceerd is / é fabricado conforme as seguintes normas / har tillverkats i överensstämmelse med följande riktlinjer / Zgodność z obowiązującymi przepisami

98/37/EG Maschinenrichtlinie des europäischen Parlamentes und des Rates vom 22. Juni 1998
2000/14/EG EG-Richtlinie Geräuschemissionen vom 8. Mai 2000
EN 500 Teil 1 Bewegliche Straßenbaumaschinen – Sicherheit
Gemeinsame Anforderungen
EN 500 Teil 4 Bewegliche Straßenbaumaschinen – Sicherheit
Besondere Anforderungen an Verdichtungsmaschinen

Bescheinigung bitte sorgfältig aufbewahren / File certificate carefully / Conserver certificat soigneusement / Conservar certificado cuidadosamente / Pregasi conservare accuratamente certificato / Beviset bedes opbevares omhyggeligt / Verklaring a.u.b. zorgvuldig bevare / Conservar o certificado com cuidado / Beviset skall om sorgsfullt bevaras // Deklarację zgodności proszę zachować

Bad Laasphe – Rückershausen, den **02.01.2005**

W. Weber, Geschäftsführer

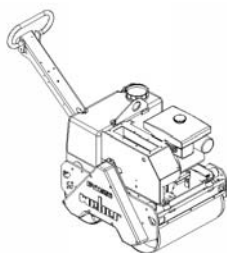

WEBER Maschinentechnik GmbH

Im Boden 5-8, 10 – D-57334 Bad Laasphe
Postfach 2153 – D-57329 Bad Laasphe
Telefon: 02754/398-0 – Fax 02754/398-101
E-mail: Verkauf@webermt.de
Internet: <http://www.webermt.de>



BITTE, NOTIEREN SIE SERIENNUMMER UND MOTORNUMMER IHRER MASCHINE:

PLEASE WRITE DOWN SERIALNUMBERS OF MACHINE AND ENGINE:

NOTEZ SVP LE NUMERO DE SERIE ET LE NUMERO DU MOTEUR DE VOTRE MACHINE:

SI PREGA DI ANNOTARE SEMPRE I NUMERI DI SERIE SIA DELLA VS. MACCHINA CHE DEL MOTORE:

MAQUINA: ROGAMOS ANOTEN EL NUMERO DE SERIE Y NUMERO DE MOTOR DE SU MAQUINA:

MASCHINE
MACHINE
MACCHINA
MAQUINA

#

MOTOR
ENGINE
MOTEUR
MOTORE

#

ZUR VERMEIDUNG VON FEHLLIEFERUNGEN UND VERZÖGERUNGEN SIND BEI DER BESTELLUNG VON ERSATZTEILEN FOLGENDE ANGABEN UNBEDINGT ERFORDERLICH:

- MASCHINENTYP
- SERIENNUMMER DER MASCHINE
- SERIENNUMMER DES MOTORS (BEI MOTORTEILEN)
- TEILENUMMER
- BESTELLMENGE

TO AVOID ERRORS IN DELIVERY PLEASE STATE THESE PARTICULARS WHEN ORDERING:

- TYPE OF MACHINE
- SERIAL NO. OF MACHINE
- SERIAL NO. OF ENGINE (ON ENGINE PARTS)
- PART-NO.
- QUANTITY REQUIRED

AFIN D'EVITER DES ERREURS DE COMMANDE ET DES RETARDS DE LIVRAISON IL EST NECESSAIRE D'INDIQUER LES CARACTERISTIQUES SUIVANTES:

- TYPE DE MACHINE
- LE NUMERO DE SERIE DE LA MACHINE
- LE NUMERO DE SERIE DU MOTEUR
- LE NUMERO D'IDENTITE DE LA PIECE
- LA QUANTITE SOUHAITEE

ONDE EVITARE DISGUIDI E RITARDI NELLE CONSEGNE DIE RICAMBI SI PREGA DI INDICARE SEMPRE:

- TIPO DELLA MACCHINA
- NUMERO DI SERIE DELLA MACCHINA
- NUMERO DI SERIE DEL MOTORE (SE SI RICHIEDONO PEZZI DEL MOTORE)
- NUMERO D'ORDINE DIE SINGOLI RICAMBI
- QUANTITA

A FI DE EVITAR ERRORES DE ENTREGA, ROGAMOS INDIQUEN LOS SIGUIENTES DATOS CUANDO PASE PEDIDOS DE RECAMBIO:

- MODELO DE MAQUINA
- NO. DE SERIE DE LA MAQUINA
- NO. DE SERIE DEL MOTOR (EN PIEZAS PARA MOTOR)
- REFERENCIA DEL RECAMBIO
- CANTIDAD PEDIDA

E 3022-0805

Position Ref.No. Repère Posizione Posicion	Menge Quantity Quantité Quantità Cantidad	Teile-Nr. Part-No. No. Référence Nr. d'Ordine No. Referenzia	Hinweis Hints Indications Indicazione Indicaciones	Position Ref. No. Repère Posizione Posicion	Menge Quantity Quantité Quantità Cantidad	Teile-Nr. Part-No. No. Référence Nr. d'Ordine No. Referenzia	Hinweis Hints Indications Indicazione Indicaciones
1	1	10016218					
2	1	25030002	DIN908-M14x1,5				
3	4	20004058					
4	4	20029030	SKM 16				
5	4	25031006	DIN934-M16				
8	1	10001419					
9	6	25045047	DIN912-M12x90-12.9				
10	2	25045048	DIN912-M12x150-12.9				
11	8	20029026					
12	4	25038023	DIN933-M16x25				
13	4	20029030	SKM 16				

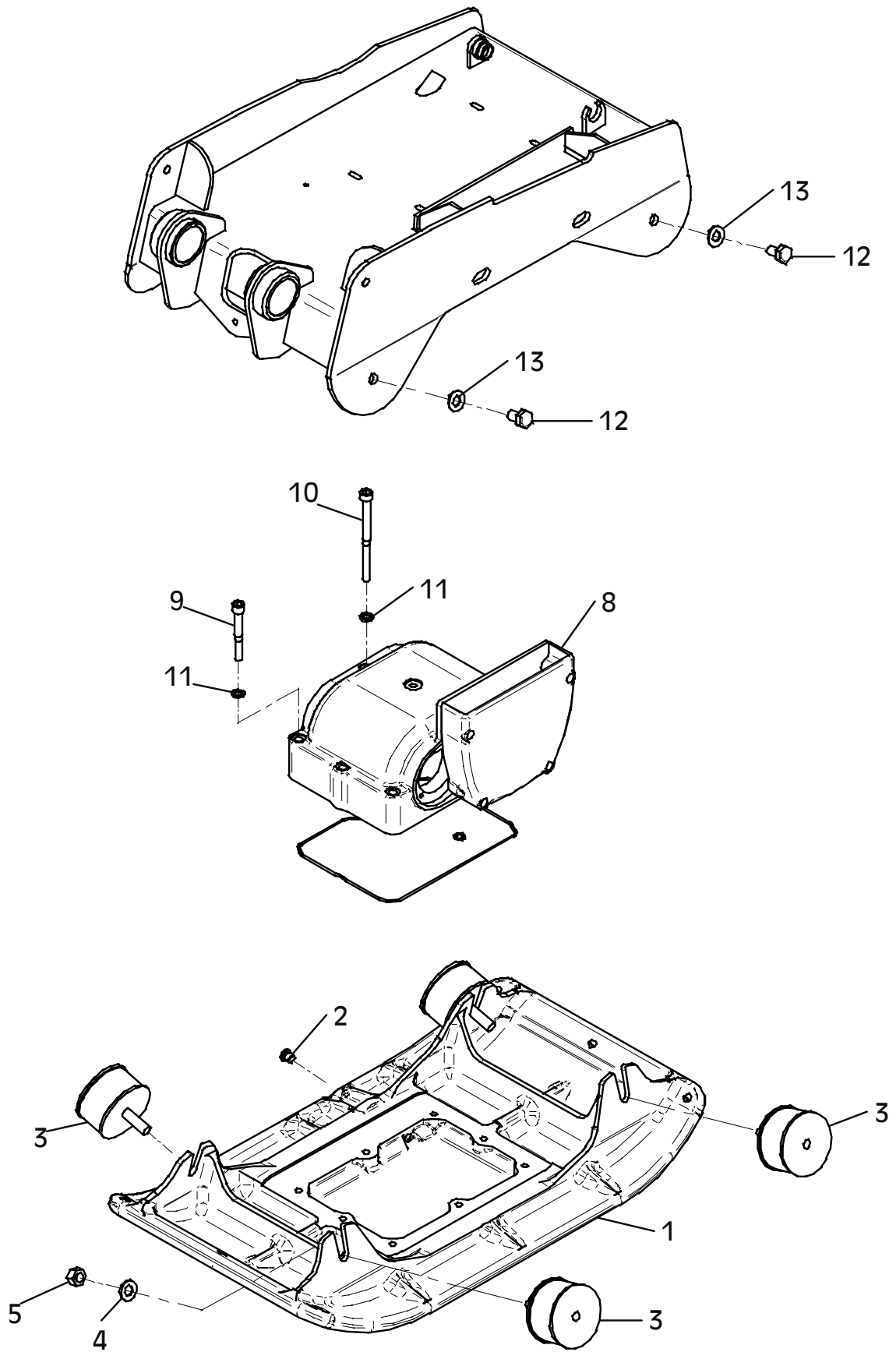

E 3022-0805

E 3023-0805

Position Ref.No. Repère Posizione Posicion	Menge Quantity Quantité Quantità Cantidad	Teile-Nr. Part-No. No. Référence Nr. d'Ordine No. Referenzia	Hinweis Hints Indications Indicazione Indicaciones	Position Ref. No. Repère Posizione Posicion	Menge Quantity Quantité Quantità Cantidad	Teile-Nr. Part-No. No. Référence Nr. d'Ordine No. Referenzia	Hinweis Hints Indications Indicazione Indicaciones
1	1	10016219					
2	1	25030002	DIN908-M14x1,5				
3	4	20004058					
4	4	20029030	SKM 16				
5	4	25031006	DIN934-M16				
8	1	10001419					
9	6	25045047	DIN912-M12x90-12.9				
10	2	25045048	DIN912-M12x150-12.9				
11	8	20029026					
12	4	25038023	DIN933-M16x25				
13	4	20029030	SKM 16				

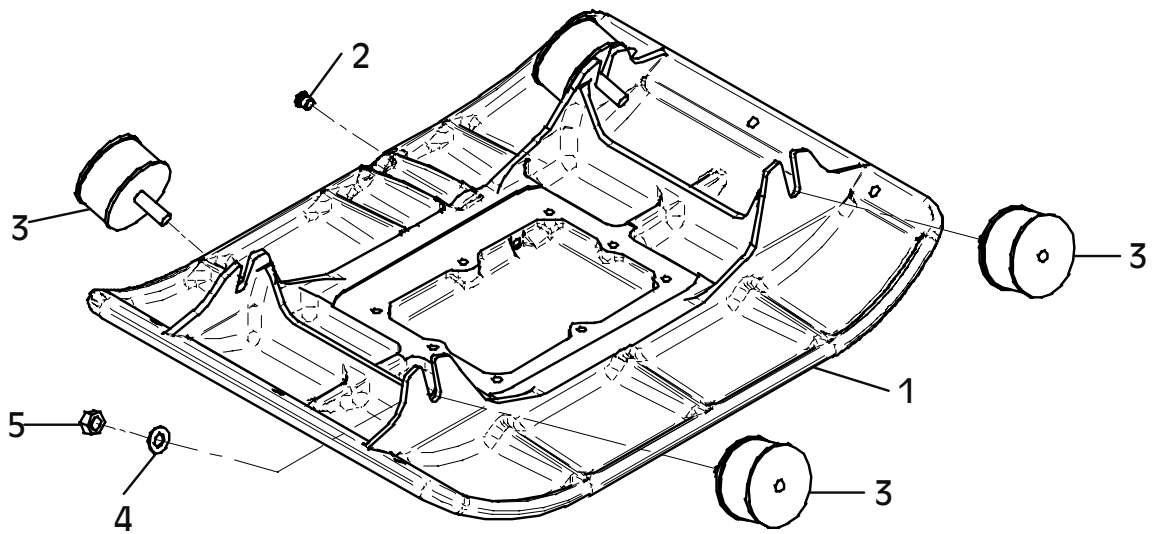
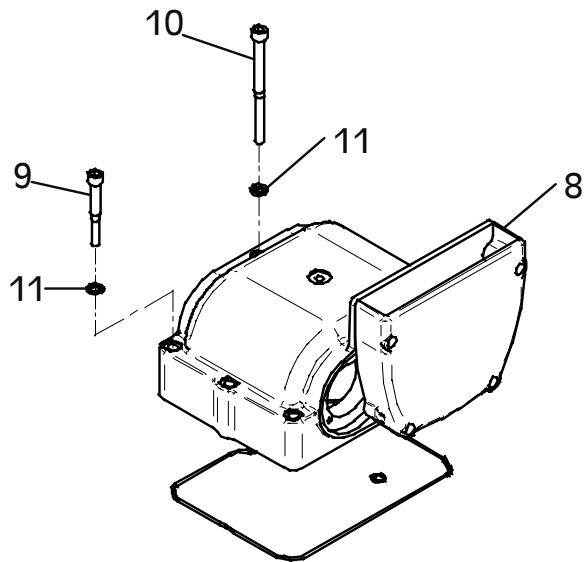
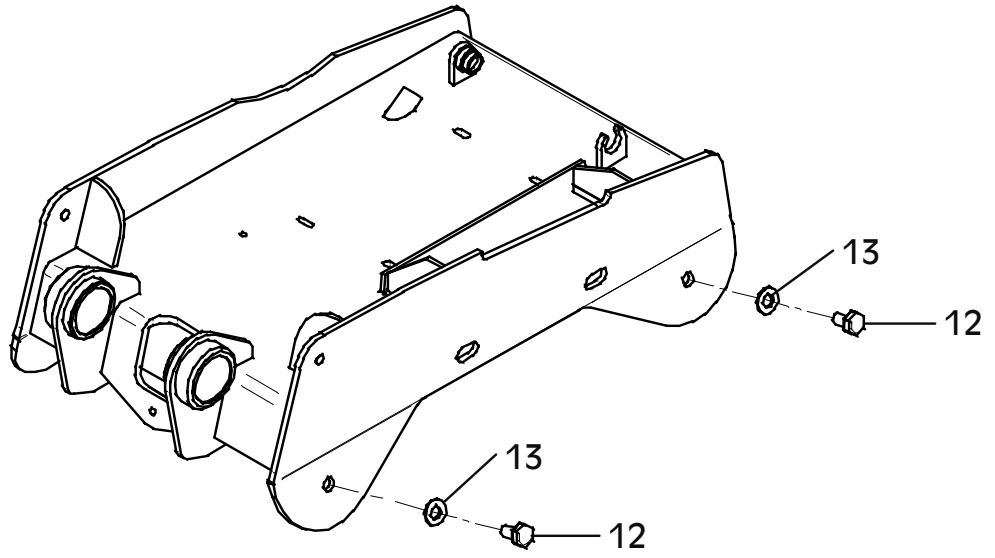

E 3023-0805

E 3024-0805

Position Ref.No. Repère Posizione Posicion	Menge Quantity Quantité Quantità Cantidad	Teile-Nr. Part-No. No. Référence Nr. d'Ordine No. Referenzia	Hinweis Hints Indications Indicazione Indicaciones	Position Ref. No. Repère Posizione Posicion	Menge Quantity Quantité Quantità Cantidad	Teile-Nr. Part-No. No. Référence Nr. d'Ordine No. Referenzia	Hinweis Hints Indications Indicazione Indicaciones
1	1	10016363		30	2	10016060	
2	1	25039005	DIN933-M12x20	31	8	20029011	VSKZ 8
3	1	25008011	DIN7603-12x18x1,5	32	8	25044100	DIN912-M8x16
4	1	10016389		33	1	20013269	
5	4	25044055	DIN912-M8x50	34	1	10016064	
6	4	20029011	VSKZ 8	35	4	20029011	VSKZ 8
7	1	10016250		36	4	25044100	DIN912-M8x16
8	1	10016071		37	1	25008012	DIN7603-10x16x1
9	1	20029001	VSK 10	38	1	25030016	DIN910-M10x1
10	1	10007370		39	1	20020119	
11	1	10016061		40	1	10016067	
12	4	20029011	VSKZ 8	41	2	10016247	
13	4	25046015	DIN7984-M8x16	42	2	25025245	
14	1	20013269		43	2	25045029	DIN912-M10x45-10.9
15	1	25017047		44	2	25001151	
16	2	25001151		45	1	10016063	
17	1	10016245		46	2	25001022	
18	2	10016246		47	2	10016074	
19	2	25025245		48	1	10008320	
20	2	25045028	DIN912-M10x35-10.9	49	1	25027004	DIN914-M8x16
21	1	10016247		50	1	10017399	
22	1	25025245		51	1	25035025	DIN472-I24x1,2
23	1	25045029	DIN912-M10x45-10.9	52	2	25001705	
24	1	10016062		53	1	25034032	DIN471-A9x1
25	1	25015046		54	1	10017370	
26	0	20025528		55	1	20013270	
27	0	20025029		56	1	20013302	
28	0	20025378		57	1	20013103	
29	2	20013269					

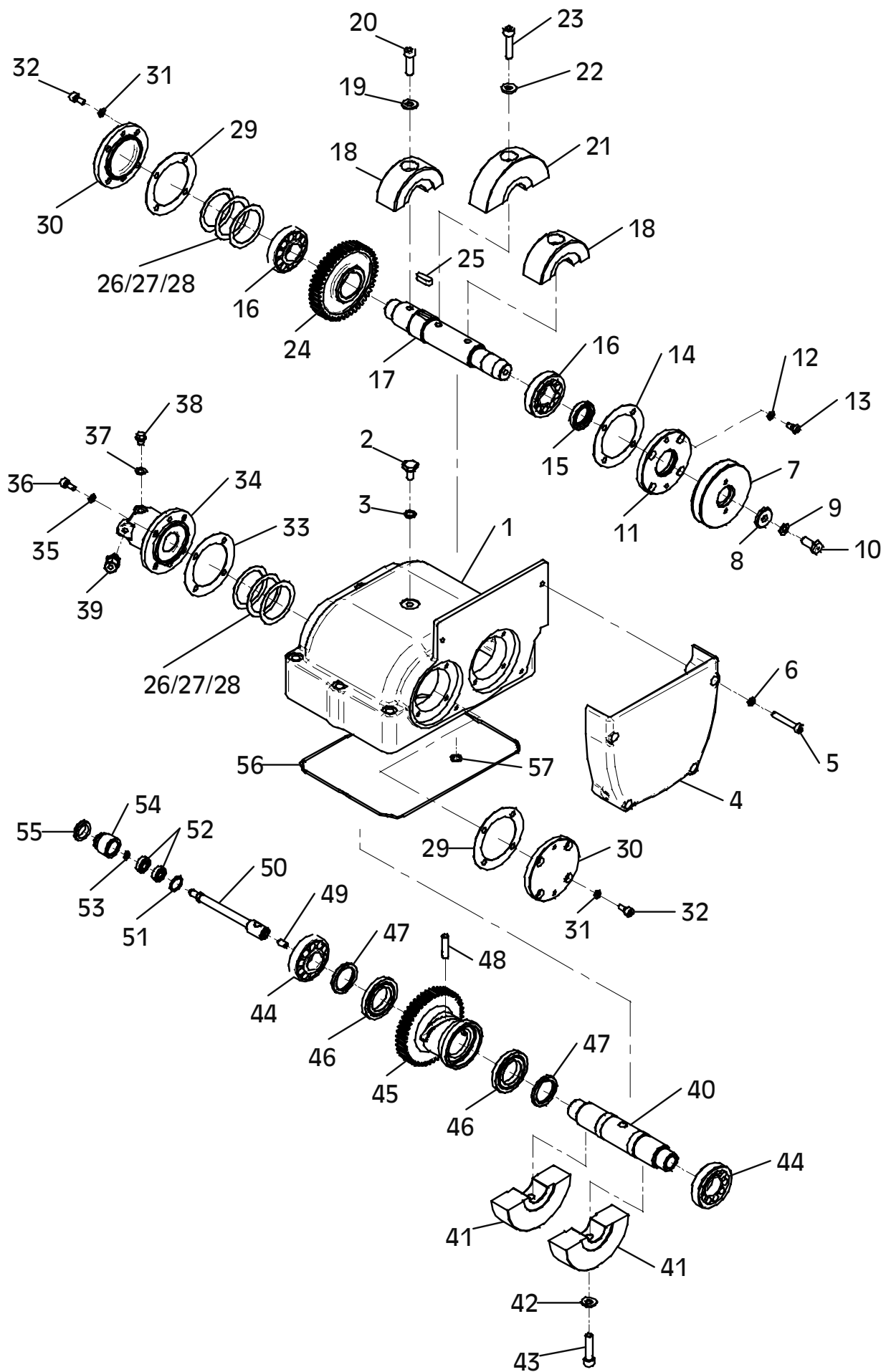

E 3024-0805

E 3025-0805

Position Ref.No. Repère Posizione Posicion	Menge Quantity Quantité Quantità Cantidad	Teile-Nr. Part-No. No. Référence Nr. d'Ordine No. Referenzia	Hinweis Hints Indications Indicazione Indicaciones	Position Ref. No. Repère Posizione Posicion	Menge Quantity Quantité Quantità Cantidad	Teile-Nr. Part-No. No. Référence Nr. d'Ordine No. Referenzia	Hinweis Hints Indications Indicazione Indicaciones
1	1	10022505		30	4	20029011	VSKZ 8
2	1	20005004		31	4	25044095	DIN912-M8x90
3	2	25049016	DIN440-R9	32	1	25031002	DIN934-M6
4	1	20029003	VSK 8	33	1	40031335	
5	1	25031003	DIN934-M8	34	1	40031336	
6	1	20007007		35	1	40031334	
7	1	25048001	DIN125-B6,4	36	1	40031514	
8	1	25038069	DIN933-M6x25	37	1	25008017	DIN 7603-22x27x1,5
9	1	20029007	VSK 6	38	1	20025765	
10	1	25031002	DIN934-M6	39	1	20007007	
11	1	20025590		40	1	10022506	
12	1	20025271		41	4	25038021	DIN933-M12x35
13	1	25009021		42	4	20029004	VSK 12
14	1	20001232		43	2	25031027	DIN1587-M12
15	4	25033024	DIN603-M8x30	44	1	20026465	
16	4	20029024		45	2	25025191	DIN80705-M20x1,5
17	4	25031003	DIN934-M8	46	2	20025019	
18	1	10022513		47	2	25048004	DIN125-A13
19	4	20029001	VSK 10				
20	4	25038013	DIN933-M10x20				
21	1	20002086					
22	1	25002092					
23	1	25049016	DIN440-R9				
24	1	20029011	VSKZ 8				
25	1	25044009	DIN912-M8x45				
26	1	10016249					
27	4	20029011	VSKZ 8				
28	4	25038006	DIN933-M8x16				
29	1	10016251					

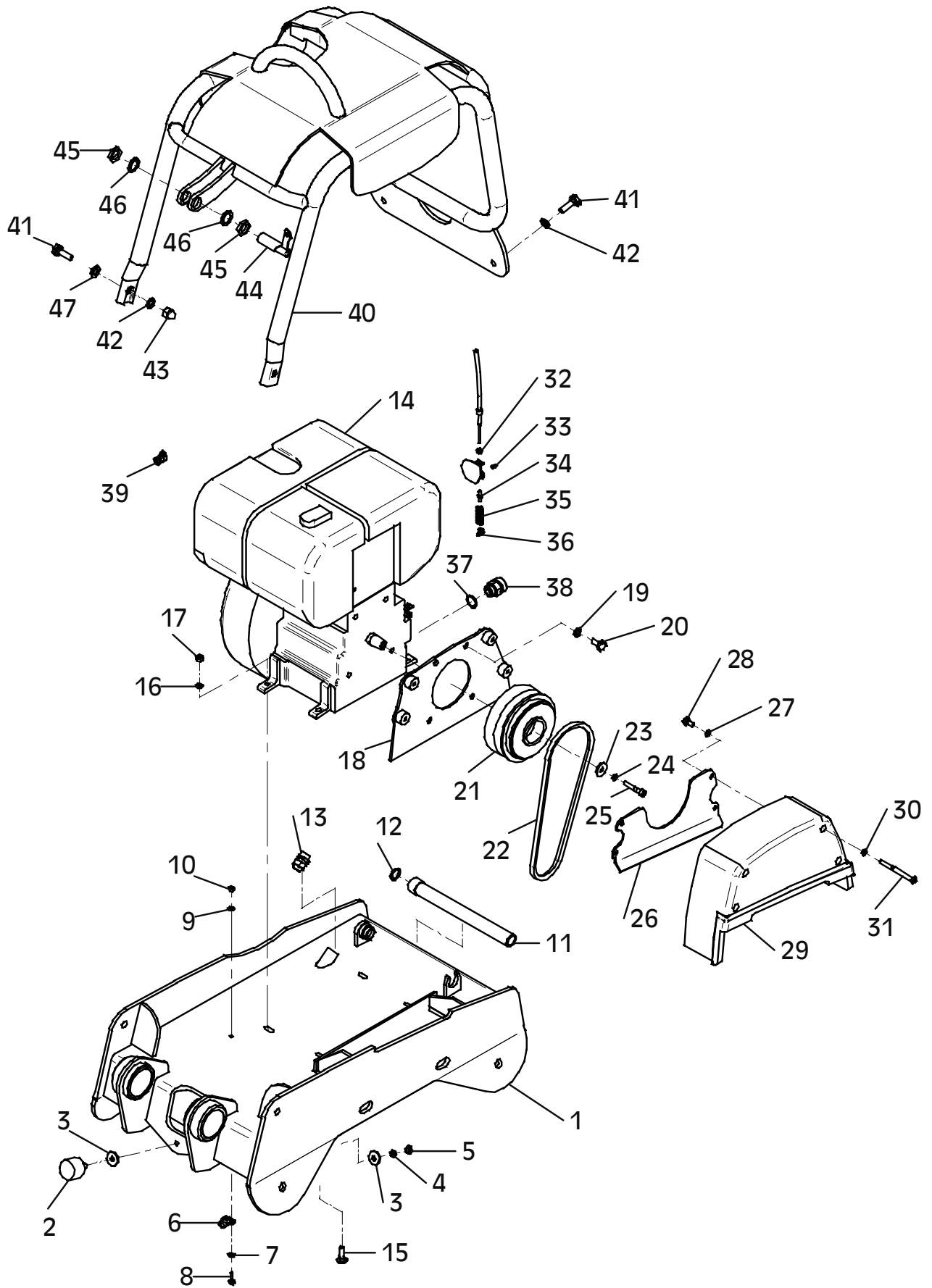

E 3132-0805

Position Ref.No. Repère Posizione Posicion	Menge Quantity Quantité Quantità Cantidad	Teile-Nr. Part-No. No. Référence Nr. d'Ordine No. Referenzia	Hinweis Hints Indications Indicazione Indicaciones	Position Ref. No. Repère Posizione Posicion	Menge Quantity Quantité Quantità Cantidad	Teile-Nr. Part-No. No. Référence Nr. d'Ordine No. Referenzia	Hinweis Hints Indications Indicazione Indicaciones
1	1	10022621		30	4	20029011	VSKZ 8
2	1	20005004		31	4	25044095	DIN912-M8x90
3	2	25049016	DIN440-R9	32	1	25031002	DIN934-M6
4	1	20029003	VSK 8	33	1	40031335	
5	1	25031003	DIN934-M8	34	1	40031336	
6	1	20007007		35	1	40031334	
7	1	25048001	DIN125-B6,4	36	1	40031514	
8	1	25038002	DIN933-M6x16	37	1	25008017	DIN 7603-22x27x1,5
9	2	25048002	DIN125-A8,4	38	1	20025765	
10	1	20029003	VSK 8	39	1	20007007	
11	1	20025590		40	1	10022506	
12	1	20025271		41	4	25038021	DIN933-M12x35
13	1	25009021		42	4	20029004	VSK 12
14	1	20001241		43	2	25031027	DIN1587-M12
15	3	25033024	DIN603-M8x30	44	1	20026465	
16	4	20029024		45	2	25025191	DIN80705-M20x1,5
17	5	25031003	DIN934-M8	46	2	20025019	
18	1	10022513		47	1	25033015	DIN603-M8x40
19	4	20029001	VSK 10	48	2	25048004	DIN125-A13
20	4	25038013	DIN933-M10x20				
21	1	20002086					
22	1	25002092					
23	1	25049016	DIN440-R9				
24	1	20029011	VSKZ 8				
25	1	25044009	DIN912-M8x45				
26	1	10016249					
27	4	20029011	VSKZ 8				
28	4	25038006	DIN933-M8x16				
29	1	10016251					

Hatz

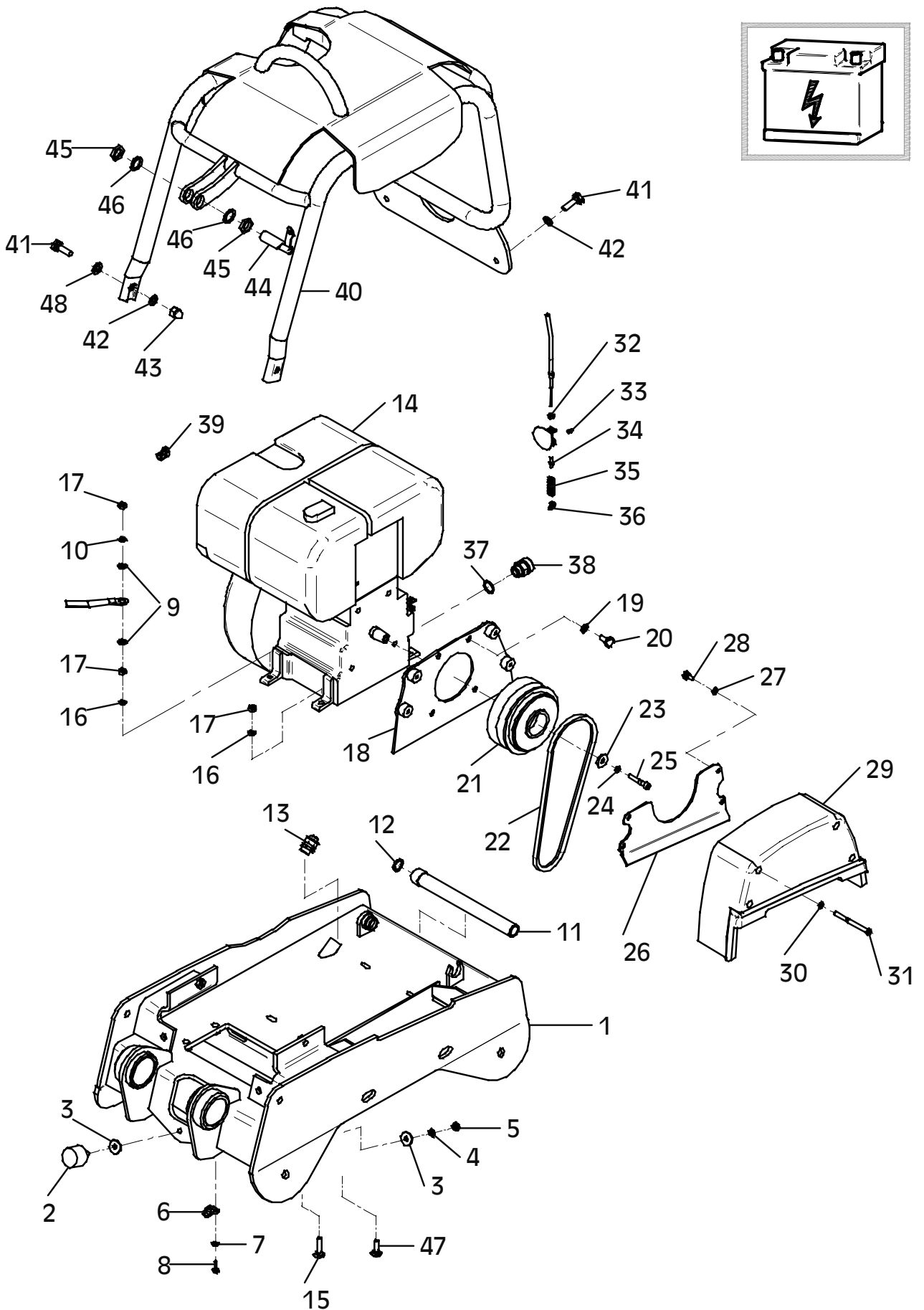
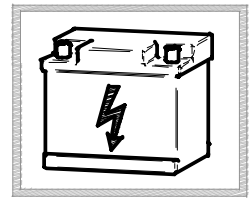

E 3132-0805

E 3027-0202

Position Ref.No. Repère Posizione Posicion	Menge Quantity Quantité Quantita Cantidad	Teile-Nr. Part-No. No. Référence Nr. d'Ordine No. Referenzia	Hinweis Hints Indications Indicazione Indicaciones	Position Ref. No. Repère Posizione Posicion	Menge Quantity Quantité Quantita Cantidad	Teile-Nr. Part-No. No. Référence Nr. d'Ordine No. Referenzia	Hinweis Hints Indications Indicazione Indicaciones
1	1	20002086					
2	2	20002548					
3	2	20002269					

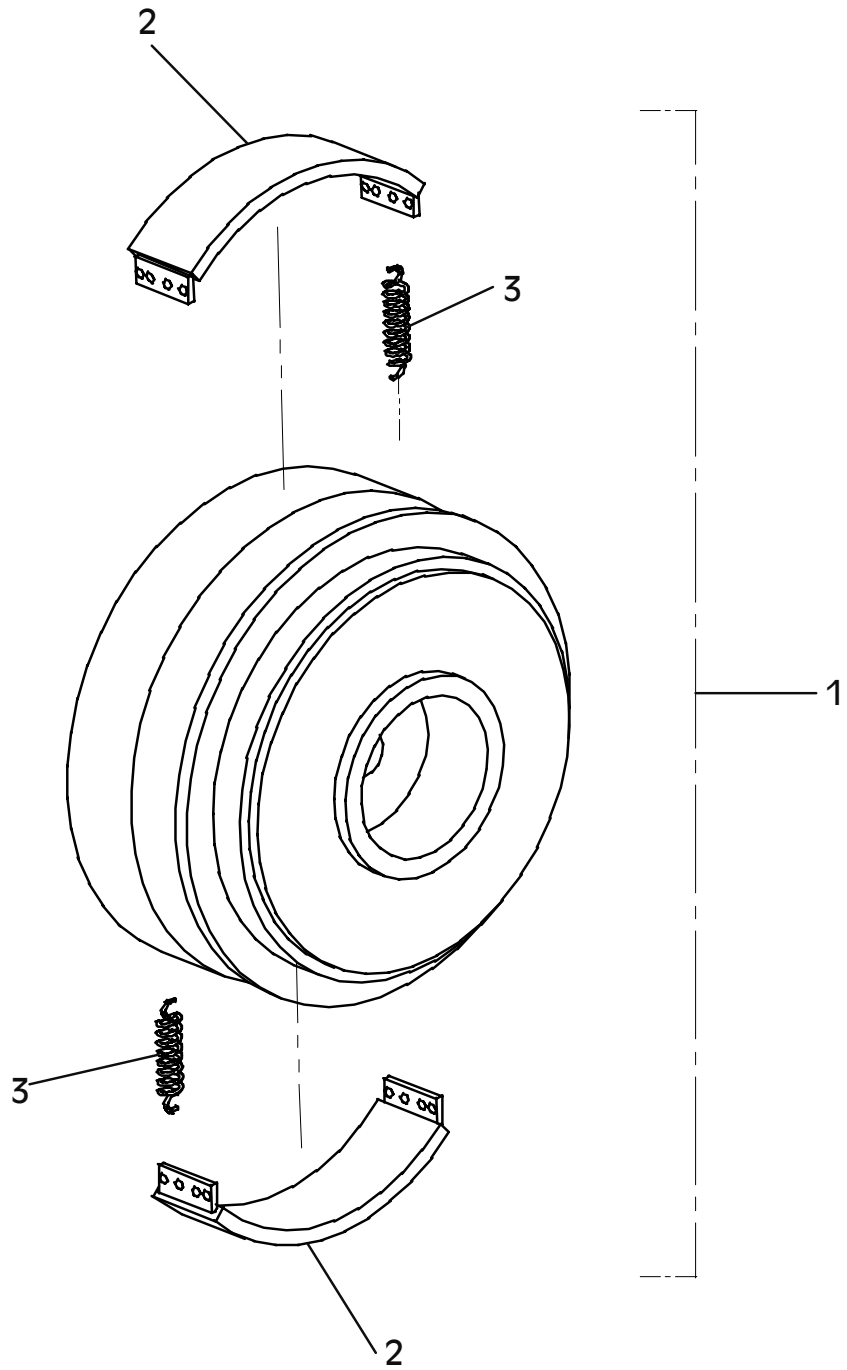

E 3133-0304

Position Ref.No. Repère Posizione Posicion	Menge Quantity Quantité Quantita Cantidad	Teile-Nr. Part-No. No. Référence Nr. d'Ordine No. Referenzia	Hinweis Hints Indications Indicazione Indicaciones	Position Ref. No. Repère Posizione Posicion	Menge Quantity Quantité Quantita Cantidad	Teile-Nr. Part-No. No. Référence Nr. d'Ordine No. Referenzia	Hinweis Hints Indications Indicazione Indicaciones
1	1	10022623					
2	4	25038014	DIN933-M10x25				
3	4	20029022	SKB 10				
4	1	10022622					
5	1	20031558					
6	1	10017066					
7	1	10017067					
8	2	10017068					
9	1	10017069					
10	1	10017070					
11	1	10017064					
12	4	25044013	DIN912-M10x30				
13	4	20029022	SKB 10				
14	1	10001457					
15	1	10001458					

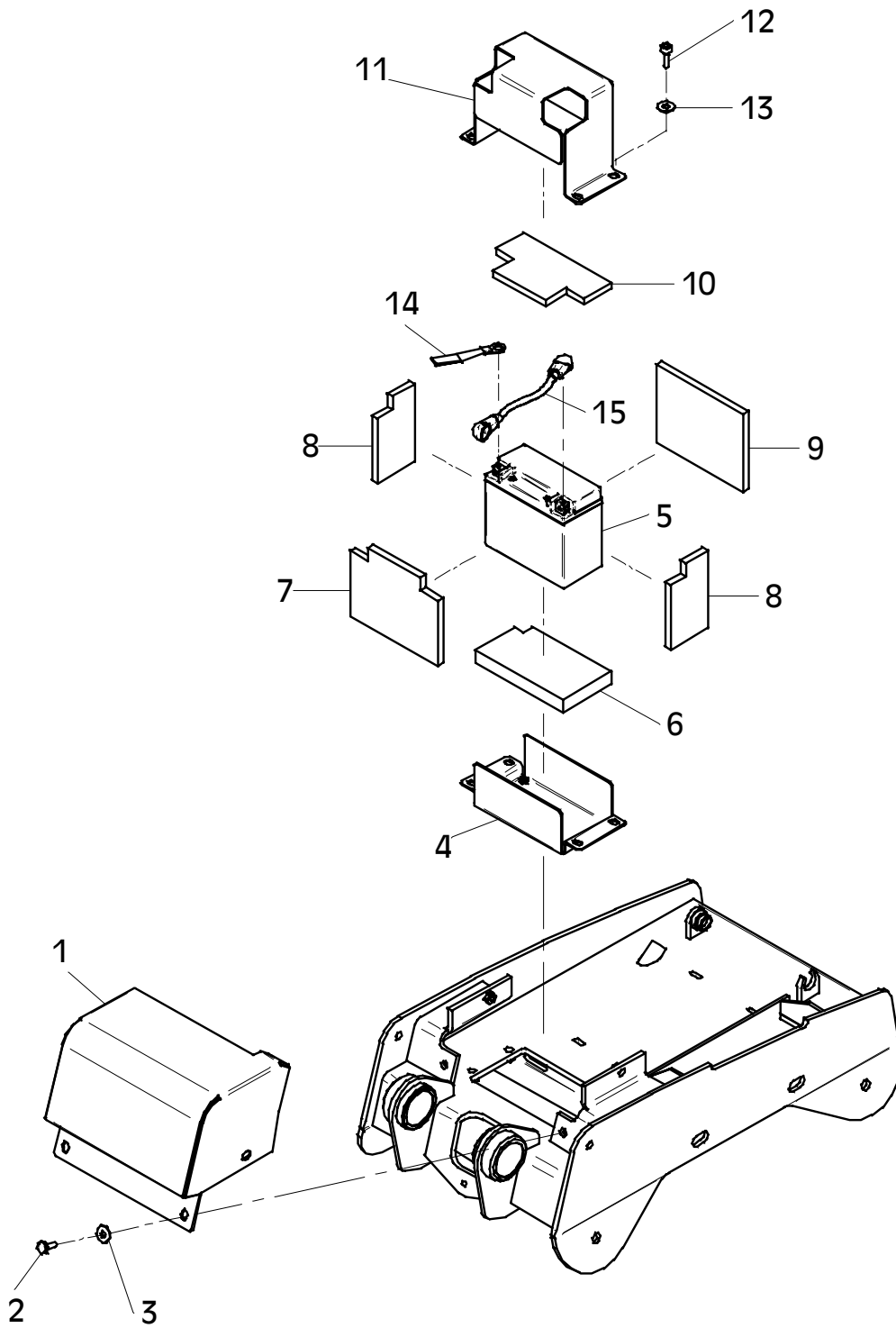

E 3026-0805

Position Ref.No. Repère Posizione Posicion	Menge Quantity Quantité Quantita Cantidad	Teile-Nr. Part-No. No. Référence Nr. d'Ordine No. Referenzia	Hinweis Hints Indications Indicazione Indicaciones	Position Ref. No. Repère Posizione Posicion	Menge Quantity Quantité Quantita Cantidad	Teile-Nr. Part-No. No. Référence Nr. d'Ordine No. Referenzia	Hinweis Hints Indications Indicazione Indicaciones
1	1	10022527		30	4	20029011	VSKZ 8
2	1	20005004		31	4	25038006	DIN933-M8x16
3	2	25049016	DIN440-R9	32	1	10016251	
4	1	20029003	VSK 8	33	4	20029011	VSKZ 8
5	1	25031003	DIN934-M8	34	4	25044095	DIN912-M8x90
6	1	20007007		35	1	25008011	DIN7603-12x18x1,5
7	1	25048001	DIN125-B6,4	36	1	20026204	
8	1	25038069	DIN933-M6x25	37	1	20026383	
9	1	20029007	VSK 6	38	1	40001338	
10	1	25031002	DIN934-M6	39	1	20007007	
11	1	20025704		40	1	25048001	DIN125-B6,4
12	1	20025434		41	1	20029007	VSK 6
13	1	25009021		42	1	25038002	DIN933-M6x16
14	1	20001230		43	1	10022529	
15	2	10016353		44	4	20029004	VSK 12
16	4	25033013	DIN603-M10x50	45	4	25038021	DIN933-M12x35
17	4	25048010	DIN1440-11x25x3	46	2	25031027	DIN1587-M12
18	4	20029025		47	1	20026465	
19	4	25031004	DIN934-M10	48	2	25025191	DIN80705-M20x1,5
20	1	10022528		49	2	20025019	
21	4	20029003	VSK 8	50	2	25048004	DIN125-A13
22	4	25038007	DIN933-M8x20				
23	1	20002087					
24	1	10016954					
25	1	25002174					
26	1	20026475					
27	1	20029011	VSKZ 8				
28	1	25044007	DIN912-M8x30				
29	1	10016249					

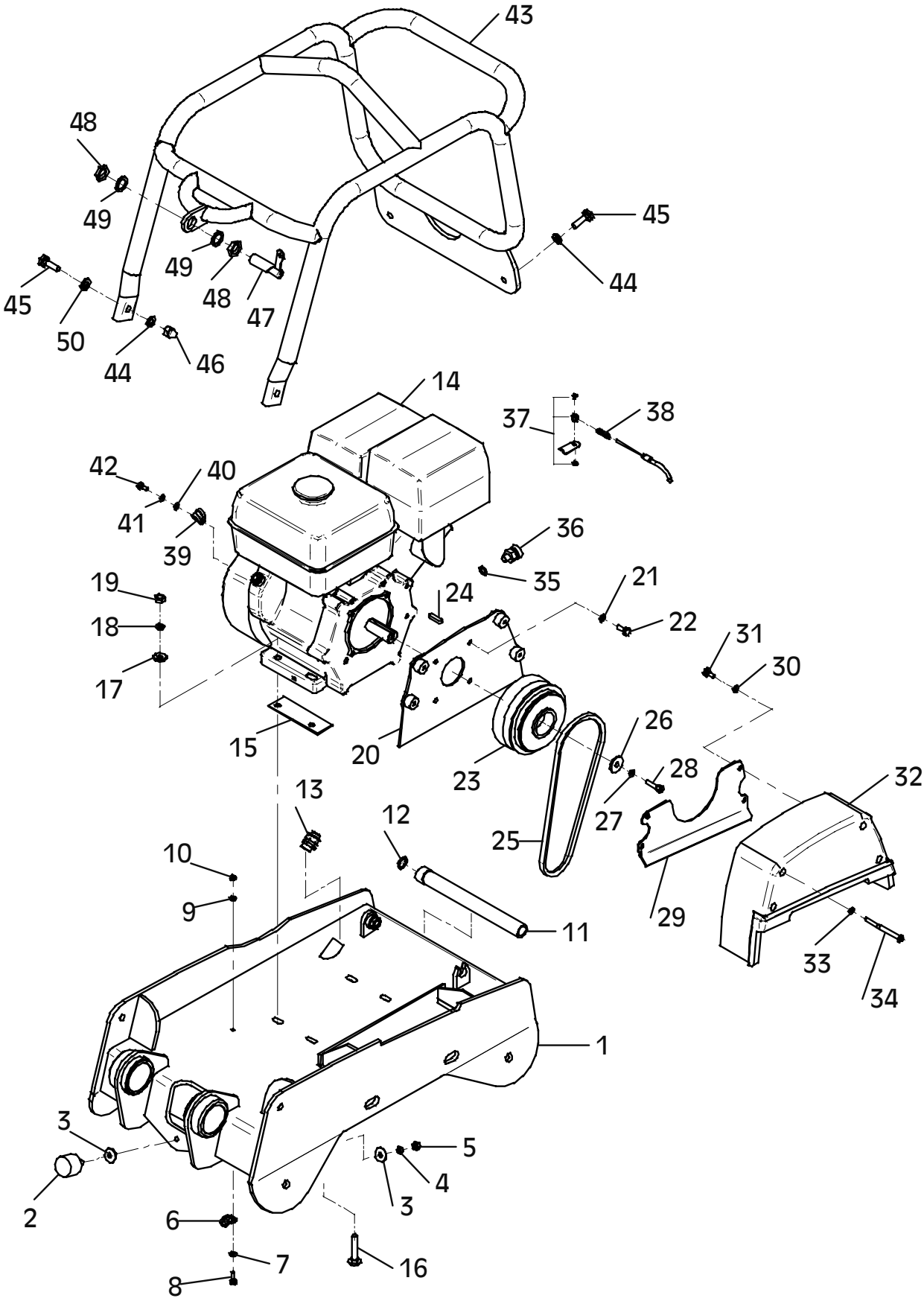

E 3028-0202

Position Ref.No. Repère Posizione Posicion	Menge Quantity Quantité Quantita Cantidad	Teile-Nr. Part-No. No. Référence Nr. d'Ordine No. Referenzia	Hinweis Hints Indications Indicazione Indicaciones	Position Ref. No. Repère Posizione Posicion	Menge Quantity Quantité Quantita Cantidad	Teile-Nr. Part-No. No. Référence Nr. d'Ordine No. Referenzia	Hinweis Hints Indications Indicazione Indicaciones
1	1	20002087					
2	2	20002548					
3	2	20002269					

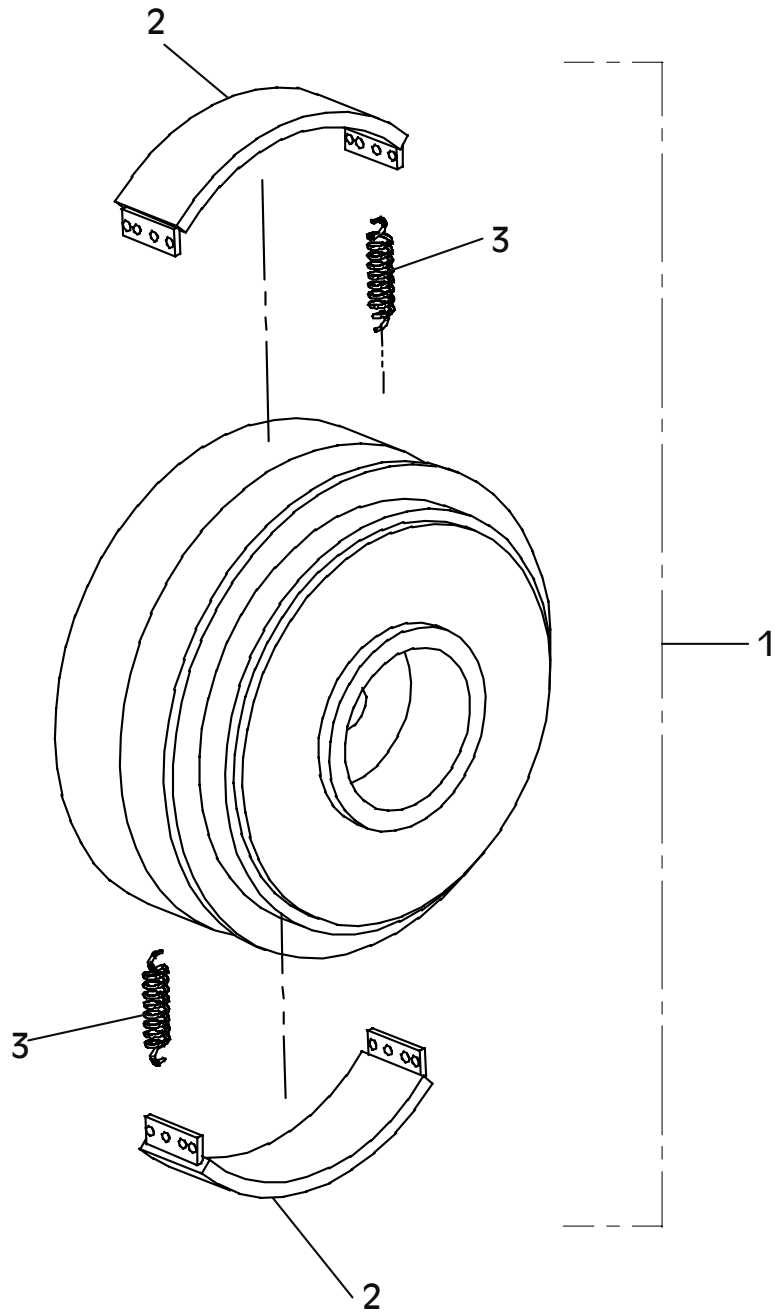

E 3202-0805

Position Ref.No. Repère Posizione Posicion	Menge Quantity Quantité Quantita Cantidad	Teile-Nr. Part-No. No. Référence Nr. d'Ordine No. Referenzia	Hinweis Hints Indications Indicazione Indicaciones	Position Ref. No. Repère Posizione Posicion	Menge Quantity Quantité Quantita Cantidad	Teile-Nr. Part-No. No. Référence Nr. d'Ordine No. Referenzia	Hinweis Hints Indications Indicazione Indicaciones
1	1	10022230		31	2	20029013	VSKZ 12
2	2	10016099		32	2	20025593	
3	2	25044066	DIN912-M12x90	33	2	11000056	
4	2	20029013	VSKZ 12	34	1	11000038	
5	2	25048012	DIN9021-13x40x3	35	4	25038008	DIN933-M8x25
6	1	10016017		36	4	20029003	VSK 8
7	1	20007202		37	1	20018134	
8	1	25009021		38	1	10016100	Hatz
9	1	20016366		38	1	10016358	Honda
10	1	20020119		39	2	25040067	DIN931-M6x30
11	1	10016798		40	2	20029007	VSK 6
12	1	25035027	DIN472-I58x2	41	1	20018021	
13	4	25044006	DIN912-M8x25	42	1	20006414	
14	4	20029011	VSKZ 8	43	2	20004036	
15	1	20013274		44	4	20033002	
16	2	20013273					
17	1	10016102					
18	1	20013275					
19	1	10016022					
20	1	20008070					
21	1	10016797					
22	1	25008008	DIN7603-24x32x2				
23	1	25030003	DIN908-M24x1,5				
24	1	25030002	DIN908-M14x1,5				
25	1	10017394					
26	2	20013271					
27	2	10017397					
28	2	25017048					
29	2	10017396					
30	2	25044035	DIN912-M12x25				

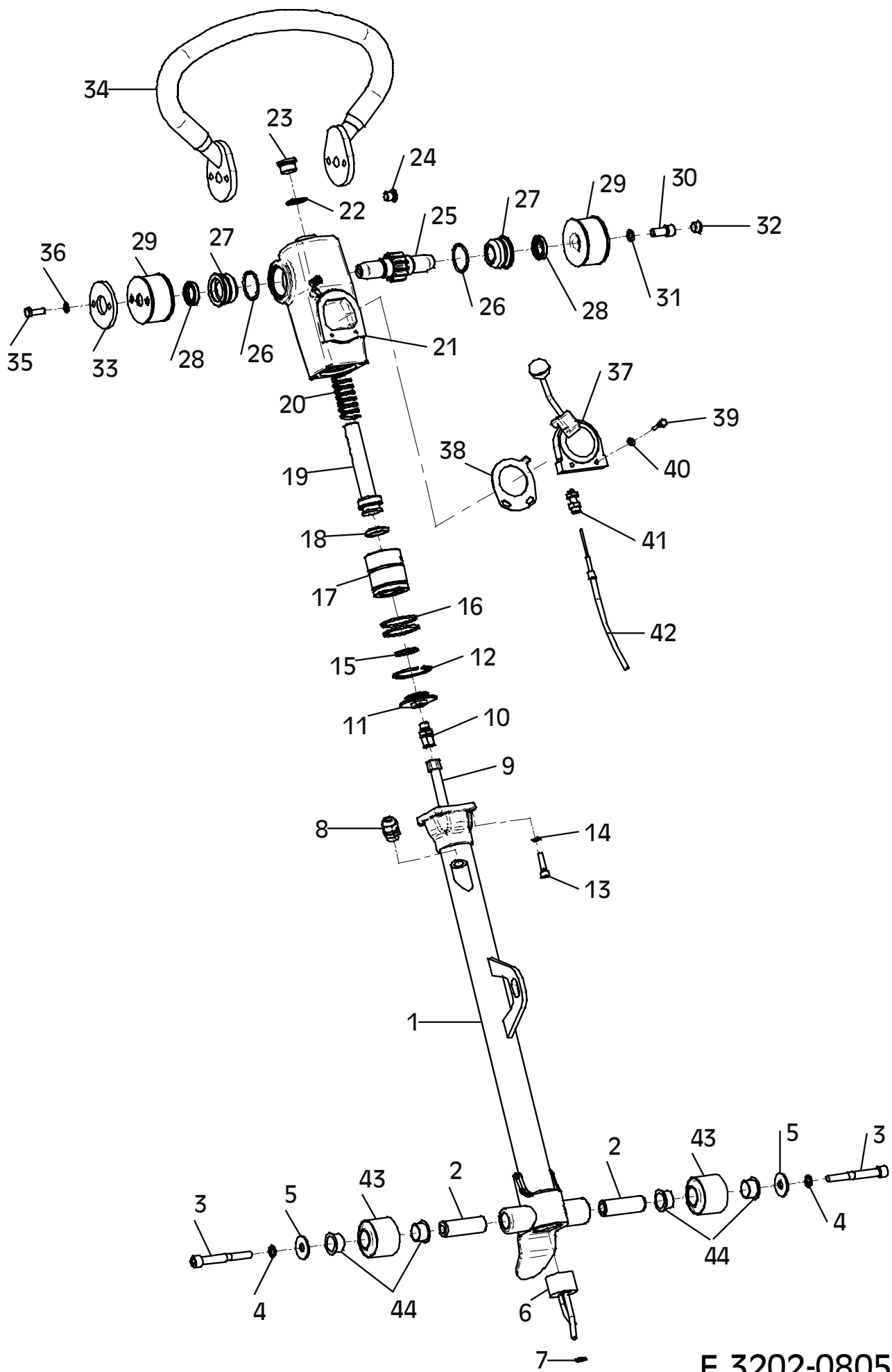

E 3202-0805

E 3030-0202

Position Ref.No. Repère Posizione Posicion	Menge Quantity Quantité Quantita Cantidad	Teile-Nr. Part-No. No. Référence Nr. d'Ordine No. Referenzia	Hinweis Hints Indications Indicazione Indicaciones	Position Ref. No. Repère Posizione Posicion	Menge Quantity Quantité Quantita Cantidad	Teile-Nr. Part-No. No. Référence Nr. d'Ordine No. Referenzia	Hinweis Hints Indications Indicazione Indicaciones
1	1	10016252					
2	2	10016114					
3	6	25040020	DIN931-M12x60				
4	6	20029004	VSK 12				
5	6	25031005	DIN934-M12				
6							
7							
8							
9							
10	1	10016351					
11	2	10016352					
12	6	25040020	DIN931-M12x60				
13	6	20029004	VSK 12				
14	6	25031005	DIN934-M12				

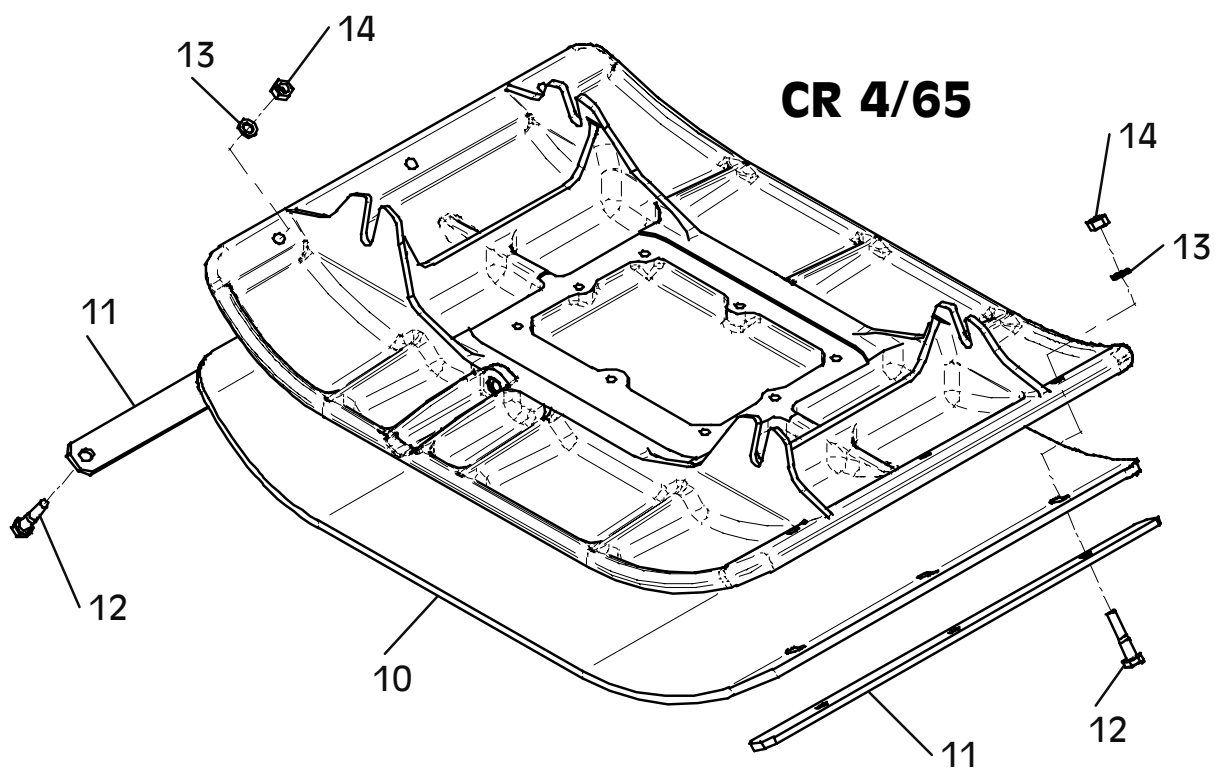
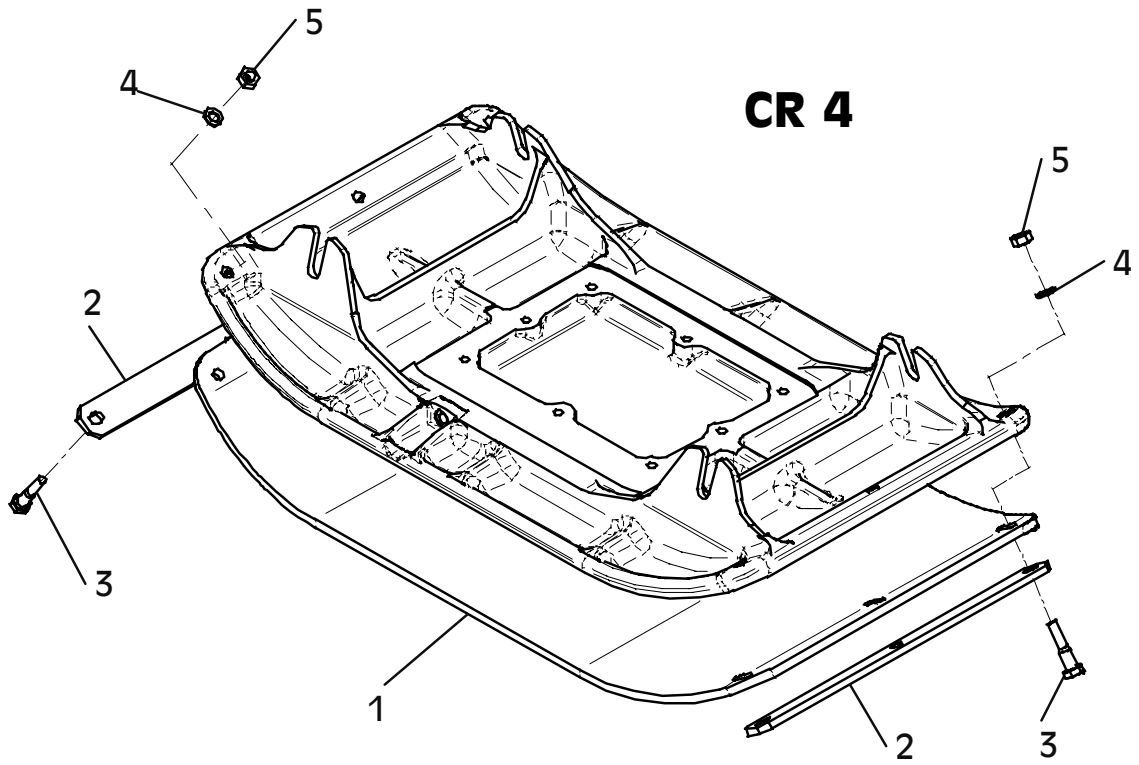

E 3031-0202

Position Ref.No. Repère Posizione Posicion	Menge Quantity Quantité Quantità Cantidad	Teile-Nr. Part-No. No. Référence Nr. d'Ordine No. Referenzia	Hinweis Hints Indications Indicazione Indicaciones	Position Ref. No. Repère Posizione Posicion	Menge Quantity Quantité Quantità Cantidad	Teile-Nr. Part-No. No. Référence Nr. d'Ordine No. Referenzia	Hinweis Hints Indications Indicazione Indicaciones
1	1	10022502					
2	1	10016239					
3	1	20025508					
4	1	25031004	DIN934-M10				
5	1	25038060	DIN933-M10x50				
6	2	20025007					
7	4	25048006	DIN125-A21				
8	2	25037011					
9	1	10022503					
10	1	25040018	DIN931-M12x50				
11	1	25040033	DIN931-M12x70				
12	2	25048004	DIN125-A13				
13	1	20029004	VSK 12				
14	1	25031005	DIN934-M12				

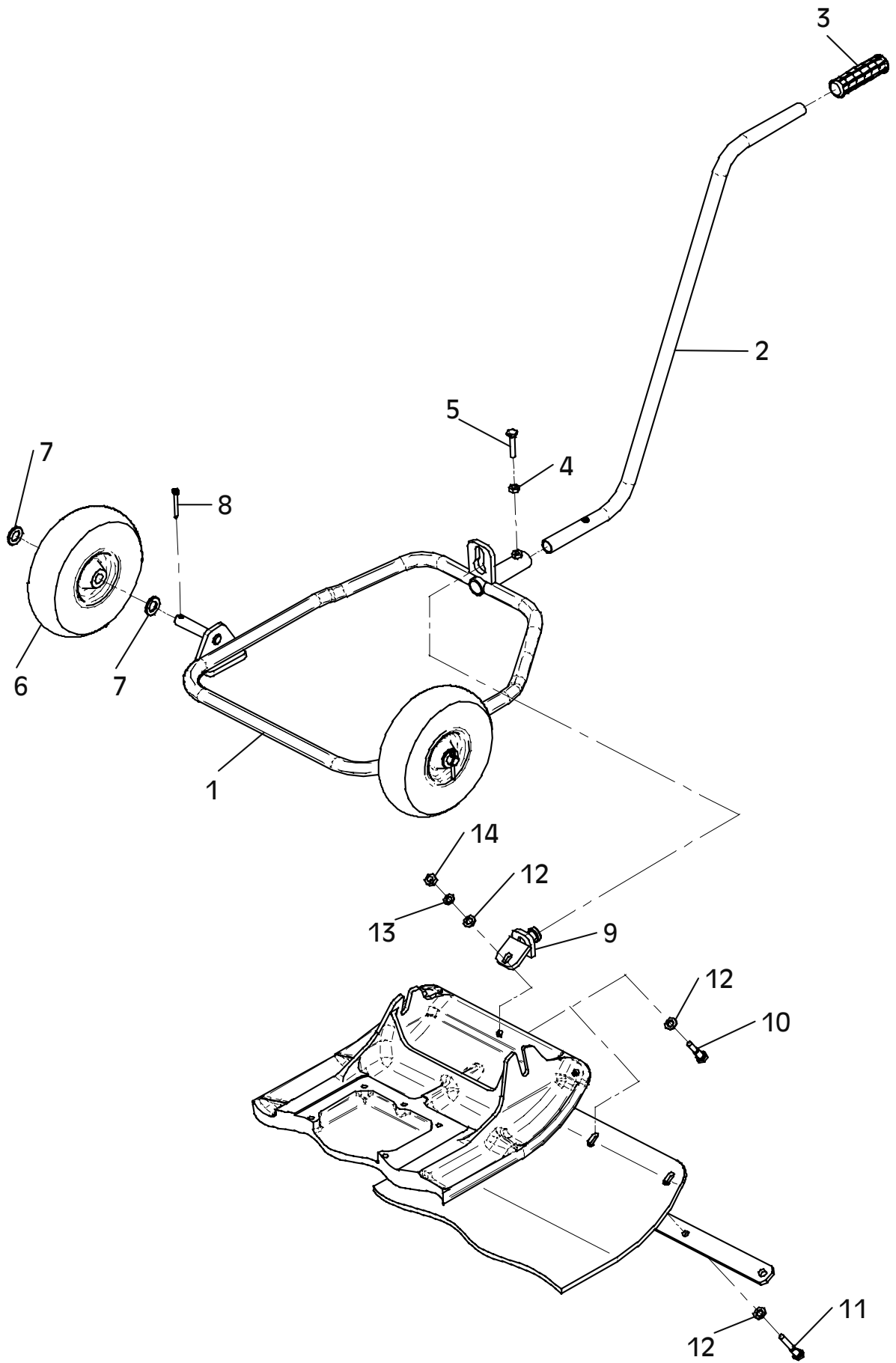

E 3031-0202

E 3032-0202

Position Ref.No. Repère Posizione Posicion	Menge Quantity Quantité Quantità Cantidad	Teile-Nr. Part-No. No. Référence Nr. d'Ordine No. Referenzia	Hinweis Hints Indications Indicazione Indicaciones	Position Ref. No. Repère Posizione Posicion	Menge Quantity Quantité Quantità Cantidad	Teile-Nr. Part-No. No. Référence Nr. d'Ordine No. Referenzia	Hinweis Hints Indications Indicazione Indicaciones
1	1	10022504					
2	1	10016239					
3	1	20025508					
4	1	25031004	DIN934-M10				
5	1	25038060	DIN933-M10x50				
6	2	20025007					
7	4	25048006	DIN125-A21				
8	2	25037011					
9	1	10022503					
10	1	25040018	DIN931-M12x50				
11	1	25040033	DIN931-M12x70				
12	2	25048004	DIN125-A13				
13	1	20029004	VSK 12				
14	1	25031005	DIN934-M12				

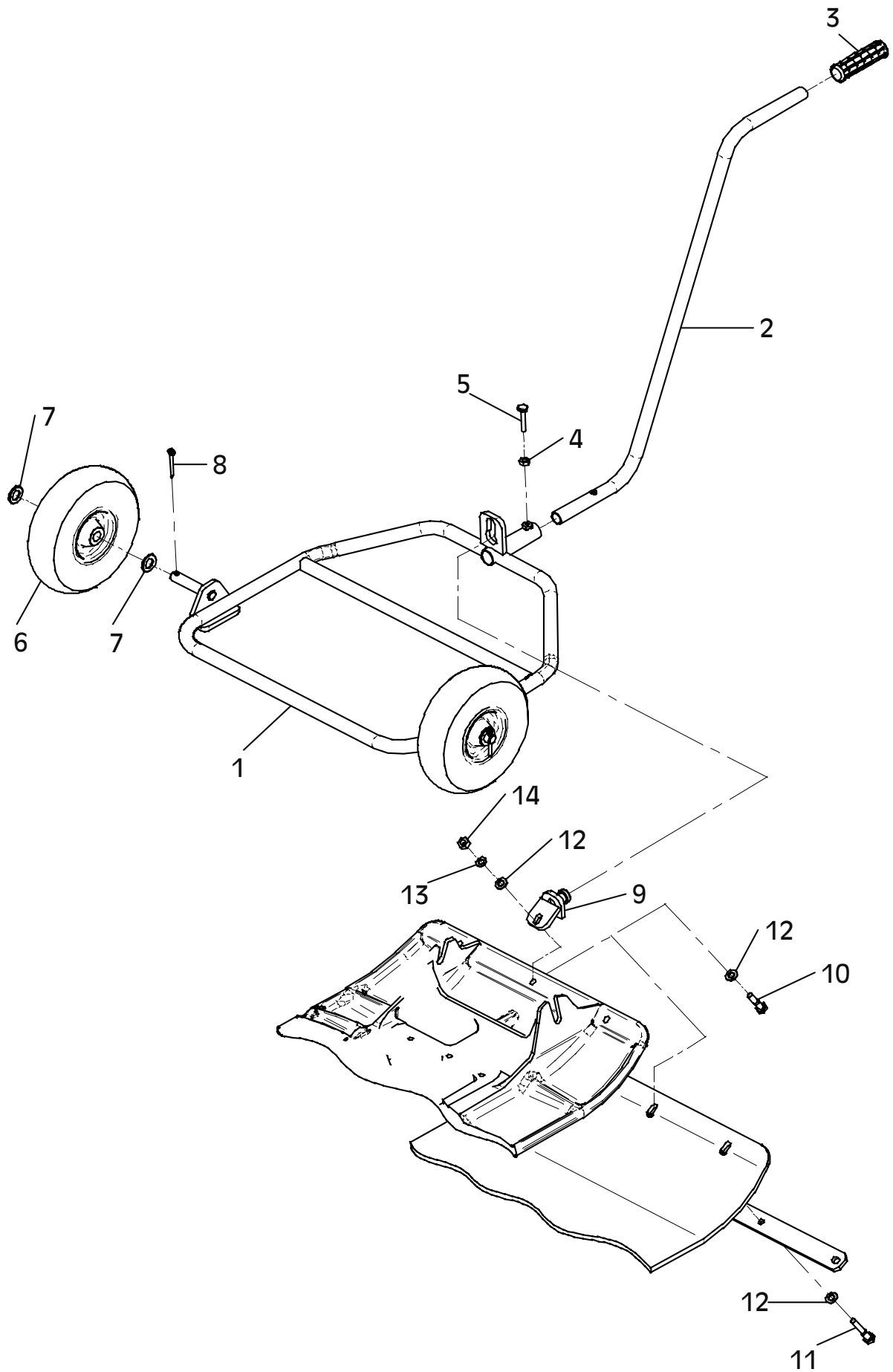

E 3032-0202

**Wenn Sie Fragen und Anregungen haben, oder sonstige Informationen benötigen,
wenden Sie sich bitte an eine der unten genannten Adressen:**

**For questions and further information refer to one of the
following addresses:**

<p>In Deutschland</p> <p>In Germany</p>	<p>WEBER Maschinenteknik GmbH Postfach 2153 57329 Bad Laasphe – Rückershausen</p> <p>Information / information: E-mail: info@webermt.de</p> <p>Ersatzteile / spare parts: E-mail: parts@webermt.de</p>	<p>Telefon / phone:</p> <p>Telefax / fax:</p> <p>Telefax / fax:</p>	<p>+49 (0) 2754 / 3980 Zentrale / switchboard</p> <p>+49 (0) 2754 / 398101 Zentrale / switchboard</p> <p>+49 (0) 2754 / 398102 Ersatzteile / spare parts direct dial</p>
<p>In Holland</p> <p>In Netherlands</p>	<p>WEBER Maschinenteknik B.V. Graafschap Hornelaan 159 6001 AC Weert</p> <p>E-mail: info@webermt.nl</p>	<p>Telefon / phone:</p> <p>Telefax / fax:</p>	<p>+31 (0) 495 / 530215</p> <p>+31 (0) 495 / 541839</p>
<p>In Frankreich</p> <p>In France</p>	<p>WEBER Technologie S.A.R.L. 26, rue d'Arsonval 69680 Chassieu</p> <p>E-mail: france@webermt.com</p>	<p>Telefon / phone:</p> <p>Telefax / fax:</p>	<p>+33 (0) 472 / 791020</p> <p>+33 (0) 472 / 791021</p>
<p>In Polen</p> <p>In Poland</p>	<p>WEBER Maschinenteknik SP.ZO.O. ul. Grodziska 7 05-830 Stara Wies / Nadarzyn</p> <p>E-mail: info@webermt.com.pl</p>	<p>Telefon / phone:</p> <p>Telefax / fax:</p>	<p>+48 (0) 22 / 7397080 +48 (0) 22 / 7397081</p> <p>+48 (0) 22 / 7397082</p>
<p>In USA, Kanada</p> <p>In USA, Canada</p>	<p>WEBER Machine (USA), Inc. 40 Johnson Ave 112 Bangor, ME 04401 USA</p> <p>E-mail: usa@webermt.com</p>	<p>Telefon / phone:</p> <p>Telefax / fax:</p>	<p>+1 (0) 207 / 9474990</p> <p>+1 (0) 207 / 9475452</p>
<p>In Südamerika</p> <p>In South America</p>	<p>WEBER Maschinenteknik do Brasil Ltda. Rua Sete de Setembro, 275 93332-470 Novo Hamburgo, RS Brasil</p> <p>E-mail: webermt@webermt.com.br</p>	<p>Telefon / phone:</p> <p>Telefax / fax:</p>	<p>+55 (0) 51 / 5873044</p> <p>+55 (0) 51 / 5872271</p>

<http://www.webermt.com>

