



ERSATZTEILLISTE

SPARE PARTS LIST

**LISTE DES PIECES
DE RECHANGE**

LISTINO RICAMBI

LISTA DE RECAMBIOS

**WYKAZ CZESCI
ZAMIENNYCH**



CR 3



03.2008

0116121-0116129

Ab Masch.-Nr. 7012314

Weber Maschinenteknik GmbH
Postfach 2153, 57329 Bad Laasphe-Rückershausen
Telefon 02754 / 398-0
Telefax (02754) 398-101 (Zentrale) u. 398-102 (Ersatzteile)

EG - KONFORMITÄTSERKLÄRUNG

EC DECLARATION OF CONFORMITY/ DECLARATION DE CONFORMITE CE
DICHIARAZIONE CE DI CONFORMITA / DECLARACION CE DE CONFORMIDAD
EG-VERKLARING VAN OVEREENSTEMMING / EF-OVERENSSTEMMELSESERKAERING
DECLARACAO CE DE CONFORMIDADE / EG-FÖRSÄKRAN OM ÖVERENSSTÄMMELSE
DEKLARACJA ZGODNOŚCI

im Sinne der EG-Maschinenrichtlinie 98/37/EG und der EG Richtlinie 2000/14/EG – Geräuschemissionen

- I **Hersteller/** Make / Marque / Marca / Marca / Producent / Merk / Marca /
Tillverkare / Producent **Weber Maschinentechnik GmbH**
Im Boden 5-8,10
57334 Bad Laasphe
- II **Art /** Category / Catégorie / Categoria Tipo / Kategori /
Soort / Categoria / kategori / Typ **Vibrationsplatte**
- III **Typ /** Type / Type / Tipo / Codice / Type / Type / Tipo / Typ /
CR 3 , CR 3 E
- IV **Nennleistung /** Nominal-performance / La puissance nominale / Prestazione nominale /
Potencia nominal / Nominaal vermogen / Nominel ydelse / Potência nominal / Nominell
effect / Moc **P = 3,1 kW**
- V **gemessener Schalleistungspegel /** measured sound power level / niveau de
puissance acoustique mesurée / livello di potenza sonora rilevato / nivel de potencia
acústica medido / gemeten geluidsvermogensniveau / målt lydeffektniveau / Nivel de
potência sonora medido / uppmätt ljudeffektnivå / Mierzony poziom dźwięku
LWA = 106 dB (A)
- VI **garantierter Schalleistungspegel /** guaranteed sound power level / niveau de
puissance acoustique garanti / livello di potenza sonora garantito / nivel de potencia
acustica garantizado / gewaarborgd geluidsvermogensniveau / garanteret lydeffektniveau /
Nivel sonoro garantido / garanterad ljudeffektnivå / Natężenie hałas
LWA = 108 dB (A)
- VII **beteiligte Zertifizierungsstelle /** notified body involved / de l'organisme notifié/
dell'organismo notificato che l'ha effettuata / dirección del organismo notificado que haya
intervenido / betrokken aangemelde instantie / pagældende bemyndigede organ /
organismo notificado involucrado / berörda anmälda organets namn / Jednostka
certyfikująca **RWTÜV**
Postfach 103161
D-45032 Essen
- VIII **Konformitäts-Bewertungsverfahren /** Conformity assessment procedure followed /
la procédure appliquée pour l'évaluation de la conformité et / procedura di valutazione
della conformità / procedimiento de evaluación de la conformidad / gevolgde
overeenstemmingsbeoordelingsprocedure / den fulgte
overensstemmelsesvurderingsprocedure / procedimento de avaliação de conformidade
/ Vilket förfarande för bedömning av överensstämmelse / Przebieg kontroli **interne Fertigungskontrolle**
nach Anhang VI
EG Richtlinie 2000/14/EG

ist in Übereinstimmung mit folgenden Richtlinien hergestellt worden / has been produced in accordance with following standards / est produit conforme aux dispositions des directives européennes ci-apres / ha sido fabricado en conformidad con las siguientes normas / é stato fabbricato in conformità alle sequenti norme / er blevet fremstillet i overensstemmelse med følgende retningslinier / in overensstemming met de volgende voorschriften gefabriceerd is / é fabricado conforme as seguintes normas / har tillverkats i överensstämmelse med följande riktlinjer / Zgodność z obowiązującymi przepisami

98/37/EG Maschinenrichtlinie des europäischen Parlamentes und des Rates vom 22. Juni 1998
2000/14/EG EG-Richtlinie Geräuschemissionen vom 8. Mai 2000
2005/88/EG EG-Richtlinie vom 14. Dez. 2005 zur Änderung der Richtlinie 2000/14/EG
EN 500 Teil 1 Bewegliche Straßenbaumaschinen – Sicherheit
Gemeinsame Anforderungen
EN 500 Teil 4 Bewegliche Straßenbaumaschinen – Sicherheit
Besondere Anforderungen an Verdichtungsmaschinen

Bescheinigung bitte sorgfältig aufbewahren / File certificate carefully / Conserver certificat soigneusement / Conserver certificado cuidadosamente / Pregasi conservare accuratamente certificato / Beviset bedes opbevares omhyggeligt / Verklaring a.u.b. zorgvuldig bevar / Conserver o certificado com cuidado / Beviset skall om sorgsfullt bevaras // Deklarację zgodności proszę zachować

Bad Laasphe – Rückershausen, den **02.01.2008**

W. Weber, Geschäftsführer

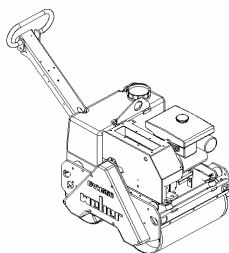

WEBER Maschinentechnik GmbH
Im Boden 5-8, 10 – D-57334 Bad Laasphe
Postfach 2153 – D-57329 Bad Laasphe
Telefon: 02754/398-0 – Fax 02754/398-101
E-mail: Verkauf@webermt.de
Internet: <http://www.webermt.de>



EG - KONFORMITÄTSERKLÄRUNG

EC DECLARATION OF CONFORMITY / DECLARATION DE CONFORMITE CE
DICHIARAZIONE CE DI CONFORMITA / DECLARACION CE DE CONFORMIDAD
EG-VERKLARING VAN OVEREENSTEMMING / EF-OVERENSSTEMMELSESERKAERING
DECLARACAO CE DE CONFORMIDADE / EG-FÖRSÄKRAN OM ÖVERENSSTÄMMELSE
DEKLARACJA ZGODNOŚCI

im Sinne der EG-Maschinenrichtlinie 98/37/EG
und der EG Richtlinie 2000/14/EG – Geräuschemissionen

- I **Hersteller/** Make / Marque / Marca / Marca / Producent / Merk / Marca /
Tillverkare / Producent **Weber Maschinentechnik GmbH**
Im Boden 5-8,10
57334 Bad Laasphe
- II **Art /** Category / Catégorie / Categoria Tipo / Kategori /
Soort / Categoria / kategori / Typ **Vibrationsplatte**
- III **Typ /** Type / Type / Tipo / Codice / Type / Type / Tipo / Typ / **CR 3 Hd**
- IV **Nennleistung /** Nominal-performance / La puissance nominale / Prestazione nominale /
Potencia nominal / Nominaal vermogen / Nominel ydelse / Potência nominal / Nominell
effect / Moc **P = 6,1 kW**
- V **gemessener Schalleistungspegel /** measured sound power level / niveau de
puissance acoustique mesure / livello di potenza sonora rilevato / nivel de potencia
acústica medido / gemeten geluidsvermogensniveau / målt lydeffektniveau / Nivel de
potência sonora midido / uppmått ljudeffektnivå / Mierzony poziom dźwięku **LWA = 106 dB (A)**
- VI **garantierter Schalleistungspegel /** guaranteed sound power level / niveau de
puissance acoustique garanti / livello di potenza sonora garantito / nivel de potencia
acustica garantizado / gewaarborgd geluidsvermogensniveau / garanteret lydeffektniveau /
Nivel sonoro garantido / garanterad ljudeffektnivå / Natężenie hałasu **LWA = 108 dB (A)**
- VII **beteiligte Zertifizierungsstelle /** notified body involved / de l'organisme notifié/
dell'organismo notificato che l'ha effettuata / dirección del organismo notificado que haya
intervenido / betrokken aangemelde instantie / pågældende bemyndigede organ /
organismo notificado involucrado / berörda anmälda organets namn / Jednostka
certyfikująca **RWTÜV**
Postfach 103161
D-45032 Essen
- VIII **Konformitäts-Bewertungsverfahren /** Conformity assessment procedure followed /
la procédure appliquée pour l'évaluation de la conformité et / procedura di valutazione
della conformità / procedimiento de evaluación de la conformidad / gevolgde
overeenstemmingsbeoordelingsprocedure / den fulgte
overensstemmelssesvurderingsprocedure / procedimento de avaliacao de conformidade
/ Vilket förfarande för bedömning av överensstämmelse / Przebieg kontroli **interne Fertigungskontrolle**
nach Anhang VI
EG Richtlinie 2000/14/EG

ist in Übereinstimmung mit folgenden Richtlinien hergestellt worden / has been produced in accordance with following standards / est produit conforme aux dispositions des directives européennes ci-apres / ha sido fabricado en conformidad con las siguientes normas / é stato fabbricato in conformità alle seguenti norme / er blevet fremstillet i overensstemmelse med følgende retningslinier / in overeenstemming met de volgende voorschriften gefabriceerd is / é fabricado conforme as seguintes normas / har tillverkats i överensstämmelse med följande riktlinjer / Zgodność z obowiązującymi przepisami

98/37/EG Maschinenrichtlinie des europäischen Parlamentes und des Rates vom 22. Juni 1998
2000/14/EG EG-Richtlinie Geräuschemissionen vom 8. Mai 2000
2005/88/EG EG-Richtlinie vom 14. Dez. 2005 zur Änderung der Richtlinie 2000/14/EG
EN 500 Teil 1 Bewegliche Straßenbaumaschinen – Sicherheit
Gemeinsame Anforderungen
EN 500 Teil 4 Bewegliche Straßenbaumaschinen – Sicherheit
Besondere Anforderungen an Verdichtungsmaschinen

Bescheinigung bitte sorgfältig aufbewahren / File certificate carefully / Conserver certificat soigneusement / Conservar certificado cuidadosamente / Pregasi conservare accuratamente certificato / Beviset bedes opbevares omhyggeligt / Verklaring a.u.b. zorgvuldig bevar / Conservar o certificado com cuidado / Beviset skall om sorgsfullt bevaras // Deklarację zgodności proszę zachować

Bad Laasphe – Rückershausen, den **02.01.2008**

W. Weber, Geschäftsführer

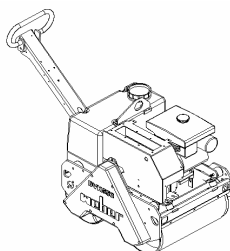

weberm

WEBER Maschinentechnik GmbH
Im Boden 5-8, 10 – D-57334 Bad Laasphe
Postfach 2153 – D-57329 Bad Laasphe
Telefon: 02754/398-0 – Fax 02754/398-101
E-mail: Verkauf@webermt.de
Internet: <http://www.webermt.de>



BITTE, NOTIEREN SIE SERIENNUMMER UND MOTORNUMMER IHRER MASCHINE:

PLEASE WRITE DOWN SERIALNUMBERS OF MACHINE AND ENGINE:

NOTEZ SVP LE NUMERO DE SERIE ET LE NUMERO DU MOTEUR DE VOTRE MACHINE:

SI PREGA DI ANNOTARE SEMPRE I NUMERI DI SERIE SIA DELLA VS. MACCHINA CHE DEL MOTORE:

MAQUINA: ROGAMOS ANOTEN EL NUMERO DE SERIE Y NUMERO DE MOTOR DE SU MAQUINA:

MASCHINE
MACHINE
MACCHINA
MAQUINA

#

MOTOR
ENGINE
MOTEUR
MOTORE

#

ZUR VERMEIDUNG VON FEHLLIEFERUNGEN UND VERZÖGERUNGEN SIND BEI DER BESTELLUNG VON ERSATZTEILEN FOLGENDE ANGABEN UNBEDINGT ERFORDERLICH:

- MASCHINENTYP
- SERIENNUMMER DER MASCHINE
- SERIENNUMMER DES MOTORS (BEI MOTORTEILEN)
- TEILENUMMER
- BESTELLMENGE

TO AVOID ERRORS IN DELIVERY PLEASE STATE THESE PARTICULARS WHEN ORDERING:

- TYPE OF MACHINE
- SERIAL NO. OF MACHINE
- SERIAL NO. OF ENGINE (ON ENGINE PARTS)
- PART-NO.
- QUANTITY REQUIRED

AFIN D'EVITER DES ERREURS DE COMMANDE ET DES RETARDS DE LIVRAISON IL EST NECESSAIRE D'INDIQUER LES CARACTERISTIQUES SUIVANTES:

- TYPE DE MACHINE
- LE NUMERO DE SERIE DE LA MACHINE
- LE NUMERO DE SERIE DU MOTEUR
- LE NUMERO D'IDENTITE DE LA PIECE
- LA QUANTITE SOUHAITEE

ONDE EVITARE DISGUIDI E RITARDI NELLE CONSEGNE DIE RICAMBI SI PREGA DI INDICARE SEMPRE:

- TIPO DELLA MACCHINA
- NUMERO DI SERIE DELLA MACCHINA
- NUMERO DI SERIE DEL MOTORE (SE SI RICHIEDONO PEZZI DEL MOTORE)
- NUMERO D'ORDINE DIE SINGOLI RICAMBI
- QUANTITA

A FI DE EVITAR ERRORES DE ENTREGA, ROGAMOS INDIQUEN LOS SIGUIENTES DATOS CUANDO PASE PEDIDOS DE RECAMBIO:

- MODELO DE MAQUINA
- NO. DE SERIE DE LA MAQUINA
- NO. DE SERIE DEL MOTOR (EN PIEZAS PARA MOTOR)
- REFERENCIA DEL RECAMBIO
- CANTIDAD PEDIDA

E 3257-0907

Position Ref.No. Repère Posizione Posicion	Menge Quantity Quantité Quantita Cantidad	Teile-Nr. Part-No. No. Référence Nr. d'Ordine No. Referenzia	Hinweis Hints Indications Indicazione Indicaciones	Position Ref. No. Repère Posizione Posicion	Menge Quantity Quantité Quantita Cantidad	Teile-Nr. Part-No. No. Référence Nr. d'Ordine No. Referenzia	Hinweis Hints Indications Indicazione Indicaciones
1	1	11000337		41	1	21000228	
2	1	20013302		42	1	25034018	DIN471-A75x2,5
3	1	11000374		43	1	25001045	
4	10	25040027	DIN931-M8x35	44	1	25035003	DIN472-I62x2
5	10	20029024		45	1	11000346	
6	1	25034020	DIN471-A38x1,75	46	2	25001103	
7	4	25038023	DIN933-M16x25	47	1	11000352	
8	4	20029002	VSK 16	48	1	11000355	
9	1	11000377		49	1	25027004	DIN914-M8x16
10	3	25038006	DIN933-M8x16	50	1	25035026	DIN472-I28x1,2
11	3	20029003	VSK 8	51	1	25001513	
12	1	11000349		52	1	25034002	DIN471-A12
13	2	25044008	DIN912-M8x40	53	1	10016066	
14	2	25044046	DIN912-M8x55	54	1	20013270	
15	4	20029011	VSKZ 8	55	1	21000290	
16	2	10016060		56	1	25048003	DIN125-A10,5
17	2	20013269		57	1	25035011	DIN472-I20
18	8	25044100	DIN912-M8x16	58	1	11000351	
19	8	20029011	VSKZ 8	59	1	11000350	
20	1	10016061		60	2	21000358	DIN912-M10x40-10.9
21	1	20013269		61	2	25025245	
22	4	25044100	DIN912-M8x16	62	1	11000347	
23	4	20029011	VSKZ 8	63	1	25015016	
24	1	11000348		64	2	25001103	
25	1	20013269		65	1	25017047	
26	4	25044100	DIN912-M8x16	66	1	11000356	
27	4	20029011	VSKZ 8	67	1	10007370	
28	1	20020119		68	1	10016071	
29	1	25030016	DIN910-M10x1	69	1	20029001	VSK 10
30	1	25008012	DIN7603-10x16x1	70	1	25034006	DIN471-A35x1,5
31	1	25030002	DIN908-M14x1,5	71	1	20007066	
32	4	20004062		72	1	25038007	DIN933-M8x20
33	4	11000378		73	1	20029024	
34	4	20029023	SKB 12	74	1	25049026	DIN7349-8,4
35	4	25031005	DIN934-M12				
36	1	11000353					
37	1	11000354					
38	2	21000358	DIN912-M10x40-10.9				
39	2	25025245					
40	1	11000345					

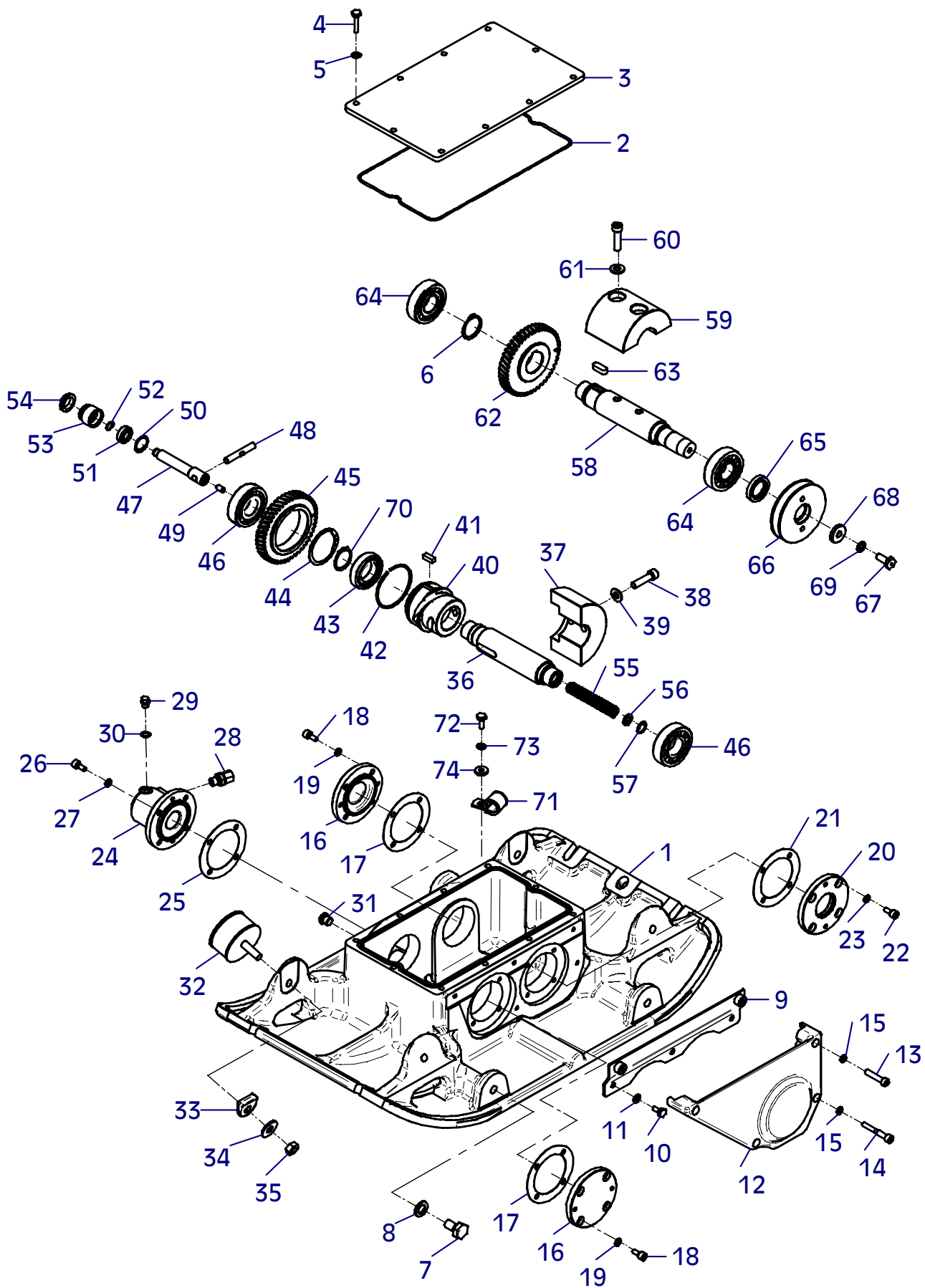

E 3257-0907

E 3258-0308

Position Ref.No. Repère Posizione Posicion	Menge Quantity Quantité Cantidad	Teile-Nr. Part-No. No. Référence Nr. d'Ordine No. Referenzia	Hinweis Hints Indications Indicazione Indicaciones	Position Ref. No. Repère Posizione Posicion	Menge Quantity Quantité Cantidad	Teile-Nr. Part-No. No. Référence Nr. d'Ordine No. Referenzia	Hinweis Hints Indications Indicazione Indicaciones
1	1	11000406					
2	4	25038019	DIN933-M12x25				
3	4	20029023	SKB 12				
4	1	11000442					
5	4	25038021	DIN933-M12x35				
6	4	25031027	DIN1587-M12				
7	1	11000464					
8	4	25038007	DIN933-M8x20				
9	4	20029021	SKB 8				
10	1	20026481					
11	2	25025191	DIN80705-M20x1,5				
12	2	20025019					
13	1	10017337					
14	2	21000031					
15	2	11000148					
16	2	25040022	DIN931-M16x70				
17	2	25031017	DIN985-M16				
18	1	11000496					
19	1	25033030	ISO7380-M6x20-10.9				
20	1	25049034	DIN7349-6,4				
21	1	25048001	DIN125-A6,4				
22	1	25031012	DIN985-M6				
23	1	25040012	DIN931-M10x55				
24	1	25048003	DIN125-A10,5				
25	1	20029001	VSK 10				
26	1	25031004	DIN934-M10				
27	8	20029023	SKB 12				

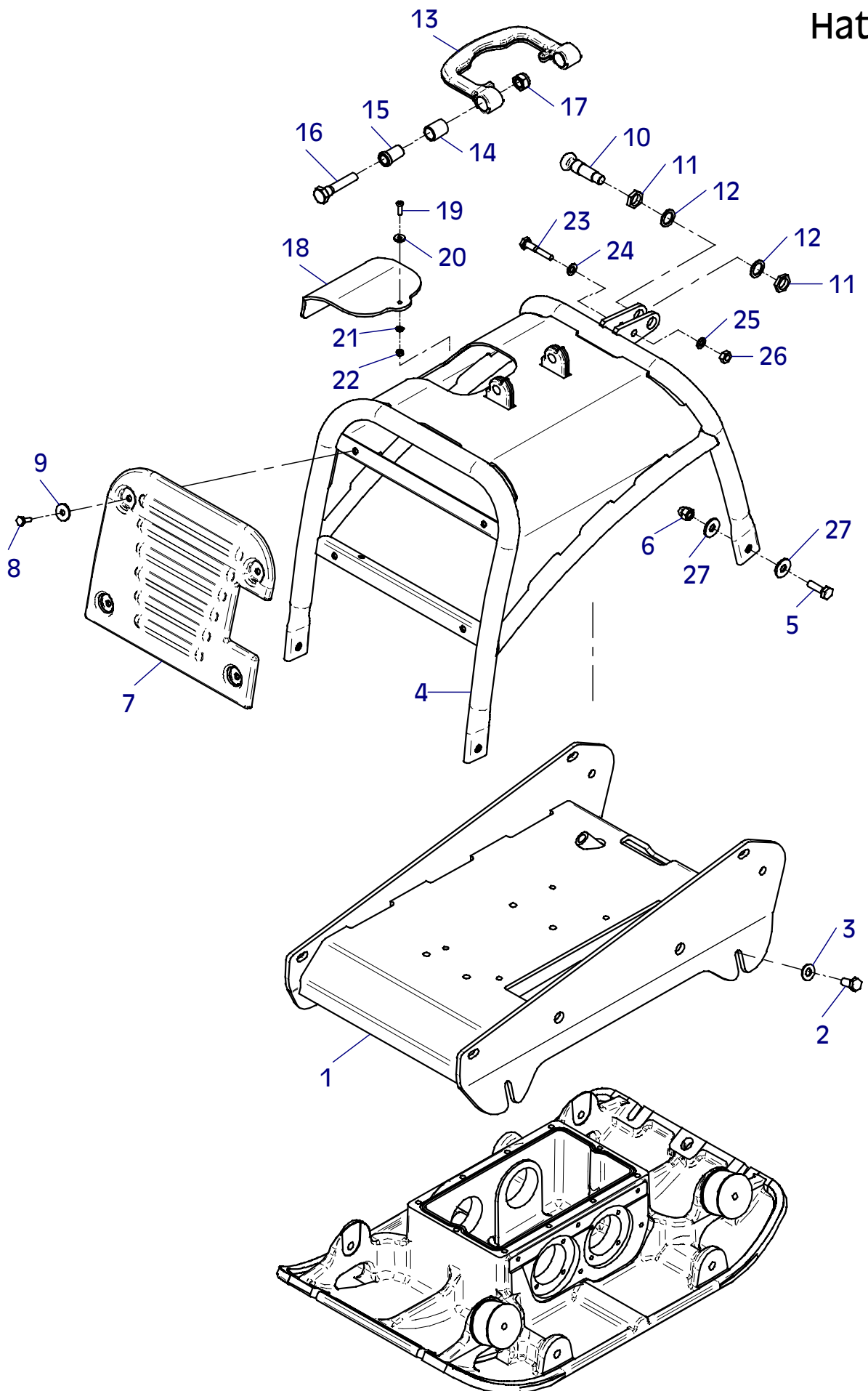

E 3264-0308

Position Ref.No. Repère Posizione Posicion	Menge Quantity Quantité Cantidad	Teile-Nr. Part-No. No. Référence Nr. d'Ordine No. Referenzia	Hinweis Hints Indications Indicazione Indicaciones	Position Ref. No. Repère Posizione Posicion	Menge Quantity Quantité Cantidad	Teile-Nr. Part-No. No. Référence Nr. d'Ordine No. Referenzia	Hinweis Hints Indications Indicazione Indicaciones
1	1	11000411					
2	4	25038019	DIN933-M12x25				
3	4	20029023	SKB 12				
4	1	11000442					
5	4	25038021	DIN933-M12x35				
6	2	25031027	DIN1587-M12				
7	1	11000464					
8	4	25038007	DIN933-M8x20				
9	4	20029021	SKB 8				
10	1	20026481					
11	2	25025191	DIN80705-M20x1,5				
12	2	20025019					
13	1	10017337					
14	2	21000031					
15	2	11000148					
16	2	25040022	DIN931-M16x70				
17	2	25031017	DIN985-M16				
18	1	11000496					
19	1	25033030	ISO7380-M6x20-10.9				
20	1	25049034	DIN7349-6,4				
21	1	25048001	DIN125-A6,4				
22	1	25031012	DIN985-M6				
23	1	25040012	DIN931-M10x55				
24	1	25048003	DIN125-A10,5				
25	1	20029001	VSK 10				
26	1	25031004	DIN934-M10				
27	6	20029023	SKB 12				

Hatz

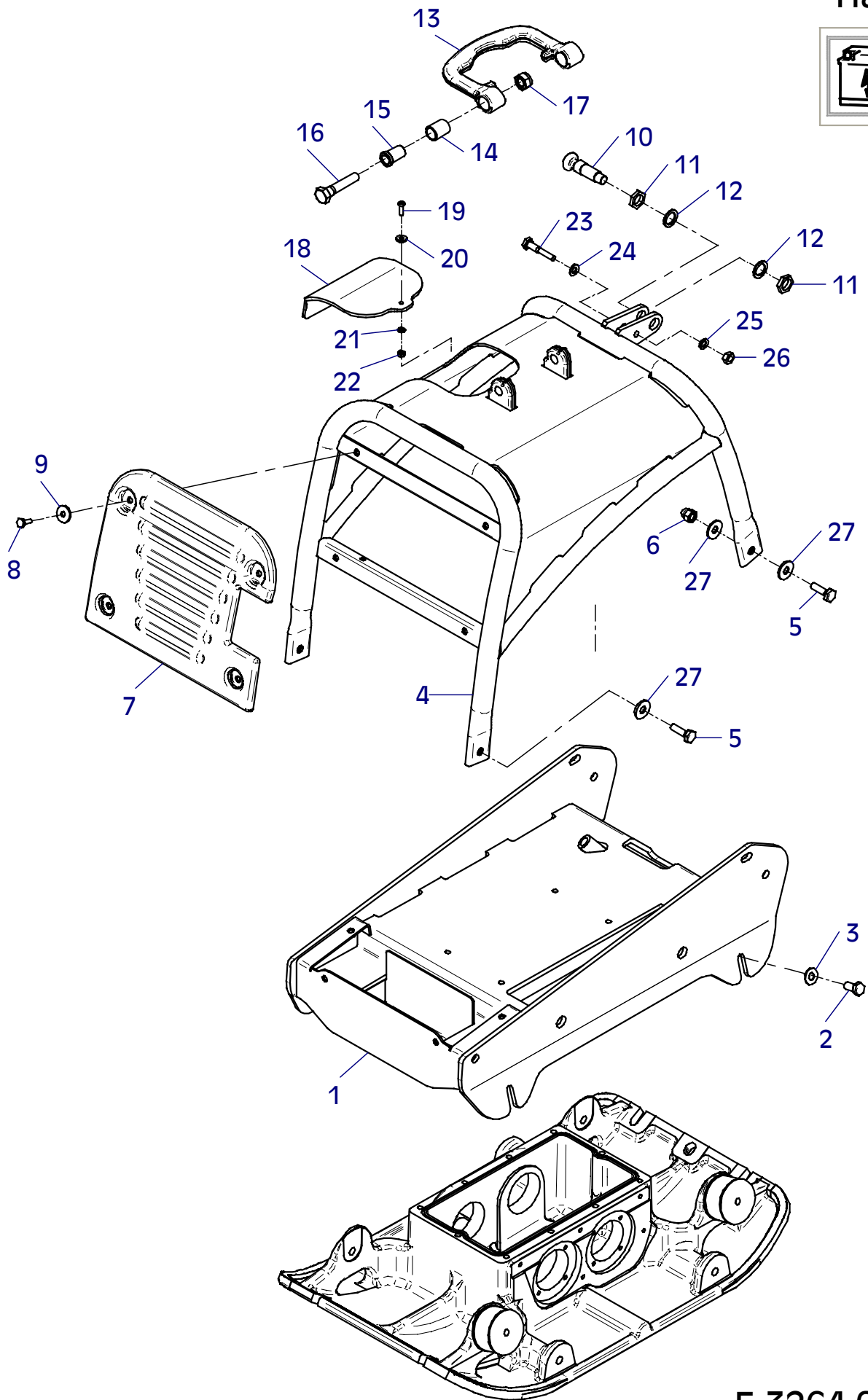
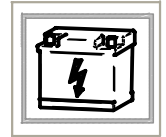

E 3264-0308

E 3259-0907

Position Ref.No. Repère Posizione Posicion	Menge Quantity Quantité Quantità Cantidad	Teile-Nr. Part-No. No. Référence Nr. d'Ordine No. Referenzia	Hinweis Hints Indications Indicazione Indicaciones	Position Ref. No. Repère Posizione Posicion	Menge Quantity Quantité Quantità Cantidad	Teile-Nr. Part-No. No. Référence Nr. d'Ordine No. Referenzia	Hinweis Hints Indications Indicazione Indicaciones
1	1	21000327					
2	4	25038009	DIN933-M8x30				
3	4	20029024					
4	4	25031003	DIN934-M8				
5	1	11000545					
6	4	20022013	Tensilock M10x20				
7	1	21000242					
8	1	25002179					
9	1	21000044	DIN912-M8x45-12.9				
10	1	20029003	VSK 8				
11	1	20026475					
12	1	11000544					
13	4	25044009	DIN912-M8x45				
14	4	20029011	VSKZ 8				
15	1	11000561					
16	1	20007086					
17	1	21000334					
18	1	25008017	DIN7603-22x27x1,5				
19	1	21000332					
20	2	25048001	DIN125-A6,4				
21	2	25031002	DIN934-M6				
22	2	20025060					
23	1	40031336					
24	1	40031334					
25	4	25048002	DIN125-A8,4				

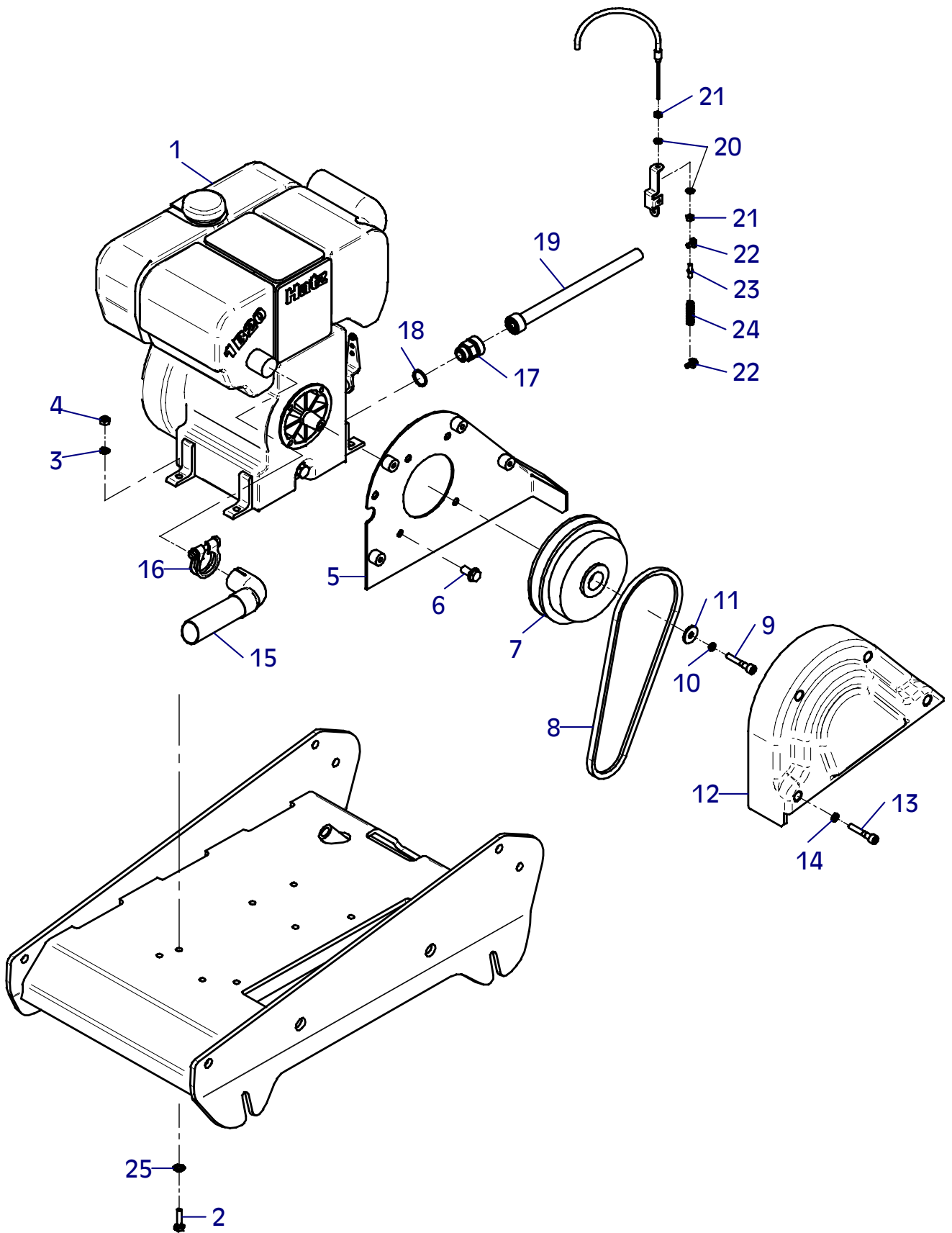

E 3268-0907

Position Ref.No. Repère Posizione Posicion	Menge Quantity Quantité Quantita Cantidad	Teile-Nr. Part-No. No. Référence Nr. d'Ordine No. Referenzia	Hinweis Hints Indications Indicazione Indicaciones	Position Ref. No. Repère Posizione Posicion	Menge Quantity Quantité Quantita Cantidad	Teile-Nr. Part-No. No. Référence Nr. d'Ordine No. Referenzia	Hinweis Hints Indications Indicazione Indicaciones
1	1	21000328	E				
1	1	21000346	E-EPA				
2	3	25038009	DIN933-M8x30				
3	4	20029024					
4	4	25031003	DIN934-M8				
5	1	11000545					
6	4	20022013	Tensilock M10x20				
7	1	21000242					
8	1	25002179					
9	1	21000044	DIN912-M8x45-12.9				
10	1	20029003	VSK 8				
11	1	20026475					
12	1	11000544					
13	4	25044009	DIN912-M8x45				
14	4	20029011	VSKZ 8				
15	1	11000561					
16	1	20007086					
17	1	21000334					
18	1	25008017	DIN7603-22x27x1,5				
19	1	21000332					
20	2	25048001	DIN125-A6,4				
21	2	25031002	DIN934-M6				
22	2	20025060					
23	1	40031336					
24	1	40031334					
25							
26	4	25048002	DIN125-A8,4				
27	1	25038011	DIN933-M8x40				
28	2	25048002	DIN125-A8,4				
29	1	25031013	DIN985-M8				

Hatz

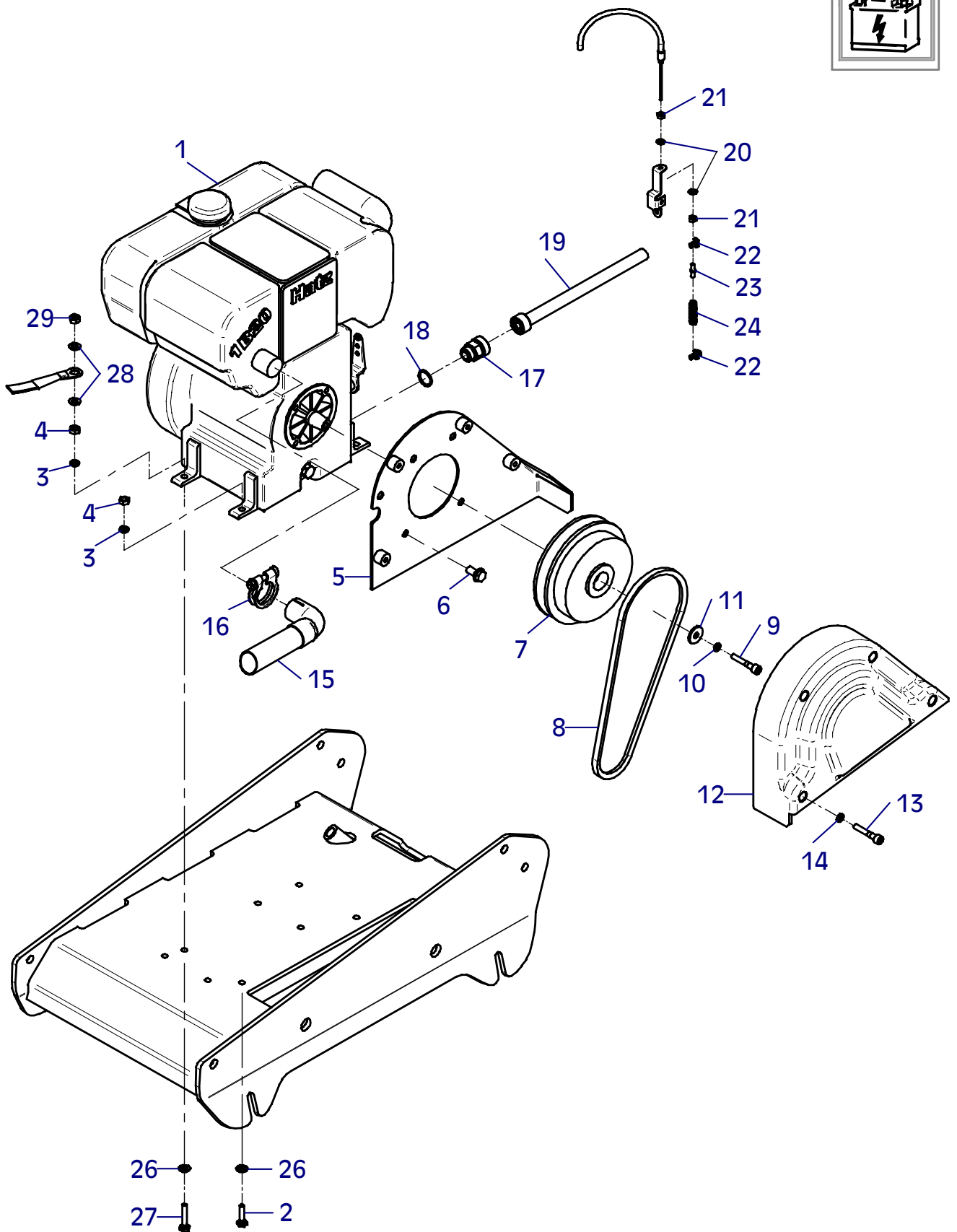
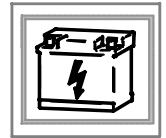

E 3268-0907

E 3260-0407

Position Ref.No. Repère Posizione Posicion	Menge Quantity Quantité Quantita Cantidad	Teile-Nr. Part-No. No. Référence Nr. d'Ordine No. Referenzia	Hinweis Hints Indications Indicazione Indicaciones	Position Ref. No. Repère Posizione Posicion	Menge Quantity Quantité Quantita Cantidad	Teile-Nr. Part-No. No. Référence Nr. d'Ordine No. Referenzia	Hinweis Hints Indications Indicazione Indicaciones
1	1	21000242					
2	2	20002548					
3	2	20002269					
4	2	21000151					
5	3	21000019					

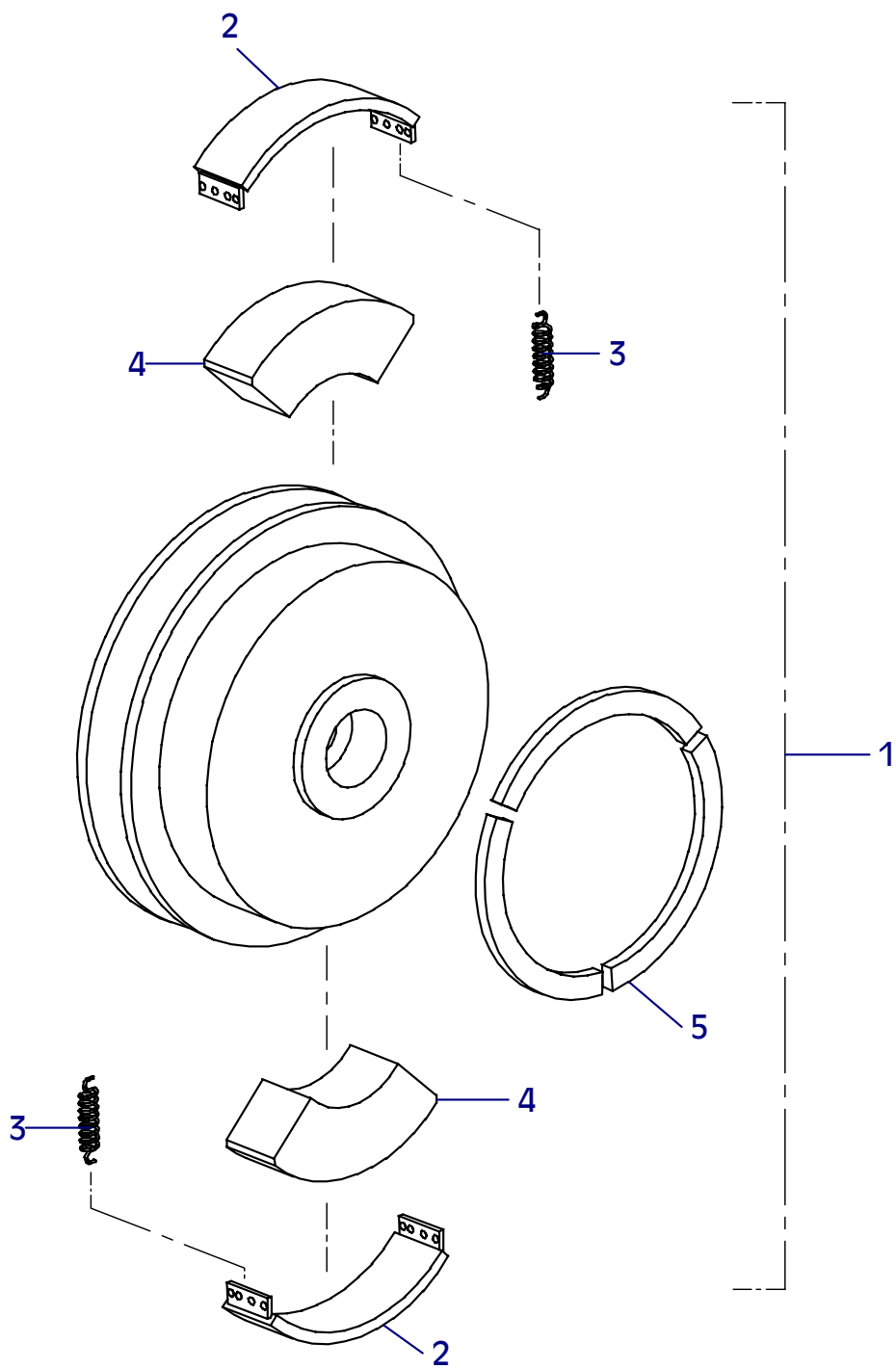

E 3260-0407

E 3265-0408

Position Ref.No. Repère Posizione Posicion	Menge Quantity Quantité Cantidad	Teile-Nr. Part-No. No. Référence Nr. d'Ordine No. Referenzia	Hinweis Hints Indications Indicazione Indicaciones	Position Ref. No. Repère Posizione Posicion	Menge Quantity Quantité Cantidad	Teile-Nr. Part-No. No. Référence Nr. d'Ordine No. Referenzia	Hinweis Hints Indications Indicazione Indicaciones
1	1	20031558					
2	1	11000597					
3	2	11000596					
4	2	11000595					
5	1	11000594					
6	1	11000627					
7	1	10001457					
8	1	11000470					
9	4	25038006	DIN933-M8x16				
10	4	20029021	SKB 8				
11	1	21000354					

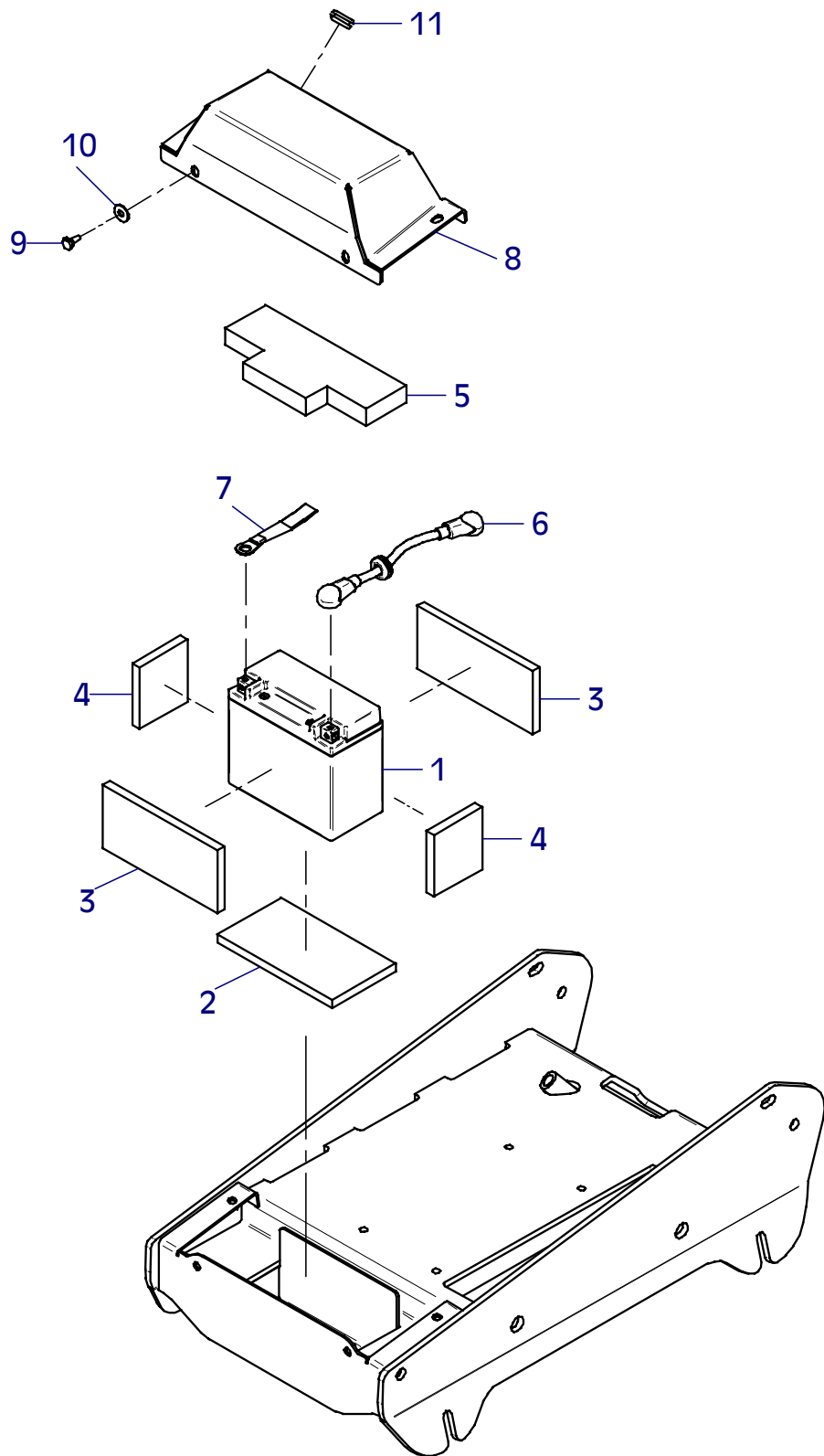

E 3265-0408

E 3262-0308

Position Ref.No. Repère Posizione Posicion	Menge Quantity Quantité Quantita Cantidad	Teile-Nr. Part-No. No. Référence Nr. d'Ordine No. Referenzia	Hinweis Hints Indications Indicazione Indicaciones	Position Ref. No. Repère Posizione Posicion	Menge Quantity Quantité Quantita Cantidad	Teile-Nr. Part-No. No. Référence Nr. d'Ordine No. Referenzia	Hinweis Hints Indications Indicazione Indicaciones
1	1	11000406					
2	4	25038019	DIN933-M12x25				
3	4	20029023	SKB 12				
4	1	11000422					
5	4	25038021	DIN933-M12x35				
6	4	25031027	DIN1587-M12				
7	1	11000530					
8	4	25038007	DIN933-M8x20				
9	4	20029021	SKB 8				
10	1	20026481					
11	2	25025191	DIN80705-M20x1,5				
12	2	20025019					
13	1	10017337					
14	2	21000031					
15	2	11000148					
16	2	25040022	DIN931-M16x70				
17	2	25031017	DIN985-M16				
18	1	25040012	DIN931-M10x55				
19	1	25048003	DIN125-A10,5				
20	1	20029001	VSK 10				
21	1	25031004	DIN934-M10				
22	8	20029023	SKB 12				

Honda

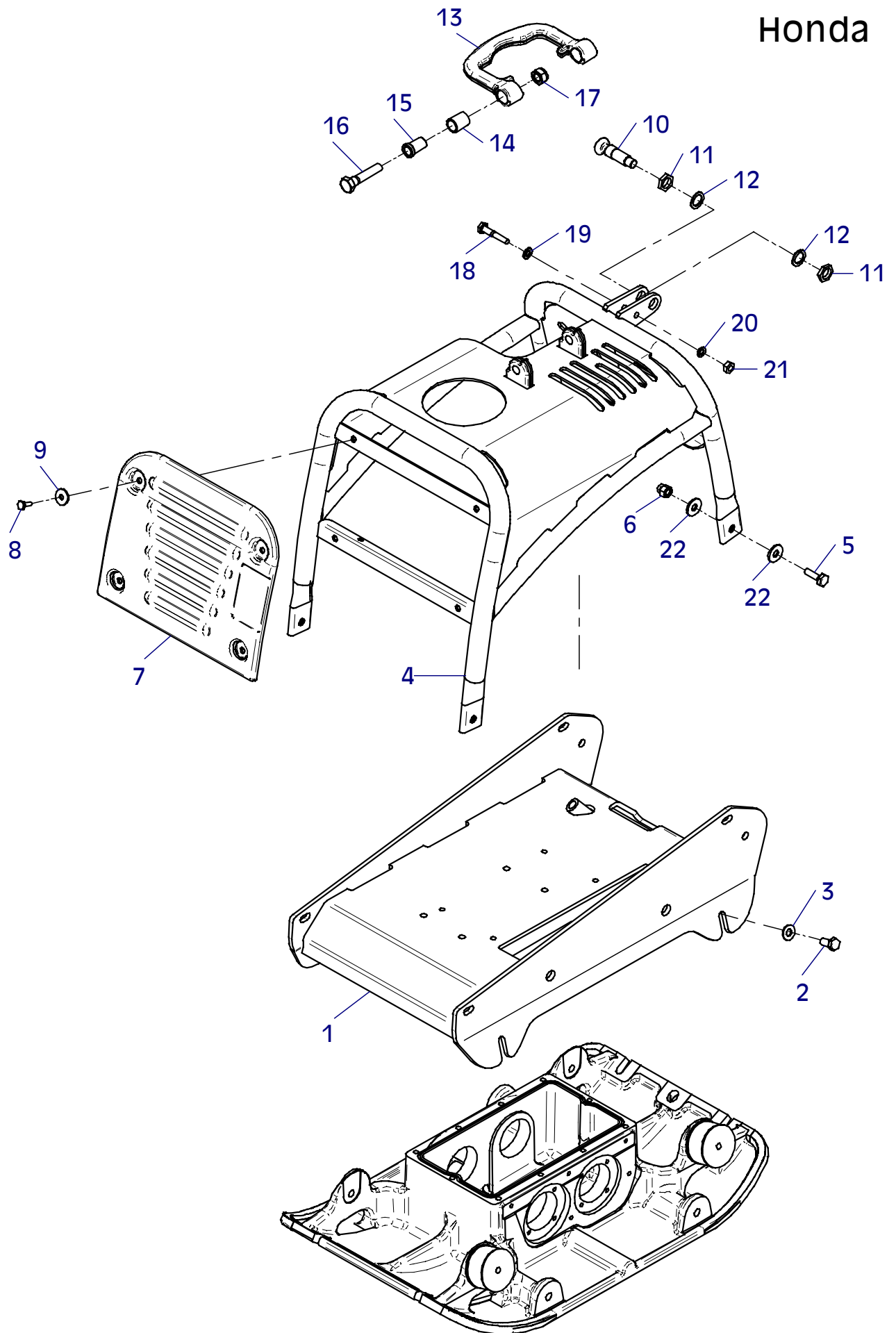

E 3262-0308

E 3263-0308

Position Ref.No. Repère Posizione Posicion	Menge Quantity Quantité Cantidad	Teile-Nr. Part-No. No. Référence Nr. d'Ordine No. Referenzia	Hinweis Hints Indications Indicazione Indicaciones	Position Ref. No. Repère Posizione Posicion	Menge Quantity Quantité Cantidad	Teile-Nr. Part-No. No. Référence Nr. d'Ordine No. Referenzia	Hinweis Hints Indications Indicazione Indicaciones
1	1	20001230		31	1	25031003	DIN934-M8
2	2	10016212		32	1	11000577	
3	4	25040012	DIN931-M10x55	33	1	20026384	
4	4	25048003	DIN125-A10,5	34	2	20026389	
5	4	20029025		35	1	20026580	
6	4	25031004	DIN934-M10				
7	1	11000547					
8	4	25047017	DIN7991-M8x20				
9	4	25005003	DIN6798-V8,4				
10	1	21000323					
11	1	10016954					
12	1	21000344					
13	1	11000593					
14	1	25044007	DIN912-M8x30				
15	1	20029011	VSKZ 8				
16	1	11000544					
17	4	25044009	DIN912-M8x45				
18	4	20029011	VSKZ 8				
19	1	25008011	DIN7603-12x18x1,5				
20	1	20026204					
21	1	20025704					
22	1	20026383					
23	1	21000335					
24	1	20007007					
25	1	25038002	DIN933-M6x16				
26	1	20029007	VSK 6				
27	1	25048001	DIN125-A6,4				
28	1	11000576					
29	1	25038006	DIN933-M8x16				
30	2	25048002	DIN125-A8,4				

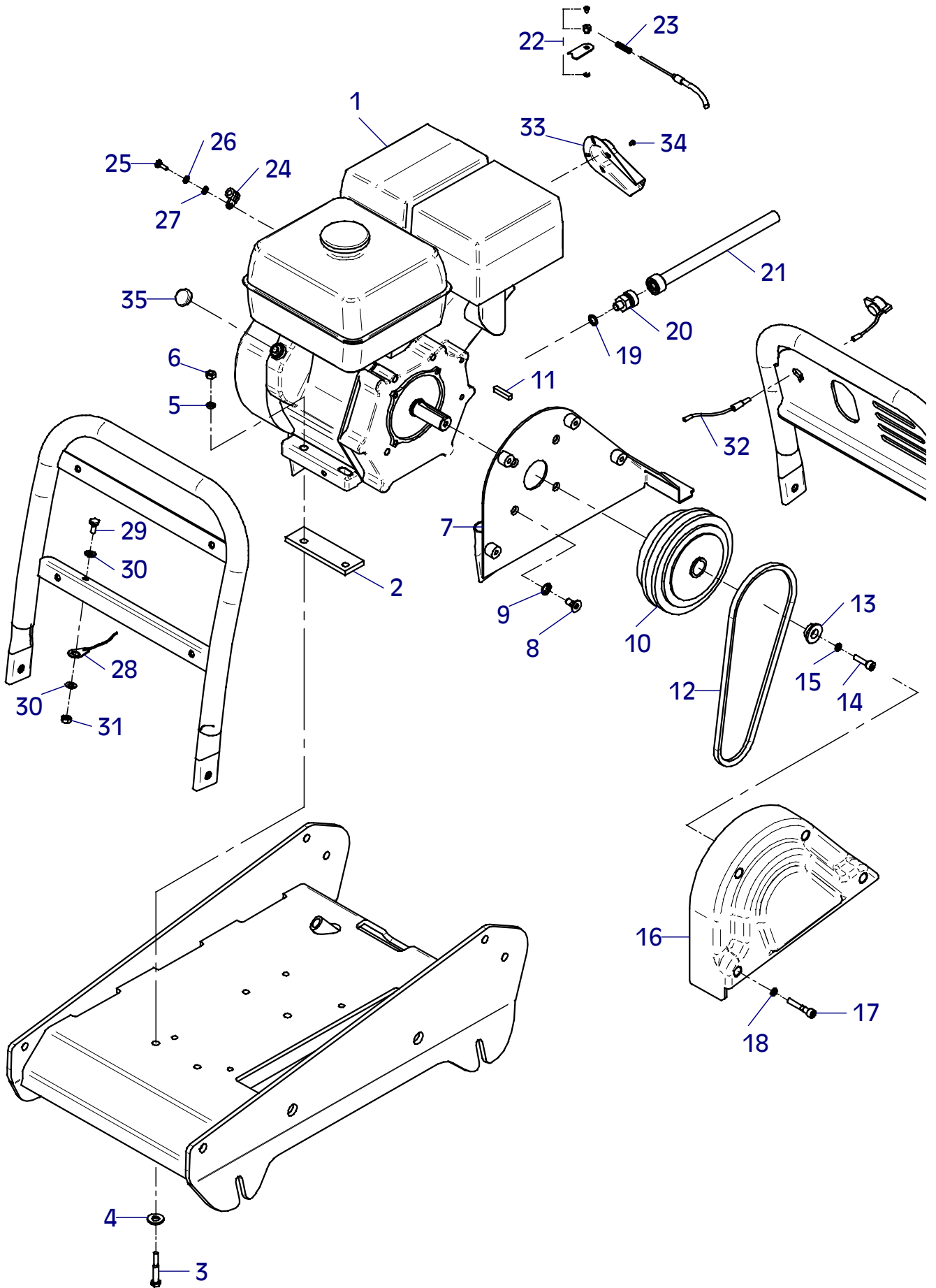

E 3267-0907

Position Ref.No. Repère Posizione Posicion	Menge Quantity Quantité Quantita Cantidad	Teile-Nr. Part-No. No. Référence Nr. d'Ordine No. Referenzia	Hinweis Hints Indications Indicazione Indicaciones	Position Ref. No. Repère Posizione Posicion	Menge Quantity Quantité Quantita Cantidad	Teile-Nr. Part-No. No. Référence Nr. d'Ordine No. Referenzia	Hinweis Hints Indications Indicazione Indicaciones
1	1	21000323					
2	2	20002548					
3	2	20002269					
4	2	21000151					
5	3	21000357					

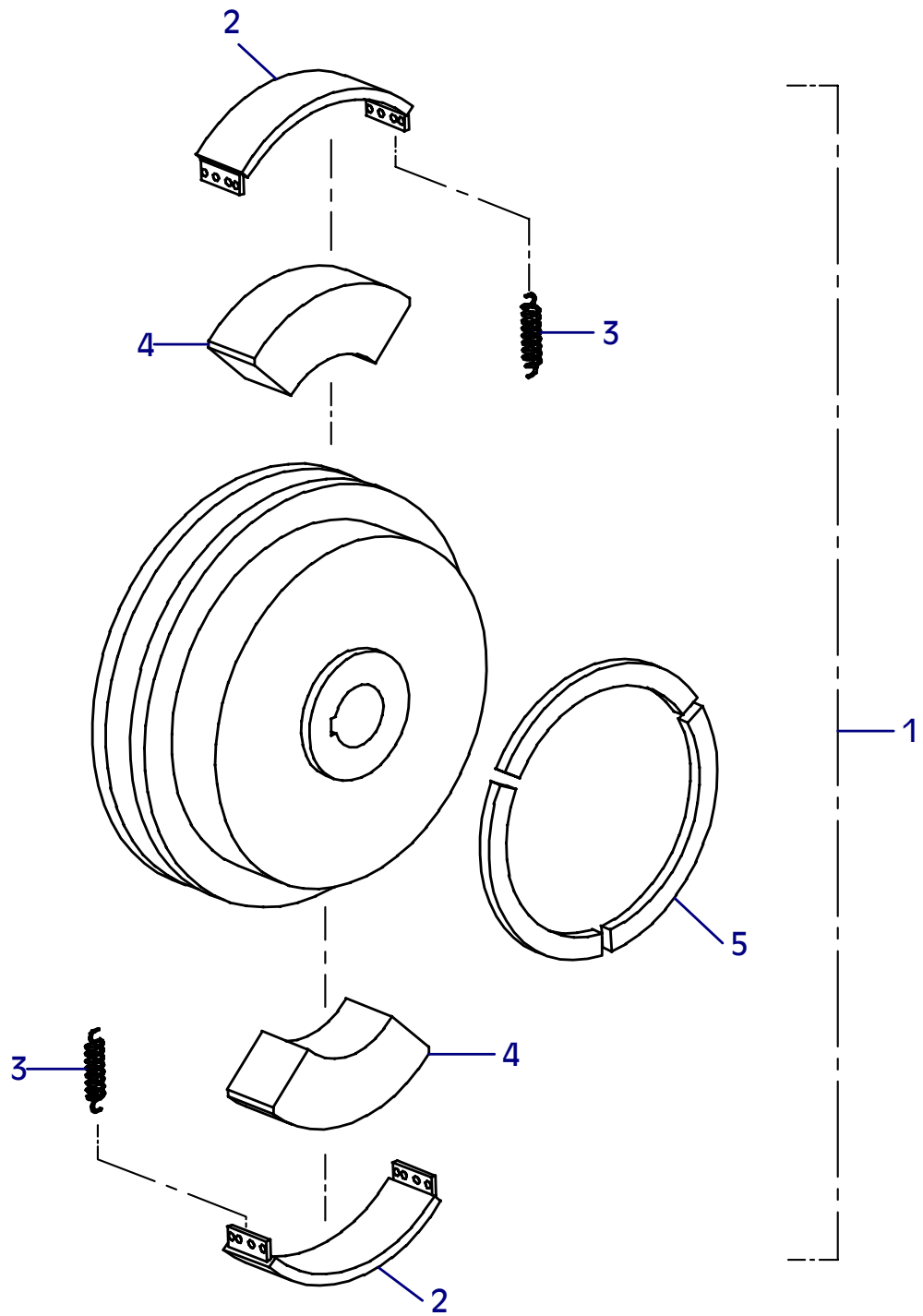

E 3261-0308

Position Ref.No. Repère Posizione Posicion	Menge Quantity Quantité Quantita Cantidad	Teile-Nr. Part-No. No. Référence Nr. d'Ordine No. Referenzia	Hinweis Hints Indications Indicazione Indicaciones	Position Ref. No. Repère Posizione Posicion	Menge Quantity Quantité Quantita Cantidad	Teile-Nr. Part-No. No. Référence Nr. d'Ordine No. Referenzia	Hinweis Hints Indications Indicazione Indicaciones
1	1	11000460		30	1	20013284	
2	2	10016876		31	1	25035027	DIN472-I58x2
3	4	25044046	DIN912-M8x55	32	1	20020119	
4	4	20029011	VSKZ 8	33	1	21000324	
5	2	20026493		34	4	25044006	DIN912-M8x25
6	2	10016877		35	4	20029011	VSKZ 8
7	2	25040033	DIN931-M12x70	36	1	10017394	
8	2	20029004	VSK 12	37	2	10017397	
9	2	25048004	DIN125-A13	38	2	20013271	
10	2	20026546		39	2	25017048	
11	2	20004061		40	2	10017396	
12	2	25038018	DIN933-M12x20	41	2	25044035	DIN912-M12x25
13	2	20029023	SKB 12	42	2	20029013	VSKZ 12
14	1	11000567		43	2	11000056	
15	2	20005019		44	1	11000038	
16	2	25031004	DIN934-M10	45	4	25038008	DIN933-M8x25
17	1	21000253	Hatz	46	4	20029003	VSK 8
17	1	21000349	Honda	47	2	20025593	
18	2	21000258	DIN933-M5x30	48	1	21000261	
19	2	20029006	VSK 5	49	1	20007202	
20	1	25009021					
21	1	11000455					
22	1	25030003	DIN908-M24x1,5				
23	1	25008008	DIN7603-24x32x2				
24	1	25030002	DIN908-M14x1,5				
25	1	21000256					
26	1	11000456					
27	1	20008067					
28	1	20013282					
29	1	11000457					

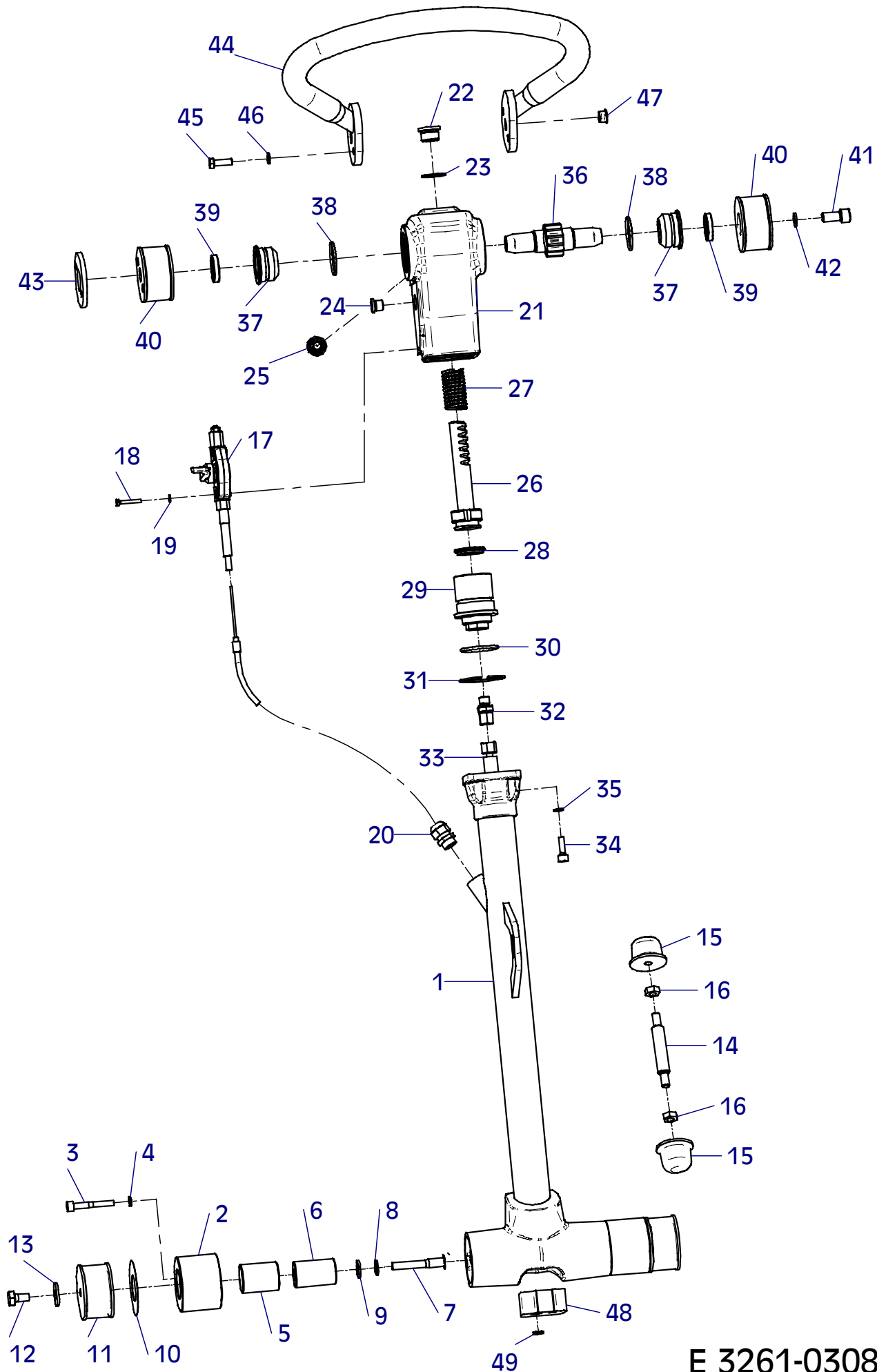

E 3261-0308

E 3266-0208

Position Ref.No. Repère Posizione Posicion	Menge Quantity Quantité Quantita Cantidad	Teile-Nr. Part-No. No. Référence Nr. d'Ordine No. Referenzia	Hinweis Hints Indications Indicazione Indicaciones	Position Ref. No. Repère Posizione Posicion	Menge Quantity Quantité Quantita Cantidad	Teile-Nr. Part-No. No. Référence Nr. d'Ordine No. Referenzia	Hinweis Hints Indications Indicazione Indicaciones
1	2	11000338					
2	4	25038046	DIN933-M16x50-10.9				
3	4	20029002	VSK 16				
4							
5							
6							
7							
8							
9							
10	2	11000615					
11	4	25038046	DIN933-M16x50-10.9				
12	4	20029002	VSK 16				

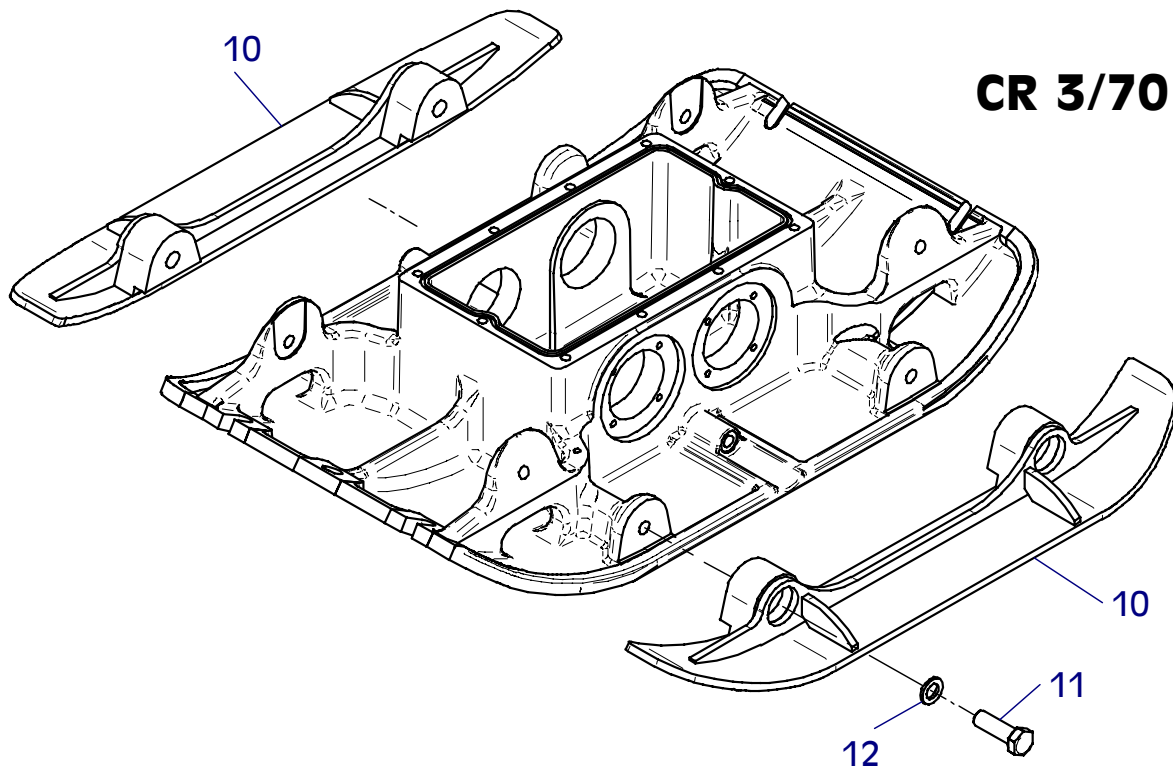
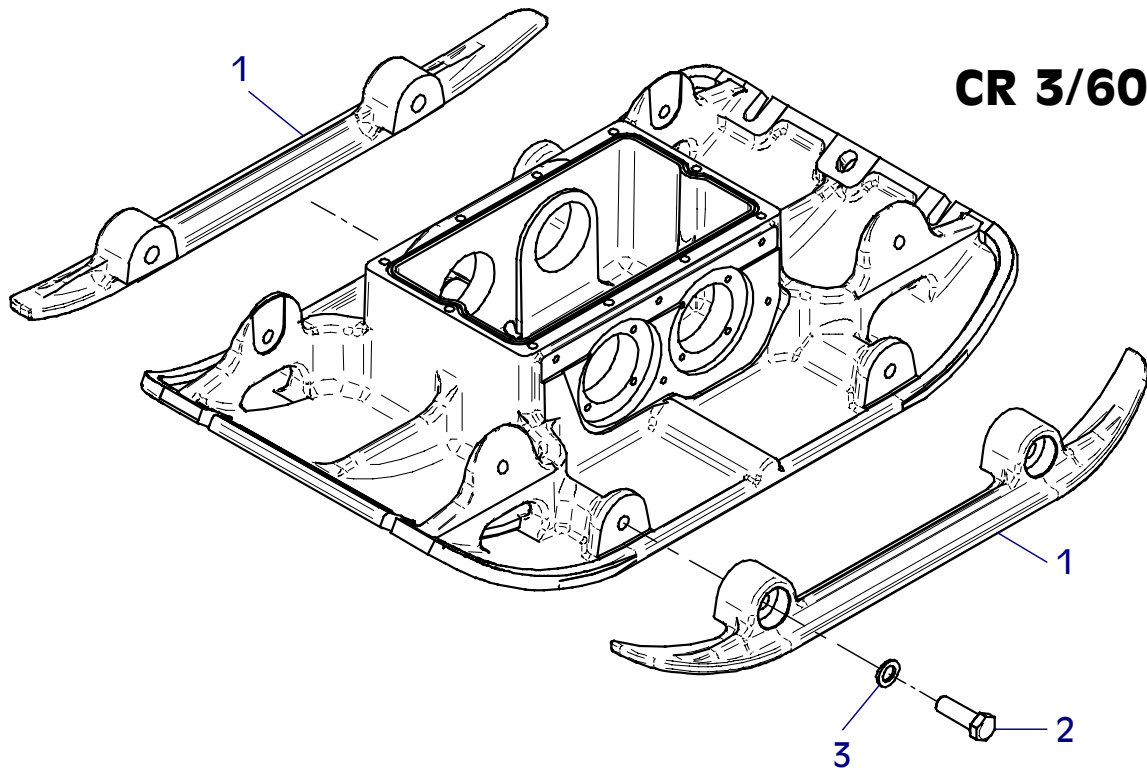

E 3290-1207

Position Ref.No. Repère Posizione Posicion	Menge Quantity Quantité Quantita Cantidad	Teile-Nr. Part-No. No. Référence Nr. d'Ordine No. Referenzia	Hinweis Hints Indications Indicazione Indicaciones	Position Ref. No. Repère Posizione Posicion	Menge Quantity Quantité Quantita Cantidad	Teile-Nr. Part-No. No. Référence Nr. d'Ordine No. Referenzia	Hinweis Hints Indications Indicazione Indicaciones
1	1	11000610					
2	2	11000612					
3	4	25040019	DIN931-M12x55				
4	4	25048004	DIN125-A13				
5	4	20029023	SKB 12				
6	4	25031005	DIN934-M12				
7							
8							
9							
10	1	11000611					
11	2	11000612					
12	4	25040019	DIN931-M12x55				
13	4	25048004	DIN125-A13				
14	4	20029023	SKB 12				
15	4	25031005	DIN934-M12				

CR 3

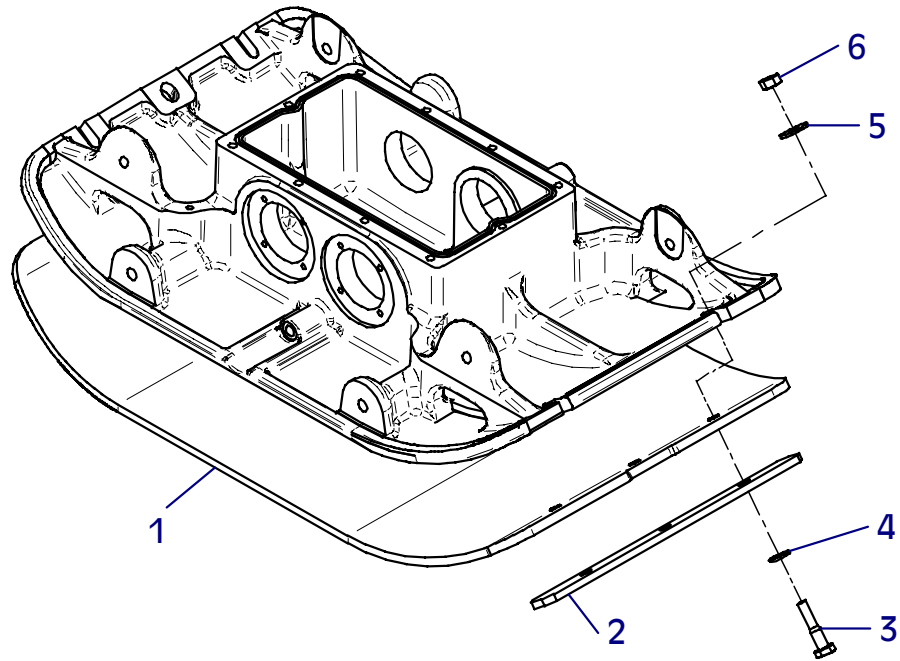

CR 3/60

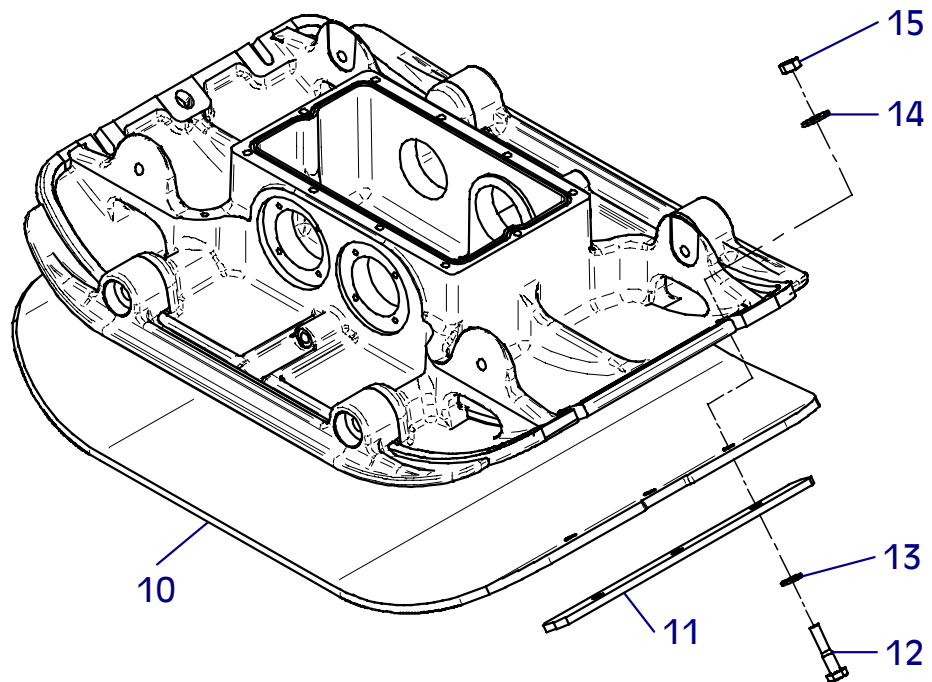

E 3031-1207

Position Ref.No. Repère Posizione Posicion	Menge Quantity Quantité Quantita Cantidad	Teile-Nr. Part-No. No. Référence Nr. d'Ordine No. Referenzia	Hinweis Hints Indications Indicazione Indicaciones	Position Ref. No. Repère Posizione Posicion	Menge Quantity Quantité Quantita Cantidad	Teile-Nr. Part-No. No. Référence Nr. d'Ordine No. Referenzia	Hinweis Hints Indications Indicazione Indicaciones
1	1	10022502	CR3 , CR4				
1	1	10022504	CR3/60 , CR4/65				
2	1	10016239					
3	1	20025508					
4	1	25031004	DIN934-M10				
5	1	25038060	DIN933-M10x50				
6	2	20025007					
7	4	25048006	DIN125-A21				
8	2	25037011					
9	1	10022503					
10	1	25040018	DIN931-M12x50				
11	1	25048004	DIN125-A13 - CR4				
11	1	25049011	CR3				
12	1	20029023	SKB 12				
13	1	25031005	DIN934-M12				

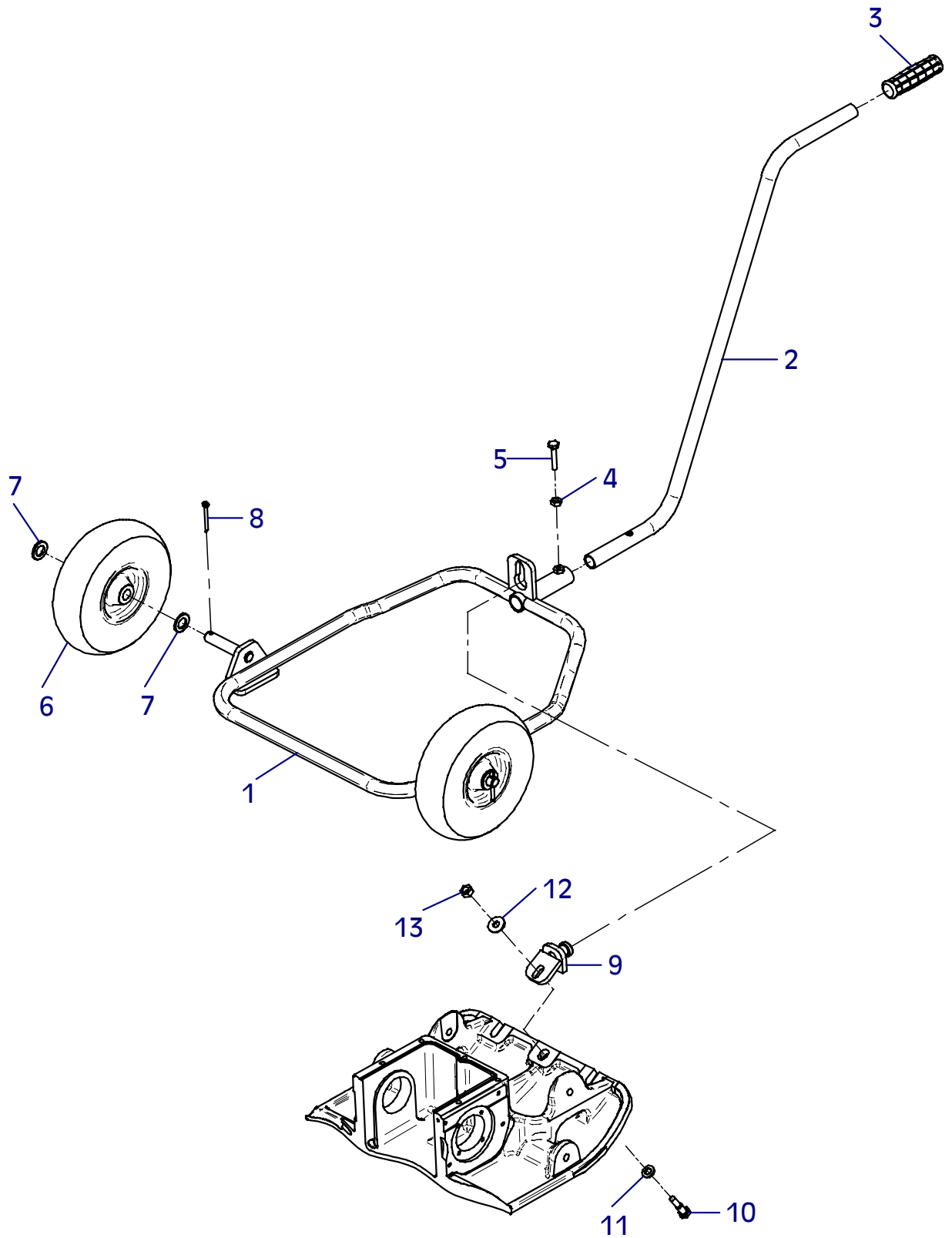

E 3032-1207

Position Ref.No. Repère Posizione Posicion	Menge Quantity Quantité Quantita Cantidad	Teile-Nr. Part-No. No. Référence Nr. d'Ordine No. Referenzia	Hinweis Hints Indications Indicazione Indicaciones	Position Ref. No. Repère Posizione Posicion	Menge Quantity Quantité Quantita Cantidad	Teile-Nr. Part-No. No. Référence Nr. d'Ordine No. Referenzia	Hinweis Hints Indications Indicazione Indicaciones
1	1	10022502	CR3 , CR4				
1	1	10022504	CR3/60 , CR4/65				
2	1	10016239					
3	1	20025508					
4	1	25031004	DIN934-M10				
5	1	25038060	DIN933-M10x50				
6	2	20025007					
7	4	25048006	DIN125-A21				
8	2	25037011					
9	1	10022503					
10	1	25040033	DIN931-M12x70				
11	1	25048004	DIN125-A13 - CR4				
11	1	25049011	CR3				
12	1	20029023	SKB 12				
13	1	25031005	DIN934-M12				

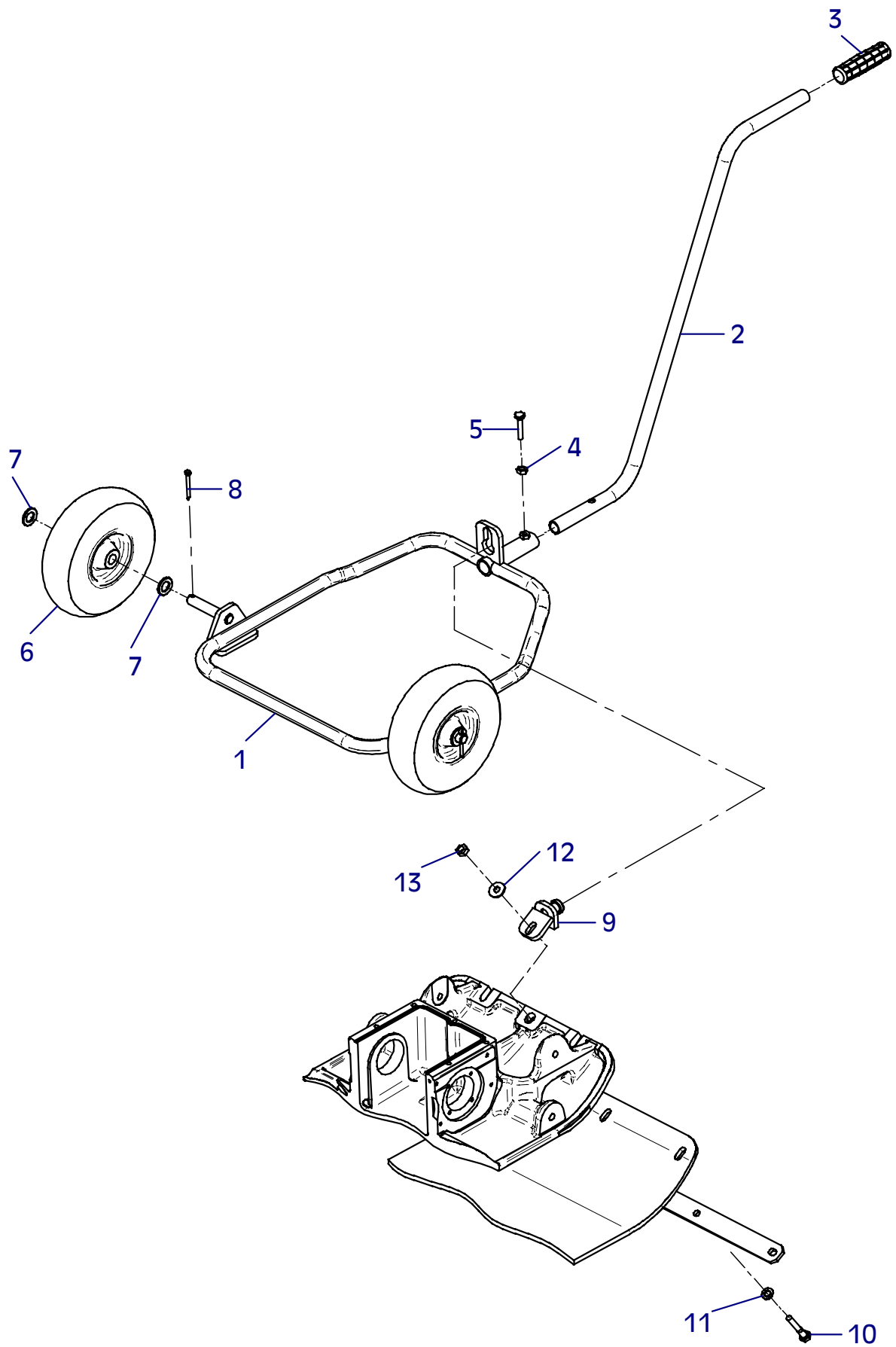

E 3032-1207

**Wenn Sie Fragen und Anregungen haben, oder sonstige Informationen benötigen,
wenden Sie sich bitte an eine der unten genannten Adressen:**

**For questions and further information refer to one of the
following addresses:**

<p>In Deutschland</p> <p>In Germany</p>	<p>WEBER Maschinenteknik GmbH Postfach 2153 57329 Bad Laasphe – Rückershausen</p> <p>Information / information: E-mail: info@webermt.de</p> <p>Ersatzteile / spare parts: E-mail: parts@webermt.de</p>	<p>Telefon / phone:</p> <p>Telefax / fax:</p> <p>Telefax / fax:</p>	<p>+49 (0) 2754 / 3980 Zentrale / switchboard</p> <p>+49 (0) 2754 / 398101 Zentrale / switchboard</p> <p>+49 (0) 2754 / 398102 Ersatzteile / spare parts direct dial</p>
<p>In Holland</p> <p>In Netherlands</p>	<p>WEBER Maschinenteknik B.V. Graafschap Hornelaan 159 6001 AC Weert</p> <p>E-mail: info@webermt.nl</p>	<p>Telefon / phone:</p> <p>Telefax / fax:</p>	<p>+31 (0) 495 / 530215</p> <p>+31 (0) 495 / 541839</p>
<p>In Frankreich</p> <p>In France</p>	<p>WEBER Technologie S.A.R.L. 26, rue d'Arsonval 69680 Chassieu</p> <p>E-mail: france@webermt.com</p>	<p>Telefon / phone:</p> <p>Telefax / fax:</p>	<p>+33 (0) 472 / 791020</p> <p>+33 (0) 472 / 791021</p>
<p>In Polen</p> <p>In Poland</p>	<p>WEBER Maschinenteknik SP.ZO.O. ul. Grodziska 7 05-830 Stara Wies / Nadarzyn</p> <p>E-mail: info@webermt.com.pl</p>	<p>Telefon / phone:</p> <p>Telefax / fax:</p>	<p>+48 (0) 22 / 7397080 +48 (0) 22 / 7397081</p> <p>+48 (0) 22 / 7397082</p>
<p>In USA, Kanada</p> <p>In USA, Canada</p>	<p>WEBER Machine (USA), Inc. 40 Johnson Ave 112 Bangor, ME 04401 USA</p> <p>E-mail: usa@webermt.com</p>	<p>Telefon / phone:</p> <p>Telefax / fax:</p>	<p>+1 (0) 207 / 9474990</p> <p>+1 (0) 207 / 9475452</p>
<p>In Südamerika</p> <p>In South America</p>	<p>WEBER Maschinenteknik do Brasil Ltda. Rua Sete de Setembro, 275 93332-470 Novo Hamburgo, RS Brasil</p> <p>E-mail: webermt@webermt.com.br</p>	<p>Telefon / phone:</p> <p>Telefax / fax:</p>	<p>+55 (0) 51 / 5873044</p> <p>+55 (0) 51 / 5872271</p>

<http://www.webermt.com>

