



**ERSATZTEILLISTE**

**SPARE PARTS LIST**

**LISTE DES PIECES  
DE RECHANGE**

**LISTINO RICAMBI**

**LISTA DE RECAMBIOS**

**WYKAZ CZESCI  
ZAMIENNYCH**



**CR 3**  
**CR 3/60**

**011610-011615**



Weber Maschinenteknik GmbH  
Postfach 2153, 57329 Bad Laasphe-Rückershausen  
Telefon 02754 / 398-0  
Telefax (02754) 398-101 (Zentrale) u. 398-102 (Ersatzteile)

## EG - KONFORMITÄTSERKLÄRUNG

EC DECLARATION OF CONFORMITY / DECLARATION DE CONFORMITE CE  
DICHIARAZIONE CE DI CONFORMITA / DECLARACION CE DE CONFORMIDAD  
EG-VERKLARING VAN OVEREENSTEMMING / EF-OVERENSSTEMMELSESERKAERING  
DECLARACAO CE DE CONFORMIDADE / EG-FÖRSÄKRAN OM ÖVERENSSTÄMMELSE  
DEKLARACJA ZGODNOŚCI

### im Sinne der EG-Maschinenrichtlinie 98/37/EG und der EG Richtlinie 2000/14/EG - Geräuschemissionen

- I **Art / Category / Catégorie / Categoria Tipo / Kategori /**  
Soort / Categoria / kategori / Typ
- II **Hersteller (Typ) / Make (Type) / Marque (Type) / Marca (Tipo) /**  
Marca (Codice) / Producent (Type) / Merk (Type) / Marca (Tipo) /  
Tillverkare (Typ) / Producent
- III **Nennleistung / Nominal-performance / La puissance nominale / Prestazione nominale /**  
Potencia nominal / Nominaal vermogen / Nominel ydelse / Potência nominal / Nominell  
effect / Moc
- IV **gemessener Schalleistungspegel / measured sound power level / niveau de**  
puissance acoustique mesure / livello di potenza sonora rilevato / nivel de potencia  
acústica medido / gemeten geluidsvermogensniveau / målt lydeffektniveau / Nivel de  
potência sonora midido / uppmätt ljudeffektnivå / Mierzony poziom dźwięku
- V **garantierter Schalleistungspegel / guaranteed sound power level / niveau de**  
puissance acoustique garanti / livello di potenza sonora garantito / nivel de potencia  
acústica garantizado / gwarantowany poziom mocy / gwarantowany poziom dźwięku /  
Nivel sonoro garantido / gwarantowany poziom dźwięku / Natężenie hałasu
- VI **beteiligte Zertifizierungsstelle / notified body involved / de l'organisme notifié /**  
dell'organismo notificato che l'ha effettuata / dirección del organismo notificado que haya  
intervenido / betrokken aangemelde instantie / pågældende bemyndigede organ /  
organismo notificado involucrado / berörda anmälda organets namn / Jednostka  
certyfikująca
- VII **Konformitäts-Bewertungsverfahren / Conformity assessment procedure followed /**  
la procédure appliquée pour l'évaluation de la conformité et / procedura di valutazione  
della conformità / procedimiento de evaluación de la conformidad / gevolgde  
overeenstemmingsbeoordelingsprocedure / den fulgte  
overensstemmelssesvurderingsprocedure / procedimento de avaliacao de conformidade  
/ Vilket förfarande för bedömning av överensstämmelse / Przebieg kontroli

Vibrationsplatte  
CR 3



P = 3,4 / 6,3 kW

LWA = 106 dB (A)

LWA = 108 dB (A)

RWTÜV  
Postfach 103161  
D-45032 Essen

interne Fertigungskontrolle  
nach Anhang VI  
EG Richtlinie 2000/14/EG

**ist in Übereinstimmung mit folgenden Richtlinien hergestellt worden / has been produced in accordance with following standards / est produit conforme aux dispositions des directives européennes ci-apres / ha sido fabricado en conformidad con las siguientes normas / é stato fabbricato in conformità alle sequenti norme / er blevet fremstillet i overensstemmelse med følgende retningslinier / in overeenstemming met de volgende voorschriften gefabriceerd is / é fabricado conforme as seguintes normas / har tillverkats i överensstämmelse med följande riktlinjer / Zgodność z obowiązującymi przepisami**

**98/37/EG** Maschinenrichtlinie des europäischen Parlamentes und des Rates vom 22. Juni 1998  
**2000/14/EG** EG-Richtlinie Geräuschemissionen vom 8. Mai 2000  
**EN 500 Teil 1** Bewegliche Straßenbaumaschinen – Sicherheit  
Gemeinsame Anforderungen  
**EN 500 Teil 4** Bewegliche Straßenbaumaschinen – Sicherheit  
Besondere Anforderungen an Verdichtungsmaschinen

**Bescheinigung bitte sorgfältig aufbewahren / File certificate carefully / Conserver certificat soigneusement / Conservar certificado cuidadosamente / Pregasi conservare accuratamente certificato / Beviset bedes opbevares omhyggeligt / Verklaring a.u.b. zorgvuldig beware / Conservar o certificado com cuidado / Beviset skall om sorgsfullt bevaras // Deklarację zgodności proszę zachować**

Bad Laasphe – Rückershausen, den 02.01.2004

  
W. Weber, Geschäftsführer

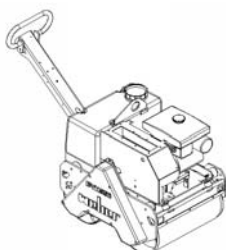

**WEBER Maschinentechnik GmbH**

Im Boden 5-8, 10 – D-57334 Bad Laasphe  
Postfach 2153 – D-57329 Bad Laasphe  
Telefon: 02754/398-0 – Fax 02754/398-101  
E-mail: [Verkauf@webermt.de](mailto:Verkauf@webermt.de)  
Internet: <http://www.webermt.de>



BITTE, NOTIEREN SIE SERIENNUMMER UND MOTORNUMMER IHRER MASCHINE:

PLEASE WRITE DOWN SERIALNUMBERS OF MACHINE AND ENGINE:

NOTEZ SVP LE NUMERO DE SERIE ET LE NUMERO DU MOTEUR DE VOTRE MACHINE:

SI PREGA DI ANNOTARE SEMPRE I NUMERI DI SERIE SIA DELLA VS. MACCHINA CHE DEL MOTORE:

MAQUINA: ROGAMOS ANOTEN EL NUMERO DE SERIE Y NUMERO DE MOTOR DE SU MAQUINA:

MASCHINE  
MACHINE  
MACCHINA  
MAQUINA

# # #
-------------

MOTOR  
ENGINE  
MOTEUR  
MOTORE

# # #
-------------

ZUR VERMEIDUNG VON FEHLLIEFERUNGEN UND VERZÖGERUNGEN SIND BEI DER BESTELLUNG VON ERSATZTEILEN FOLGENDE ANGABEN UNBEDINGT ERFORDERLICH:

- MASCHINENTYP
- SERIENNUMMER DER MASCHINE
- SERIENNUMMER DES MOTORS (BEI MOTORTEILEN)
- TEILENUMMER
- BESTELLMENGE

TO AVOID ERRORS IN DELIVERY PLEASE STATE THESE PARTICULARS WHEN ORDERING:

- TYPE OF MACHINE
- SERIAL NO. OF MACHINE
- SERIAL NO. OF ENGINE (ON ENGINE PARTS)
- PART-NO.
- QUANTITY REQUIRED

AFIN D'EVITER DES ERREURS DE COMMANDE ET DES RETARDS DE LIVRAISON IL EST NECESSAIRE D'INDIQUER LES CARACTERISTIQUES SUIVANTES:

- TYPE DE MACHINE
- LE NUMERO DE SERIE DE LA MACHINE
- LE NUMERO DE SERIE DU MOTEUR
- LE NUMERO D'IDENTITE DE LA PIECE
- LA QUANTITE SOUHAITEE

ONDE EVITARE DISGUIDI E RITARDI NELLE CONSEGNE DIE RICAMBI SI PREGA DI INDICARE SEMPRE:

- TIPO DELLA MACCHINA
- NUMERO DI SERIE DELLA MACCHINA
- NUMERO DI SERIE DEL MOTORE (SE SI RICHIEDONO PEZZI DEL MOTORE)
- NUMERO D'ORDINE DIE SINGOLI RICAMBI
- QUANTITA

A FI DE EVITAR ERRORES DE ENTREGA, ROGAMOS INDIQUEN LOS SIGUIENTES DATOS CUANDO PASE PEDIDOS DE RECAMBIO:

- MODELO DE MAQUINA
- NO. DE SERIE DE LA MAQUINA
- NO. DE SERIE DEL MOTOR (EN PIEZAS PARA MOTOR)
- REFERENCIA DEL RECAMBIO
- CANTIDAD PEDIDA

## E 3165-0704

Position Ref.No. Repère Posizione Posicion	Menge Quantity Quantité Quantita Cantidad	Teile-Nr. Part-No. No. Référence Nr. d'Ordine No. Referenzia	Hinweis Hints Indications Indicazione Indicaciones	Position Ref. No. Repère Posizione Posicion	Menge Quantity Quantité Quantita Cantidad	Teile-Nr. Part-No. No. Référence Nr. d'Ordine No. Referenzia	Hinweis Hints Indications Indicazione Indicaciones
1	1	10016003					
2	1	25030002	DIN908-M14x1,5				
3	4	20004011					
4	4	20029023	SKB 12				
5	4	25031005	DIN934-M12				
6	1	10016342					
7	1	10016343					
8	1	10001413					
9	6	25045047	DIN912-M12x90				
10	2	25045048	DIN912-M12x150				
11	8	20029026					
12	4	25038018	DIN933-M12x20				
13	4	20029004	VSK 12				

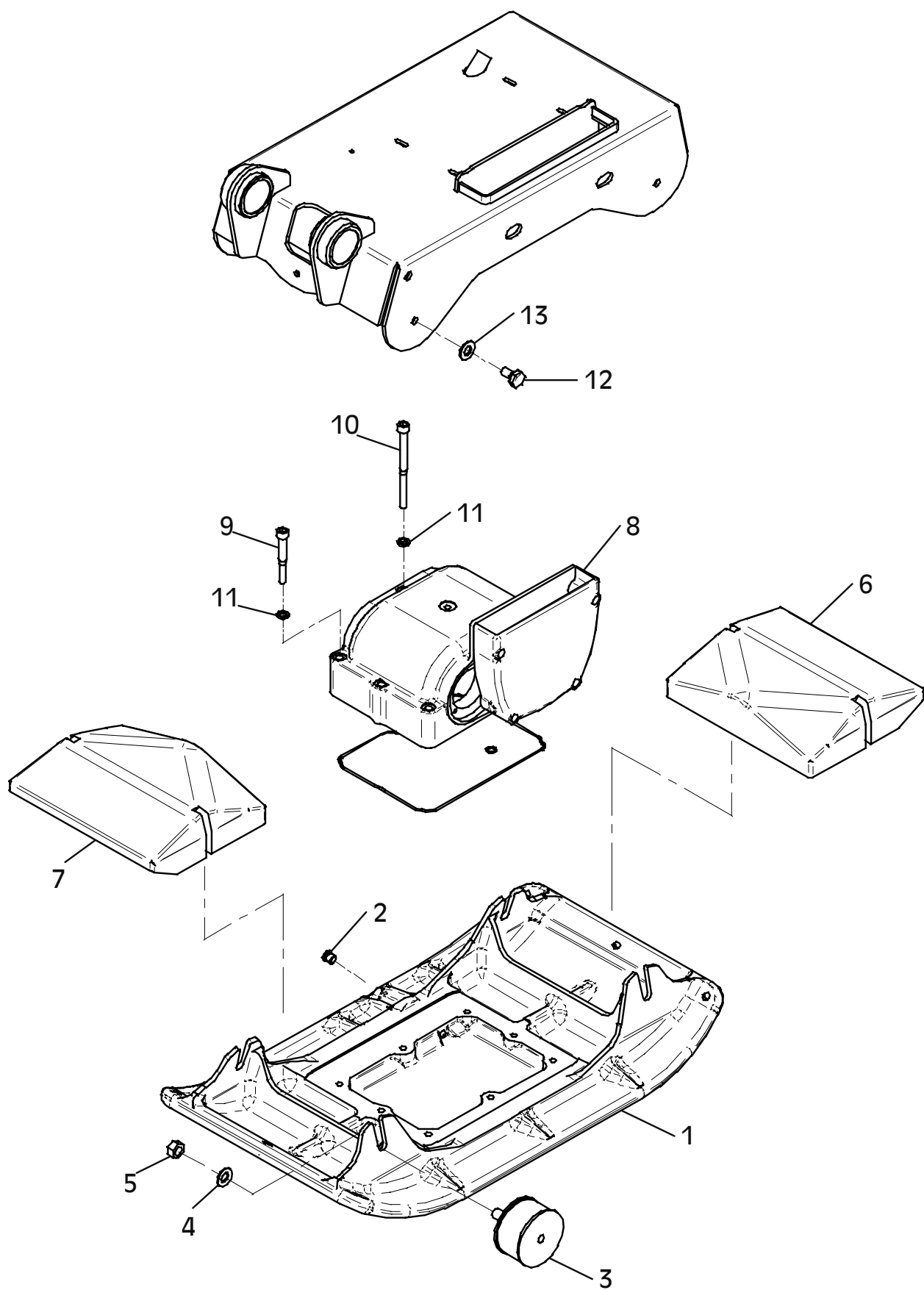

E 3165-0704

## E 3166-0704

Position Ref.No. Repère Posizione Posicion	Menge Quantity Quantité Quantita Cantidad	Teile-Nr. Part-No. No. Référence Nr. d'Ordine No. Referenzia	Hinweis Hints Indications Indicazione Indicaciones	Position Ref. No. Repère Posizione Posicion	Menge Quantity Quantité Quantita Cantidad	Teile-Nr. Part-No. No. Référence Nr. d'Ordine No. Referenzia	Hinweis Hints Indications Indicazione Indicaciones
1	1	10016004					
2	1	25030002	DIN908-M14x1,5				
3	4	20004011					
4	4	20029023	SKB 12				
5	4	25031005	DIN934-M12				
6	1	10016342					
7	1	10016343					
8	1	10001413					
9	6	25045047	DIN912-M12x90				
10	2	25045048	DIN912-M12x150				
11	8	20029026					
12	4	25038018	DIN933-M12x20				
13	4	20029004	VSK 12				

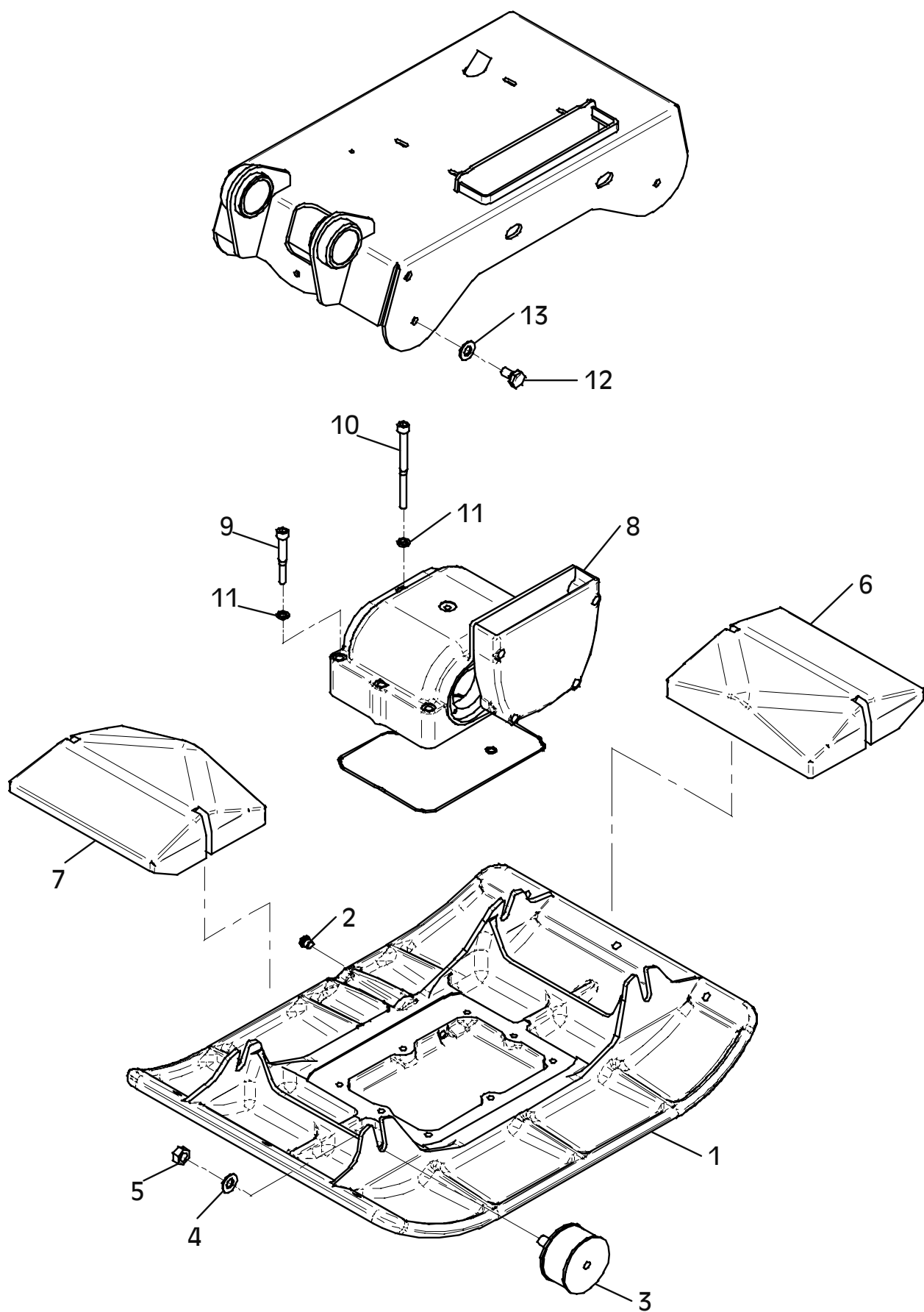

E 3166-0704

## E 3167-0704

Position Ref.No. Repère Posizione Posicion	Menge Quantity Quantité Quantità Cantidad	Teile-Nr. Part-No. No. Référence Nr. d'Ordine No. Referenzia	Hinweis Hints Indications Indicazione Indicaciones	Position Ref. No. Repère Posizione Posicion	Menge Quantity Quantité Quantità Cantidad	Teile-Nr. Part-No. No. Référence Nr. d'Ordine No. Referenzia	Hinweis Hints Indications Indicazione Indicaciones
1	1	10016363		31	2	25045028	DIN912-M10x35
2	1	25039005	DIN933-M12x20	32	2	25025245	
3	1	25008011	DIN7603-12x18x1,5	33	1	10016064	
4	1	20013302		34	1	20013269	
5	1	20013103		35	4	25044100	DIN912-M8x16
6	1	10016364		36	4	20029011	VSKZ 8
7	4	25044008	DIN912-M8x40	37	1	25030016	DIN910-M10x1
8	4	20029011	VSKZ 8	38	1	25008012	DIN7603-10x16x1
9	2	10016060		39	1	20020119	
10	2	20013269		40	1	10016067	
11	8	25044100	DIN912-M8x16	41	2	25001151	
12	8	20029011	VSKZ 8	42	1	10016063	
13	0	20025528		43	2	25001022	
14	0	20025029		44	2	10016074	
15	0	20025378		45	1	10016069	
16	1	10016061		46	1	10016109	
17	1	25017047		47	2	25045028	DIN912-M10x35
18	1	20013269		48	2	25025245	
19	4	25046015	DIN7984-M8x16	49	1	10016065	
20	4	20029011	VSKZ 8	50	1	10008320	
21	1	10016070		51	1	25027004	DIN914-M8x16
22	1	10016071		52	1	25001513	
23	1	20029001	VSK 10	53	1	25034002	DIN471-A12
24	1	10007370		54	1	25035026	DIN472-I28x1,2
25	1	10016068		55	1	10016066	
26	2	25001151		56	1	20013270	
27	1	10016062					
28	1	25015046					
29	1	10016069					
30	1	10016109					

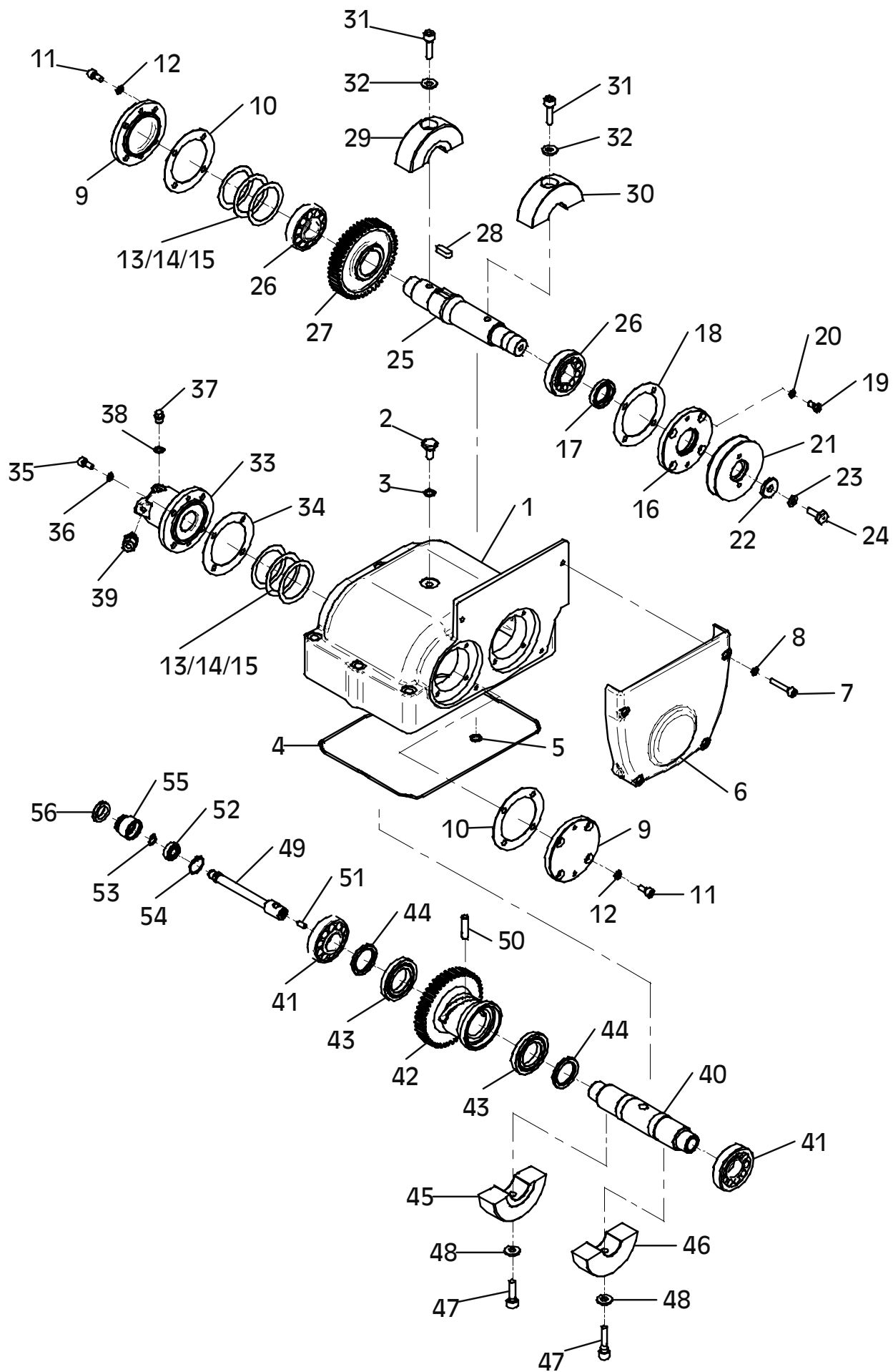

E 3167-0704

## E 3168-0704

Position Ref.No. Repère Posizione Posicion	Menge Quantity Quantité Quantita Cantidad	Teile-Nr. Part-No. No. Référence Nr. d'Ordine No. Referenzia	Hinweis Hints Indications Indicazione Indicaciones	Position Ref. No. Repère Posizione Posicion	Menge Quantity Quantité Quantita Cantidad	Teile-Nr. Part-No. No. Référence Nr. d'Ordine No. Referenzia	Hinweis Hints Indications Indicazione Indicaciones
1	1	10022227		31	1	20025765	
2	2	20004036		32	1	25008017	DIN 7603-22x27x1,5
3	4	20033002		33	1	20007007	
4	1	20005004		34	2	25031002	DIN934-M6
5	2	25049016	DIN440-R9	35	1	40031335	
6	1	20029003	VSK 8	36	1	40031336	
7	1	25031003	DIN934-M8	37	1	40031334	
8	1	25038003	DIN933-M6x20	38	1	40031344	
9	1	25048001	DIN125-B6,4	39	1	10022228	
10	1	20007007		40	4	25038020	DIN933-M12x30
11	1	20029007	VSK 6	41	4	20029004	VSK 12
12	1	25031002	DIN934-M6	42	1	20026465	
13	1	25009021		43	2	25025191	DIN80705-M20x1,5
14	1	20025590		44	2	20025019	
15	1	20025271					
16	1	20001227					
17	4	25033012	DIN603-M8x25				
18	4	20029024					
19	4	25031003	DIN934-M8				
20	1	10022229					
21	4	25038013	DIN933-M10x20				
22	4	20029001	VSK 10				
23	1	20002081					
24	1	25002092					
25	1	25044009	DIN912-M8x45				
26	1	20029011	VSKZ 8				
27	1	25049016	DIN440-R9				
28	1	10016028					
29	4	25044060	DIN912-M8x80				
30	4	20029011	VSKZ 8				

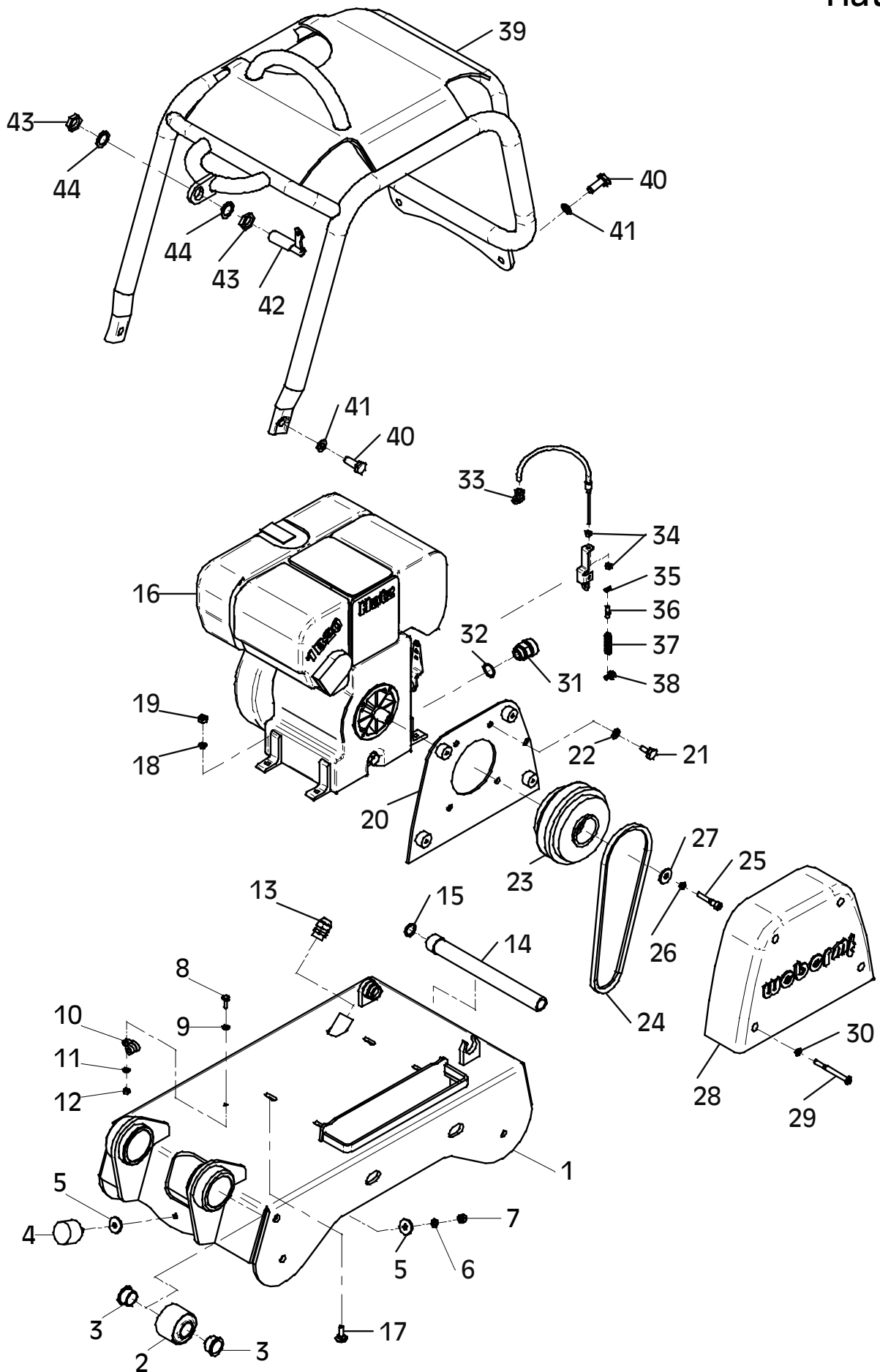

## E 3169-0704

Position Ref.No. Repère Posizione Posicion	Menge Quantity Quantité Cantidad	Teile-Nr. Part-No. No. Référence Nr. d'Ordine No. Referenzia	Hinweis Hints Indications Indicazione Indicaciones	Position Ref. No. Repère Posizione Posicion	Menge Quantity Quantité Cantidad	Teile-Nr. Part-No. No. Référence Nr. d'Ordine No. Referenzia	Hinweis Hints Indications Indicazione Indicaciones
1	1	20002081					
2	2	20002523					
3	4	20002232					

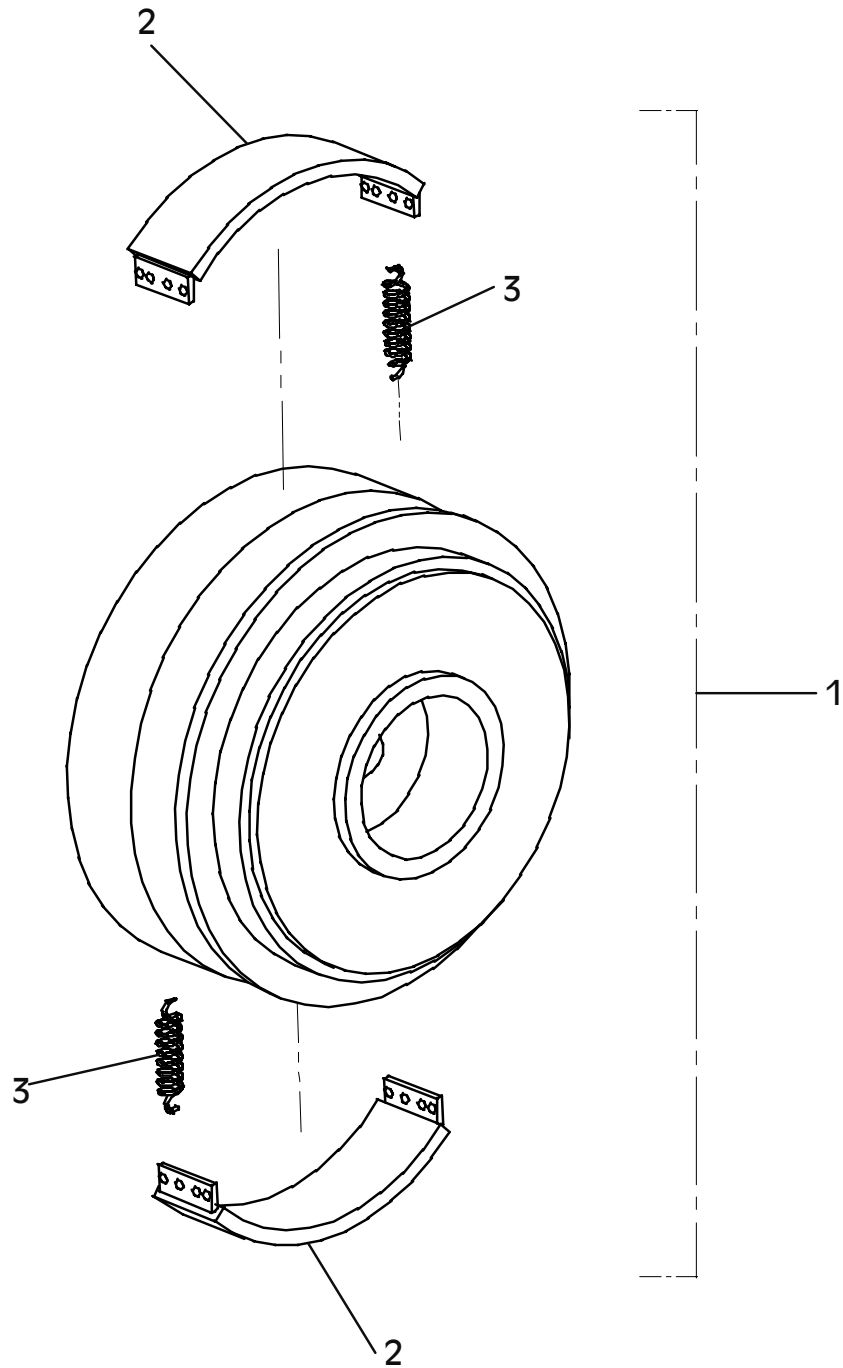

## E 3170-0704

Position Ref.No. Repère Posizione Posicion	Menge Quantity Quantité Quantita Cantidad	Teile-Nr. Part-No. No. Référence Nr. d'Ordine No. Referenzia	Hinweis Hints Indications Indicazione Indicaciones	Position Ref. No. Repère Posizione Posicion	Menge Quantity Quantité Quantita Cantidad	Teile-Nr. Part-No. No. Référence Nr. d'Ordine No. Referenzia	Hinweis Hints Indications Indicazione Indicaciones
1	1	10022246		31	1	20029011	VSKZ 8
2	2	20004036		32	1	20026475	
3	4	20033002		33	1	10016028	
4	1	20005004		34	4	25044060	DIN912-M8x80
5	2	25049016	DIN440-R9	35	4	20029011	VSKZ 8
6	1	20029003	VSK 8	36	1	20025702	
7	1	25031003	DIN934-M8	37	1	25008006	DIN7603-14x20x2
8	1	25038003	DIN933-M6x20	38	2	25031002	DIN934-M6
9	1	25048001	DIN125-B6,4	39	1	10022247	
10	1	20007007		40	4	25038020	DIN933-M12x30
11	1	20029007	VSK 6	41	4	20029004	VSK 12
12	1	25031002	DIN934-M6	42	1	20026465	
13	1	25009021		43	2	25025191	DIN80705-M20x1,5
14	1	20025704		44	2	20025019	
15	1	20025434					
16	1	20001229					
17	1	30047162					
18	2	25033025	DIN603-M10x30				
19	2	20029025					
20	2	25031004	DIN934-M10				
21	4	25033018	DIN603-M10x55				
22	4	25048010	DIN1440-11x25x3				
23	4	20029025					
24	4	25031004	DIN934-M10				
25	1	10022248					
26	4	25038006	DIN933-M8x16				
27	4	20029003	VSK 8				
28	1	20002084					
29	1	25002056					
30	1	25044005	DIN912-M8x20				

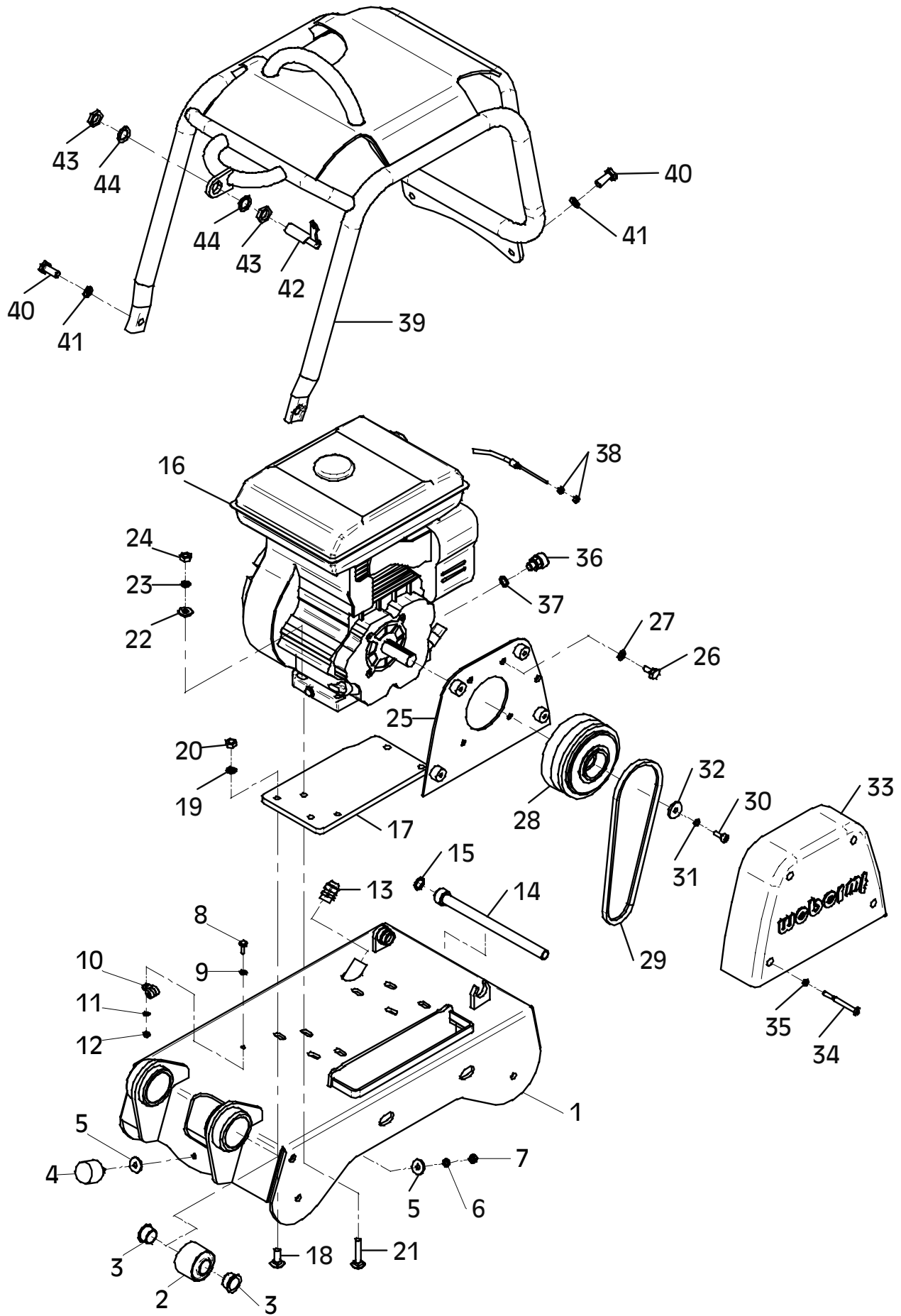

## E 3171-0704

Position Ref.No. Repère Posizione Posicion	Menge Quantity Quantité Quantità Cantidad	Teile-Nr. Part-No. No. Référence Nr. d'Ordine No. Referenzia	Hinweis Hints Indications Indicazione Indicaciones	Position Ref. No. Repère Posizione Posicion	Menge Quantity Quantité Quantità Cantidad	Teile-Nr. Part-No. No. Référence Nr. d'Ordine No. Referenzia	Hinweis Hints Indications Indicazione Indicaciones
1	1	10022246		31	1	10016028	
2	2	20004036		32	4	25044060	DIN912-M8x80
3	4	20033002		33	4	20029011	VSKZ 8
4	1	20005004		34	1	20026204	
5	2	25049016	DIN440-R9	35	1	25008011	DIN7603-12x18x1,5
6	1	20029003	VSK 8	36	1	20026383	
7	1	25031003	DIN934-M8	37	1	40001338	
8	1	25038003	DIN933-M6x20	38	1	20007007	
9	1	25048001	DIN125-B6,4	39	1	25038002	DIN933-M6x16
10	1	20007007		40	1	20029007	VSK 6
11	1	20029007	VSK 6	41	1	25048001	DIN125-B6,4
12	1	25031002	DIN934-M6	42	1	10022249	
13	1	25009021		43	4	25038020	DIN933-M12x30
14	1	20025704		44	4	20029004	VSK 12
15	1	20025434		45	1	20026465	
16	1	20001230		46	2	25025191	DIN80705-M20x1,5
17	2	10016212		47	2	20025019	
18	4	25033013	DIN603-M10x50				
19	4	25048010	DIN1440-11x25x3				
20	4	20029025					
21	4	25031004	DIN934-M10				
22	1	10022501					
23	4	25038007	DIN933-M8x20				
24	4	20029003	VSK 8				
25	1	20002084					
26	1	10016954					
27	1	25002057					
28	1	25044007	DIN912-M8x30				
29	1	20029011	VSKZ 8				
30	1	20026475					

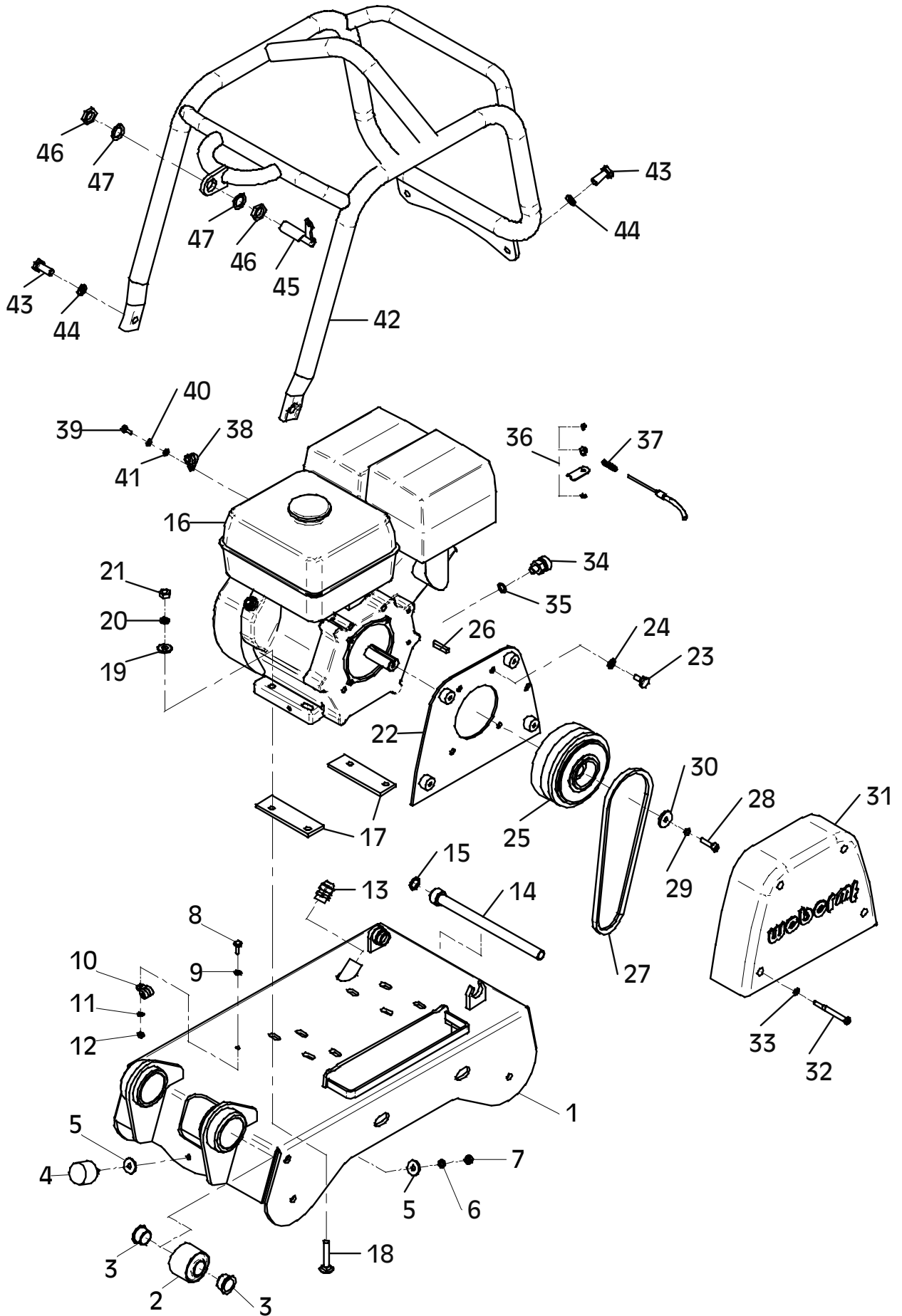

## E 3172-0704

Position Ref.No. Repère Posizione Posicion	Menge Quantity Quantité Quantita Cantidad	Teile-Nr. Part-No. No. Référence Nr. d'Ordine No. Referenzia	Hinweis Hints Indications Indicazione Indicaciones	Position Ref. No. Repère Posizione Posicion	Menge Quantity Quantité Quantita Cantidad	Teile-Nr. Part-No. No. Référence Nr. d'Ordine No. Referenzia	Hinweis Hints Indications Indicazione Indicaciones
1	1	20002084					
2	2	20002548					
3	2	20002269					

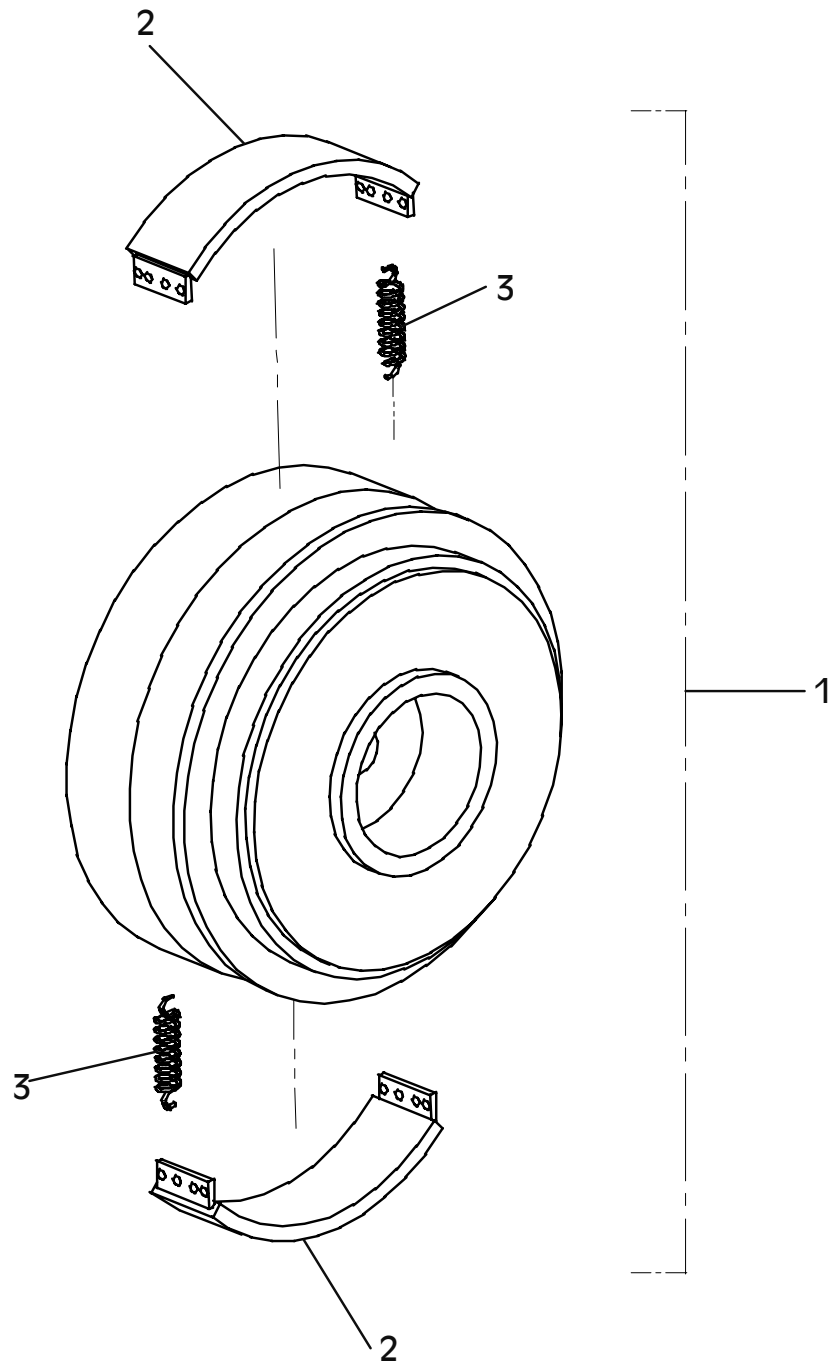

E 3172-0704

## E 3173-0704

Position Ref.No. Repère Posizione Posicion	Menge Quantity Quantité Quantita Cantidad	Teile-Nr. Part-No. No. Référence Nr. d'Ordine No. Referenzia	Hinweis Hints Indications Indicazione Indicaciones	Position Ref. No. Repère Posizione Posicion	Menge Quantity Quantité Quantita Cantidad	Teile-Nr. Part-No. No. Référence Nr. d'Ordine No. Referenzia	Hinweis Hints Indications Indicazione Indicaciones
1	1	10022230		31	2	20026468	
2	2	10016099		32	1	25030002	DIN908-M14x1,5
3	2	25044066	DIN912-M12x90	33	1	20018134	
4	2	20029013	VSKZ 12	34	1	10016100	<b>Hatz / Honda</b>
5	2	25048012	DIN9021-13x40x3	34	1	10016358	<b>Robin</b>
6	1	10016017		35	2	25040067	DIN931-M6x30
7	1	20007202		36	2	20029007	VSK 6
8	1	25009021		37	1	20018021	
9	1	20016364		38	1	20006410	
10	1	20020119					
11	1	10016798					
12	1	25035027	DIN472-I58x2				
13	4	25044007	DIN912-M8x30				
14	4	20029011	VSKZ 8				
15	1	20013274					
16	2	20013273					
17	1	10016102					
18	1	20013275					
19	1	10016022					
20	1	20008067					
21	1	10016797					
22	1	25008008	DIN7603-24x32x2				
23	1	25030003	DIN908-M24x1,5				
24	1	10016776					
25	2	20013271					
26	2	10016101					
27	2	20013272					
28	2	10022521					
29	2	25038020	DIN933-M12x30				
30	2	20029023	SKB 12				

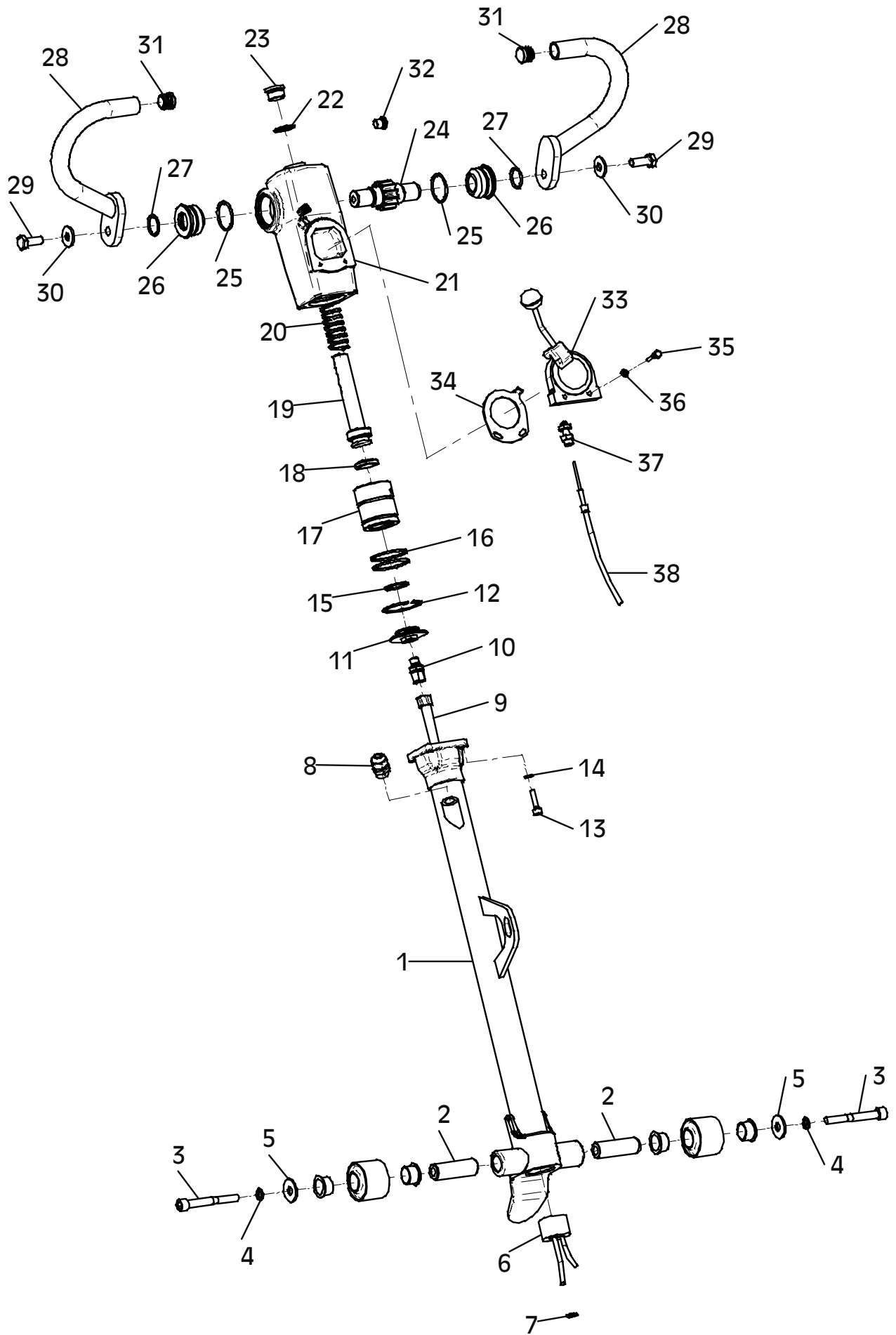

E 3173-0704

## E 3174-0704

Position Ref.No. Repère Posizione Posicion	Menge Quantity Quantité Quantita Cantidad	Teile-Nr. Part-No. No. Référence Nr. d'Ordine No. Referenzia	Hinweis Hints Indications Indicazione Indicaciones	Position Ref. No. Repère Posizione Posicion	Menge Quantity Quantité Quantita Cantidad	Teile-Nr. Part-No. No. Référence Nr. d'Ordine No. Referenzia	Hinweis Hints Indications Indicazione Indicaciones
1	1	10016113					
2	2	10016114					
3	6	25040019	DIN931-M12x55				
4	6	20029004	VSK 12				
5	6	25031005	DIN934-M12				
6							
7							
8							
9							
10	1	10016115					
11	2	10016116					
12	6	25040019	DIN931-M12x55				
13	6	20029004	VSK 12				
14	6	25031005	DIN934-M12				

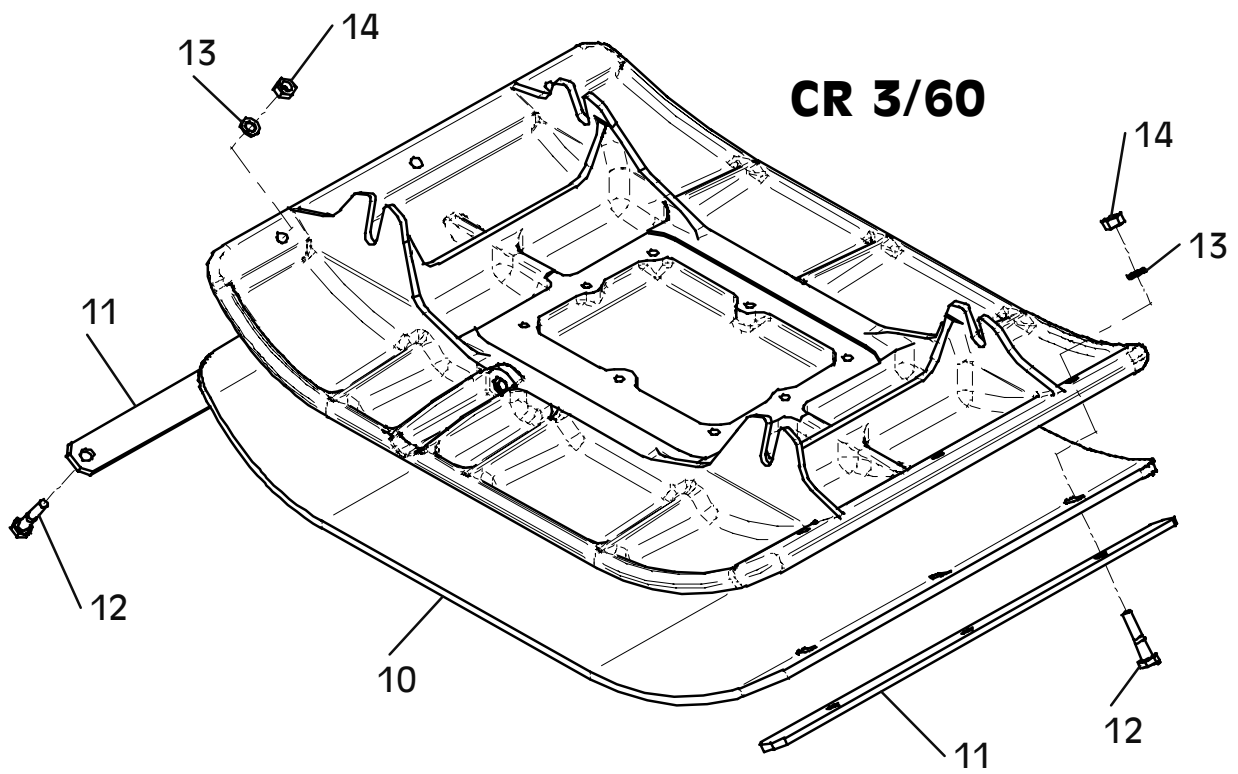
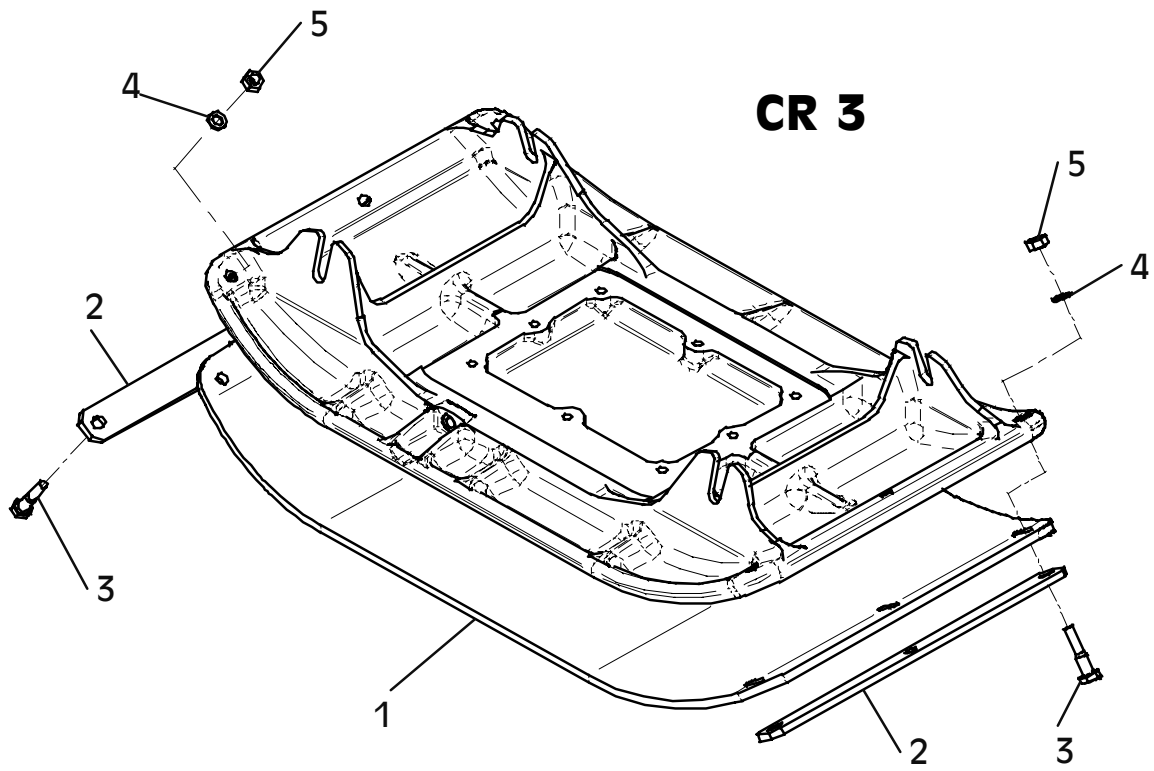

## E 3031-0202

Position Ref.No. Repère Posizione Posicion	Menge Quantity Quantité Quantità Cantidad	Teile-Nr. Part-No. No. Référence Nr. d'Ordine No. Referenzia	Hinweis Hints Indications Indicazione Indicaciones	Position Ref. No. Repère Posizione Posicion	Menge Quantity Quantité Quantità Cantidad	Teile-Nr. Part-No. No. Référence Nr. d'Ordine No. Referenzia	Hinweis Hints Indications Indicazione Indicaciones
1	1	10022502					
2	1	10016239					
3	1	20025508					
4	1	25031004	DIN934-M10				
5	1	25038060	DIN933-M10x50				
6	2	20025007					
7	4	25048006	DIN125-A21				
8	2	25037011					
9	1	10022503					
10	1	25040018	DIN931-M12x50				
11	1	25040033	DIN931-M12x70				
12	2	25048004	DIN125-A13				
13	1	20029004	VSK 12				
14	1	25031005	DIN934-M12				



## E 3032-0202

Position Ref.No. Repère Posizione Posicion	Menge Quantity Quantité Quantità Cantidad	Teile-Nr. Part-No. No. Référence Nr. d'Ordine No. Referenzia	Hinweis Hints Indications Indicazione Indicaciones	Position Ref. No. Repère Posizione Posicion	Menge Quantity Quantité Quantità Cantidad	Teile-Nr. Part-No. No. Référence Nr. d'Ordine No. Referenzia	Hinweis Hints Indications Indicazione Indicaciones
1	1	10022504					
2	1	10016239					
3	1	20025508					
4	1	25031004	DIN934-M10				
5	1	25038060	DIN933-M10x50				
6	2	20025007					
7	4	25048006	DIN125-A21				
8	2	25037011					
9	1	10022503					
10	1	25040018	DIN931-M12x50				
11	1	25040033	DIN931-M12x70				
12	2	25048004	DIN125-A13				
13	1	20029004	VSK 12				
14	1	25031005	DIN934-M12				

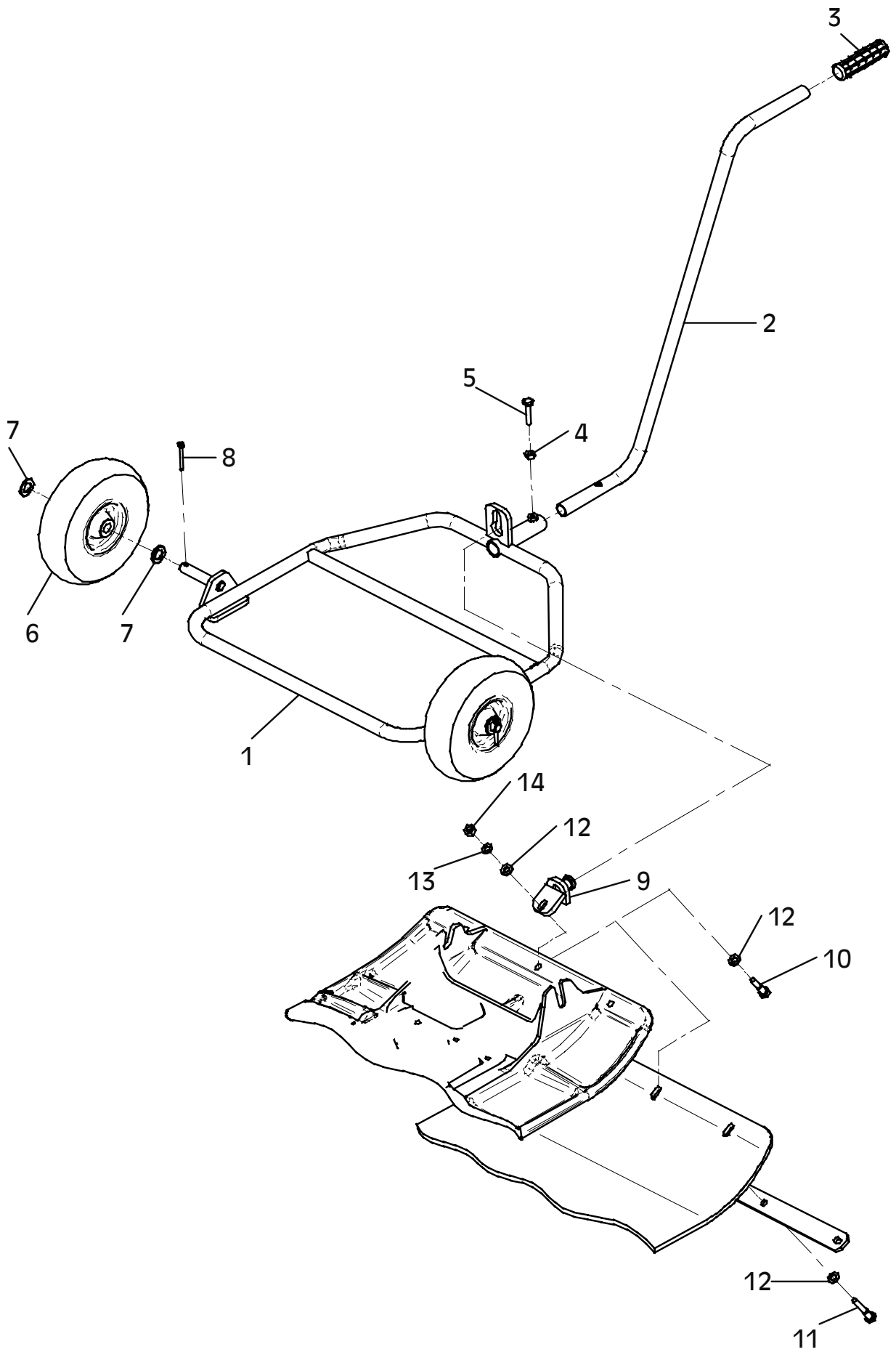

E 3032-0202



**Wenn Sie Fragen und Anregungen haben, oder sonstige Informationen benötigen,  
wenden Sie sich bitte an eine der unten genannten Adressen:**

**For questions and further information refer to one of the  
following addresses:**

<p><b>In Deutschland</b></p> <p><b>In Germany</b></p>	<p>WEBER Maschinenteknik GmbH Postfach 2153 57329 Bad Laasphe – Rückershausen</p> <p>Information / information: E-mail: info@webermt.de</p> <p>Ersatzteile / spare parts: E-mail: parts@webermt.de</p>	<p>Telefon / phone:</p> <p>Telefax / fax:</p> <p>Telefax / fax:</p>	<p>+49 (0) 2754 / 3980 Zentrale / switchboard</p> <p>+49 (0) 2754 / 398101 Zentrale / switchboard</p> <p>+49 (0) 2754 / 398102 Ersatzteile / spare parts direct dial</p>
<p><b>In Holland</b></p> <p><b>In Netherlands</b></p>	<p>WEBER Maschinenteknik B.V. Graafschap Hornelaan 159 6001 AC Weert</p> <p>E-mail: info@webermt.nl</p>	<p>Telefon / phone:</p> <p>Telefax / fax:</p>	<p>+31 (0) 495 / 530215</p> <p>+31 (0) 495 / 541839</p>
<p><b>In Frankreich</b></p> <p><b>In France</b></p>	<p>WEBER Technologie S.A.R.L. 26, rue d'Arsonval 69680 Chassieu</p> <p>E-mail: france@webermt.com</p>	<p>Telefon / phone:</p> <p>Telefax / fax:</p>	<p>+33 (0) 472 / 791020</p> <p>+33 (0) 472 / 791021</p>
<p><b>In Polen</b></p> <p><b>In Poland</b></p>	<p>WEBER Maschinenteknik SP.ZO.O. ul. Grodziska 7 05-830 Stara Wies / Nadarzyn</p> <p>E-mail: info@webermt.com.pl</p>	<p>Telefon / phone:</p> <p>Telefax / fax:</p>	<p>+48 (0) 22 / 7397080 +48 (0) 22 / 7397081</p> <p>+48 (0) 22 / 7397082</p>
<p><b>In USA, Kanada</b></p> <p><b>In USA, Canada</b></p>	<p>WEBER Machine (USA), Inc. 40 Johnson Ave 112 Bangor, ME 04401 USA</p> <p>E-mail: usa@webermt.com</p>	<p>Telefon / phone:</p> <p>Telefax / fax:</p>	<p>+1 (0) 207 / 9474990</p> <p>+1 (0) 207 / 9475452</p>
<p><b>In Südamerika</b></p> <p><b>In South America</b></p>	<p>WEBER Maschinenteknik do Brasil Ltda. Rua Sete de Setembro, 275 93332-470 Novo Hamburgo, RS Brasil</p> <p>E-mail: webermt@webermt.com.br</p>	<p>Telefon / phone:</p> <p>Telefax / fax:</p>	<p>+55 (0) 51 / 5873044</p> <p>+55 (0) 51 / 5872271</p>

<http://www.webermt.com>

