



ERSATZTEILLISTE

SPARE PARTS LIST

LISTE DES PIECES  
DE RECHANGE

LISTINO RICAMBI

LISTA DE RECAMBIOS

WYKAZ CZESCI  
ZAMIENNYCH



**CR 3**

**CR 3 / 60**

Honda GX 270

Robin EH 25



Weber Maschinenteknik GmbH  
Postfach 2153, 57329 Bad Laasphe-Rückershausen  
Telefon 02754 / 398-0

Telefax (02754) 398-101 (Zentrale) u. 398-102 (Ersatzteile)

**EG - KONFORMITÄTSEKTLÄRUNG**  
EC DECLARATION OF CONFORMITY/ DECLARATION DE CONFORMITE CE  
DICHIARAZIONE CE DI CONFORMITA / DECLARACION CE DE CONFORMIDAD  
EG-VERKLARING VAN OVEREENSTEMMING / EF-OVERENSSTEMMELSESEKKAERING  
DECLARACAO CE DE CONFORMIDADE / EG-FÖRSÄKRAN OM ÖVERENSSTÄMMELSE

**im Sinne der EG-Maschinenrichtlinie 98/37/EG  
und der EG Richtlinie 2000/14/EG – Geräuschemissionen**

- I **Art / Category / Catégorie / Categoria Tipo / Kategori /**  
Soort / Categoria / kategori
- II **Hersteller (Typ) / Make (Type) / Marque (Type) / Marca (Tipo) /**  
Marca (Codice) / Producent (Type) / Merk (Type) / Marca (Tipo) /  
Tillverkare (Typ)
- III **gemessener Schalleistungspegel / measured sound power level / niveau de**  
puissance acoustique mesure / livello di potenza sonora rilevato / nivel de  
potencia acústica medido / gemeten geluidsvermogensniveau / målt  
lydeffektniveau / Nivel de potência sonora midido / uppmätt ljudeffektnivå
- IV **garantierter Schalleistungspegel / guaranteed sound power level / niveau de**  
puissance acoustique garanti / livello di potenza sonora garantito / nivel de  
potencia acustica garantizado / gewaarborgd geluidsvermogensniveau /  
garanteret lydeffektniveau / Nivel sonoro garantido / garanterad ljudeffektniva
- V **beteiligte Zertifizierungsstelle / notified body involved / de l'organisme**  
notifié/ dell'organismo notificato che l'ha effettuata / dirección del organismo  
notificado que haya intervenido / betrokken aangemelde instantie / pagældende  
bemyndigede organ / organismo notificado envolvido / berörda anmälda  
organets namn
- VI **Konformitäts-Bewertungsverfahren / Conformity assessment procedure**  
followed / la procédure appliquée pour l'évaluation de la conformité et /  
procedura di valutazione della conformità / procedimiento de evaluación de la  
conformidad / gevolgde overeenstemmingsbeoordelingsprocedure / den fulgte  
overensstemmelssesvurderingsprocedure / procedimento de avaliacao de  
conformidade / Vilket förfarande för bedömning av överensstämmelse

**Vibrationsplatte  
CR 3 R-Hd**



**LWA = 107 dB (A)**

**LWA = 108 dB (A)**

**RWTÜV  
Postfach 103161  
D-45032 Essen**

**interne Fertigungskontrolle  
nach Anhang VI  
EG Richtlinie 2000/14/EG**

**ist in Übereinstimmung mit folgenden Richtlinien hergestellt worden /has een produced in accordance with following standards / est produit conforme aux dispositions des directives europeenes ci-apres / ha sido fabricado en conformidad con las siguientes normas / é stato fabbricato in conformità alle sequenti norme / er blevet fremstillet i overensstemmelse med følgende retningslinier / in overeenstemming met de volgende voorschriften gefabriceerd is / é fabricado conforme as seguintes normas / har tillverkats i överensstämmelse med följande riktlinjer**

<b>98/37/EG</b>	Maschinenrichtlinie des europäischen Parlamentes und des Rates vom 22. Juni 1998
<b>2000/14/EG</b>	EG-Richtlinie Geräuschemissionen vom 8. Mai 2000
<b>EN 500 Teil 1</b>	Bewegliche Straßenbaumaschinen – Sicherheit Gemeinsame Anforderungen
<b>EN 500 Teil 4</b>	Bewegliche Straßenbaumaschinen – Sicherheit Besondere Anforderungen an Verdichtungsmaschinen

**Bescheinigung bitte sorgfältig aufbewahren / File certificate carefully / Conserver certificat soigneusement / Conservar certificado cuidadosamente / Pregasi conservare accuratamente certificato / Beviset bedes opbevares omhyggeligt / Verklaring a.u.b. zorgvuldig bevar / Conservar o certificado com cuidado / Beviset skall om sorgsfullt bevaras**

Bad Laasphe – Rückershausen, den **02.01.2002**

W. Weber, Geschäftsführer



**WEBER Maschinentechnik GmbH**  
Im Boden 5-8, 10 – D-57334 Bad Laasphe  
Postfach 2153 – D-57329 Bad Laasphe  
Telefon: 02754/398-0 – Fax 02754/398-101  
E-mail: [Verkauf@webermt.de](mailto:Verkauf@webermt.de)  
Internet: <http://www.webermt.de>



BITTE, NOTIEREN SIE SERIENNUMMER UND MOTORNUMMER IHRER MASCHINE:

PLEASE WRITE DOWN SERIALNUMBERS OF MACHINE AND ENGINE:

NOTEZ SVP LE NUMERO DE SERIE ET LE NUMERO DU MOTEUR DE VOTRE MACHINE:

SI PREGA DI ANNOTARE SEMPRE I NUMERI DI SERIE SIA DELLA VS. MACCHINA CHE DEL MOTORE:

MAQUINA: ROGAMOS ANOTEN EL NUMERO DE SERIE Y NUMERO DE MOTOR DE SU MAQUINA:

MASCHINE  
MACHINE  
MACCHINA  
MAQUINA

MOTOR  
ENGINE  
MOTEUR  
MOTORE

ZUR VERMEIDUNG VON FEHLLIEFERUNGEN UND VERZÖGERUNGEN SIND BEI DER BESTELLUNG VON ERSATZTEILEN FOLGENDE ANGABEN UNBEDINGT ERFORDERLICH:

- MASCHINENTYP
- SERIENNUMMER DER MASCHINE
- SERIENNUMMER DES MOTORS (BEI MOTORTEILEN)
- TEILENUMMER
- BESTELLMENGE

TO AVOID ERRORS IN DELIVERY PLEASE STATE THESE PARTICULARS WHEN ORDERING:

- TYPE OF MACHINE
- SERIAL NO. OF MACHINE
- SERIAL NO. OF ENGINE (ON ENGINE PARTS)
- PART-NO.
- QUANTITY REQUIRED

AFIN D'EVITER DES ERREURS DE COMMANDE ET DES RETARDS DE LIVRAISON IL EST NECESSAIRE D'INDIQUER LES CARACTERISTIQUES SUIVANTES:

- TYPE DE MACHINE
- LE NUMERO DE SERIE DE LA MACHINE
- LE NUMERO DE SERIE DU MOTEUR
- LE NUMERO D'IDENTITE DE LA PIECE
- LA QUANTITE SOUHAITEE

ONDE EVITARE DISGUIDI E RITARDI NELLE CONSEGNE DIE RICAMBI SI PREGA DI INDICARE SEMPRE:

- TIPO DELLA MACCHINA
- NUMERO DI SERIE DELLA MACCHINA
- NUMERO DI SERIE DEL MOTORE (SE SI RICHIEDONO PEZZI DEL MOTORE)
- NUMERO D'ORDINE DIE SINGOLI RICAMBI
- QUANTITA

A FI DE EVITAR ERRORES DE ENTREGA, ROGAMOS INDIQUEN LOS SIGUIENTES DATOS CUANDO PASE PEDIDOS DE RECAMBIO:

- MODELO DE MAQUINA
- NO. DE SERIE DE LA MAQUINA
- NO. DE SERIE DEL MOTOR (EN PIEZAS PARA MOTOR)
- REFERENCIA DEL RECAMBIO
- CANTIDAD PEDIDA

## E 2005-0700

Position Ref.No. Repère Posizione Posicion	Menge Quantity Quantité Quantità Cantidad	Teile-Nr. Part-No. No. Référence Nr. d'Ordine No. Referenzia	Hinweis Hints Indications Indicazione Indicaciones	Position Ref. No. Repère Posizione Posicion	Menge Quantity Quantité Quantità Cantidad	Teile-Nr. Part-No. No. Référence Nr. d'Ordine No. Referenzia	Hinweis Hints Indications Indicazione Indicaciones
1	1	10016003	CR 3				
2	1	25030002	DIN908-M14 x1,5-5.8				
3	1	10001413					
4	6	25045015	DIN912-M12x90-10.9				
5	2	25045027	DIN912-M12x150-10.9				
6	8	20029026					
7	4	20004011					
8	4	20029023					
9	4	25031005	DIN934-M12-8				
10	4	25038018	DIN933-M12x20-8.8				
11	4	20029004	VSK 12				
12	1	20013277					

CR 3

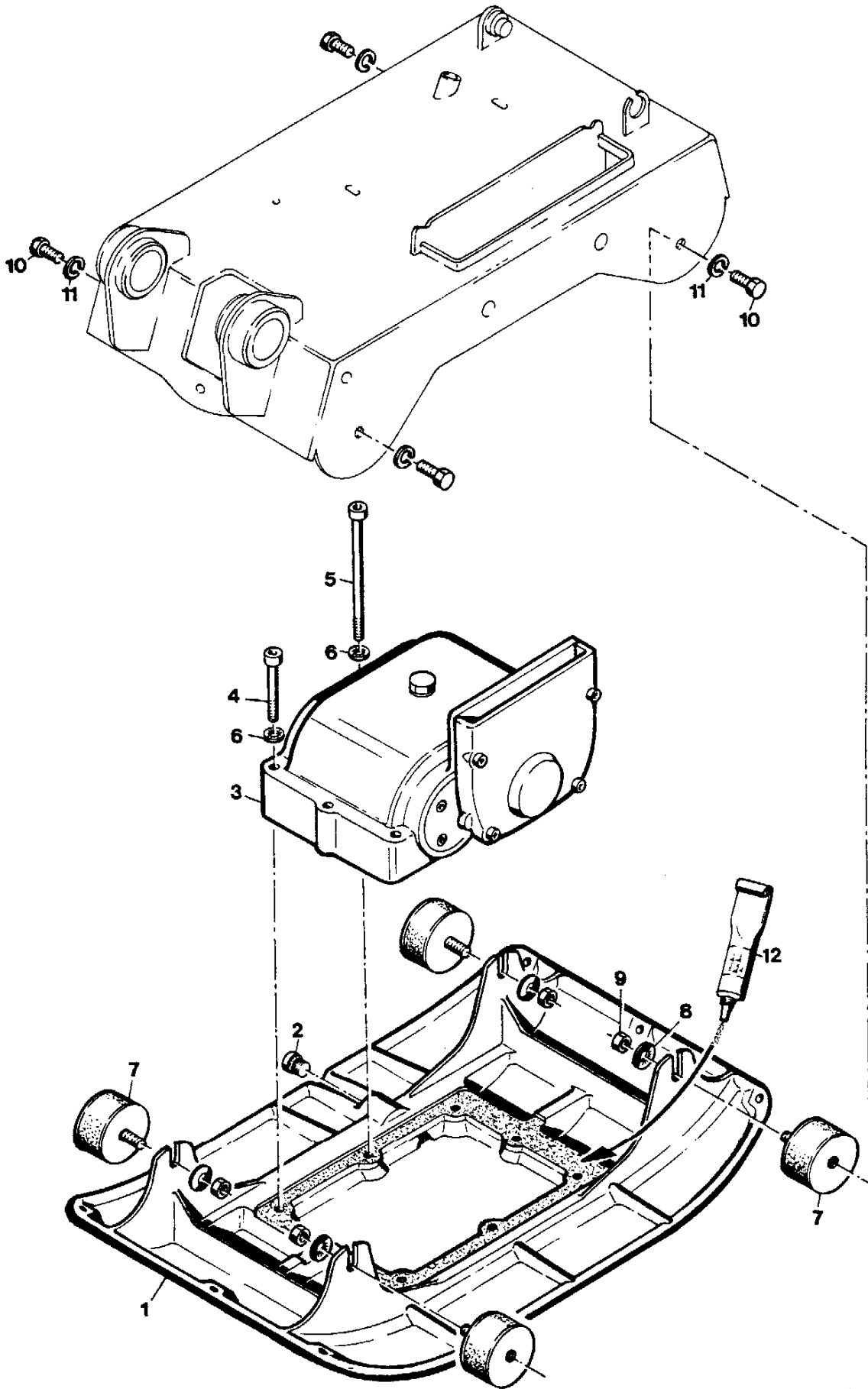

E2005-0700

## E2011-0700

Position Ref.No. Repère Posizione Posicion	Menge Quantity Quantité Quantità Cantidad	Teile-Nr. Part-No. No. Référence Nr. d'Ordine No. Referenzia	Hinweis Hints Indications Indicazione Indicaciones	Position Ref. No. Repère Posizione Posicion	Menge Quantity Quantité Quantità Cantidad	Teile-Nr. Part-No. No. Référence Nr. d'Ordine No. Referenzia	Hinweis Hints Indications Indicazione Indicaciones
1	1	10016004	CR 3 / 60				
2	1	25030002	DIN908-M14x1,5-5.8				
3	1	10001413					
4	6	25045015	DIN912-M12x90-10.9				
5	2	25045027	DIN912-M12x150-10.9				
6	8	20029026					
7	4	20004011					
8	4	20029023					
9	4	25031005	DIN934-M12-8				
10	4	25038018	DIN933-M12x20-8.8				
11	4	20029004	VSK 12				
12	1	20013277					

CR 3 / 60

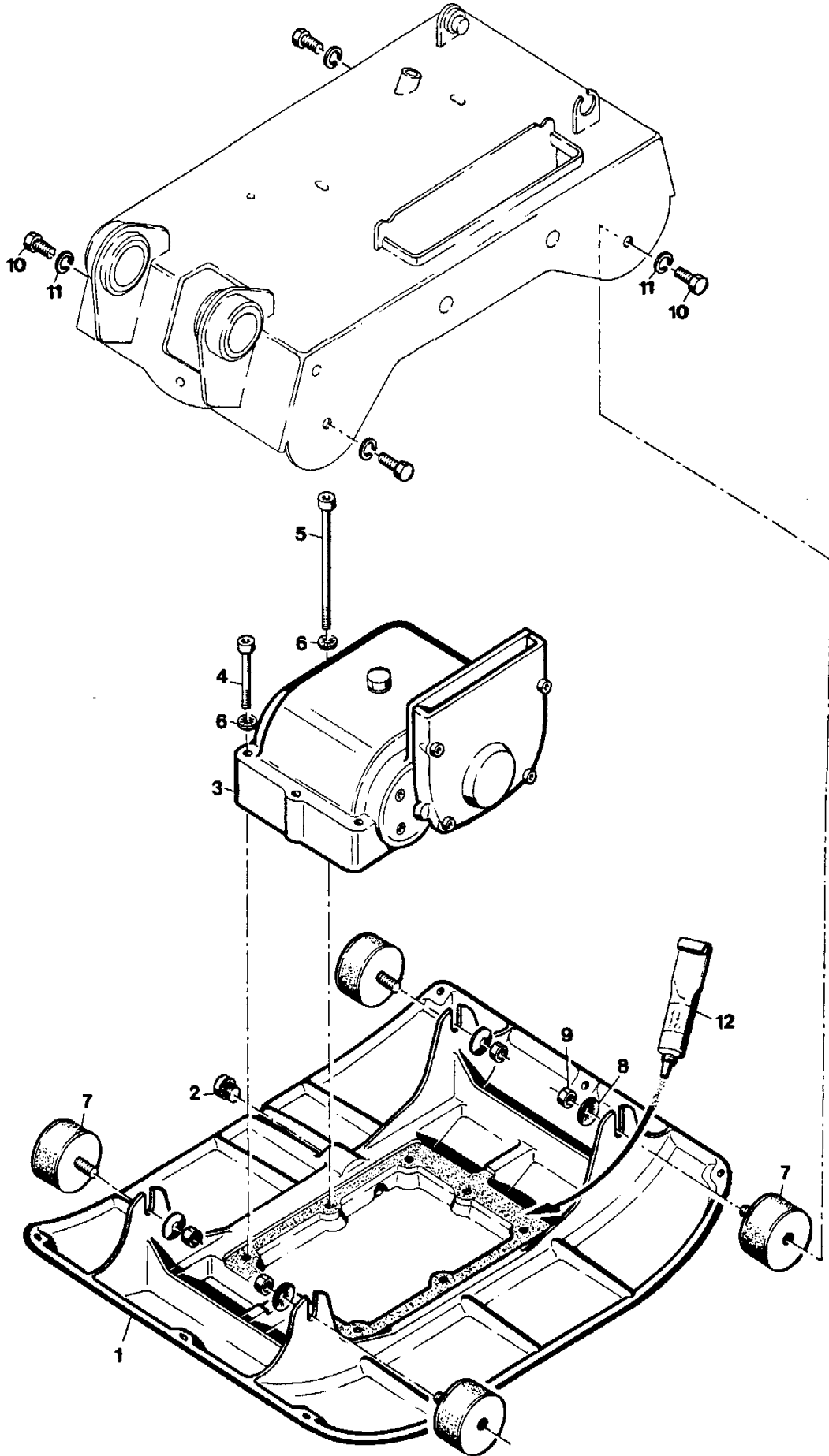

E2011-0700

## E2006-0700

Position Ref.No. Repère Posizione Posicion	Menge Quantity Quantité Quantità Cantidad	Teile-Nr. Part-No. No. Référence Nr. d'Ordine No. Referenzia	Hinweis Hints Indications Indicazione Indicaciones	Position Ref. No. Repère Posizione Posicion	Menge Quantity Quantité Quantità Cantidad	Teile-Nr. Part-No. No. Référence Nr. d'Ordine No. Referenzia	Hinweis Hints Indications Indicazione Indicaciones
1	1	10016054		30	1	10016067	
2	1	25039005	DIN933-M12x20-8.8	31	1	10016063	
3	1	25008011	DIN7603-A12x18x1,5-Cu	32	2	25001022	
4	2	10016060		33	2	10016074	
5	4	20013269		34	1	10008320	
6	8	25044100	DIN912-M8x16-8.8	35	1	10016065	
7	8	20029011	VSKZ 8	36	1	25027004	DIN914-M8x16-45H
8	1	10016061		37	1	25001513	
9	1	25017047		38	1	25034002	DIN471-12x1
10	4	25046015	DIN6912-M8x16-8.8	39	1	25035026	DIN472-28x1,2
11	4	20029011	VSKZ 8	40	1	10016066	
12	1	10016070		41	1	20013270	
13	1	10007370		42	1	10016064	
14	1	20029001	VSK 10	43	4	25044100	DIN912-M8x16-8.8
15	1	10016071		44	4	20029011	VSKZ 8
16	1	10016072		45	1	25030016	DIN910-M10x1-St
17	4	25044008	DIN912-M8x40-8.8	46	1	25008012	DIN7603- A10x16x1-Cu
18	4	20029011	VSKZ 8	47	1	20020119	
19	*	20025528	DIN988-56x72x0,1				
20	*	20025029	DIN988-56x72x0,2				
21	*	20025378	DIN988-56x72x0,5				
22	4	25001151					*) je nach Bedarf
23	1	10016068					according to requirement
24	1	25015046	DIN6885-A10x8x28				selon les besoins
25	1	10016062					segun necesidades
26	2	10016069					se necessario
27	2	10016109					
28	4	25045028	DIN912-M10x35-10.9				
29	4	25025245	DIN6796-10				

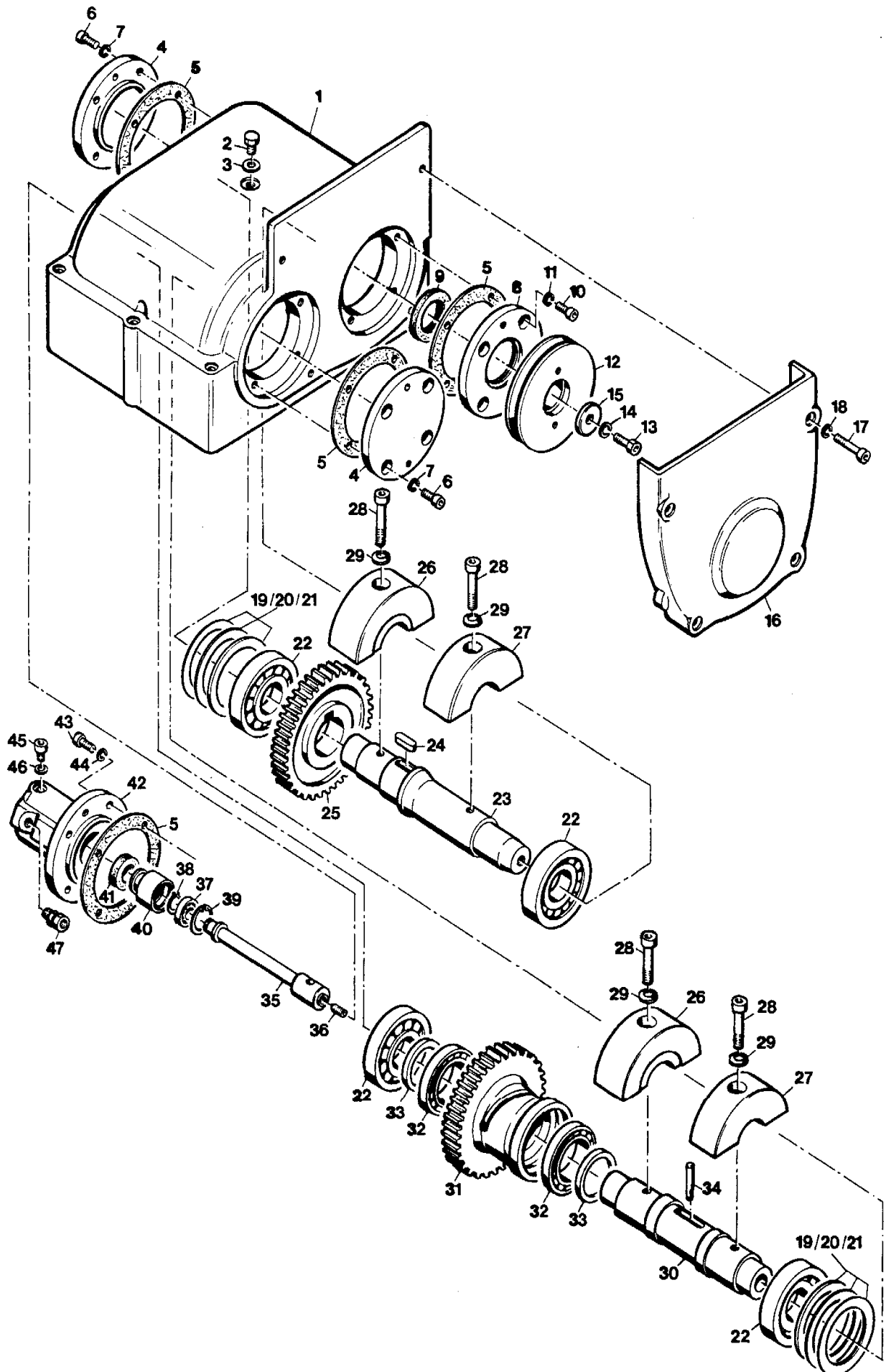

E 2006-0700

## E 2101-0401

Position Ref.No. Repère Posizione Posicion	Menge Quantity Quantité Quantita Cantidad	Teile-Nr. Part-No. No. Référence Nr. d'Ordine No. Referenzia	Hinweis Hints Indications Indicazione Indicaciones	Position Ref. No. Repère Posizione Posicion	Menge Quantity Quantité Quantita Cantidad	Teile-Nr. Part-No. No. Référence Nr. d'Ordine No. Referenzia	Hinweis Hints Indications Indicazione Indicaciones
1	1	10022246		30	4	25044060	DIN912-M8x80
2	1	20005004		31	4	20029011	VSKZ 8
3	2	25049016	DIN440-R9	32	1	20026204	
4	1	20029003	VSK 8	33	1	25008011	
5	1	25031003	DIN934-M8	34	1	25038002	DIN933-M6x16
6	1	25009021		35	1	20029007	VSK 6
7	1	20025434		36	1	25048001	DIN125-B6,4
8	1	20025704		37	1	20007007	
9	1	25038003	DIN933-M6x20	38	1	40001338	
10	1	25048001	DIN125-B6,4	39	1	20026383	
11	1	20007007		40	1	10022249	
12	1	20029007	VSK 6	41	4	25038020	DIN933-M12x30
13	1	25031002	DIN934-M6	42	4	20029004	VSK 12
14	1	20001230	Honda GX 270	43	1	20026465	
15	2	10016212		44	2	25025191	
16	4	25033013	DIN603-M10x50	45	2	20025019	
17	4	25048010	DIN1440-11x25x3	46	1	20025690	
18	4	20029025					
19	4	25031004	DIN934-M10				
20	1	25015014					
21	1	10022501					
22	4	25038007	DIN933-M8x20				
23	4	20029003	VSK 8				
24	1	20002084					
25	1	25044007	DIN912-M8x30				
26	1	20029011	VSKZ 8				
27	1	20026475					
28	1	25002057					
29	1	10016028					

# Honda GX 270

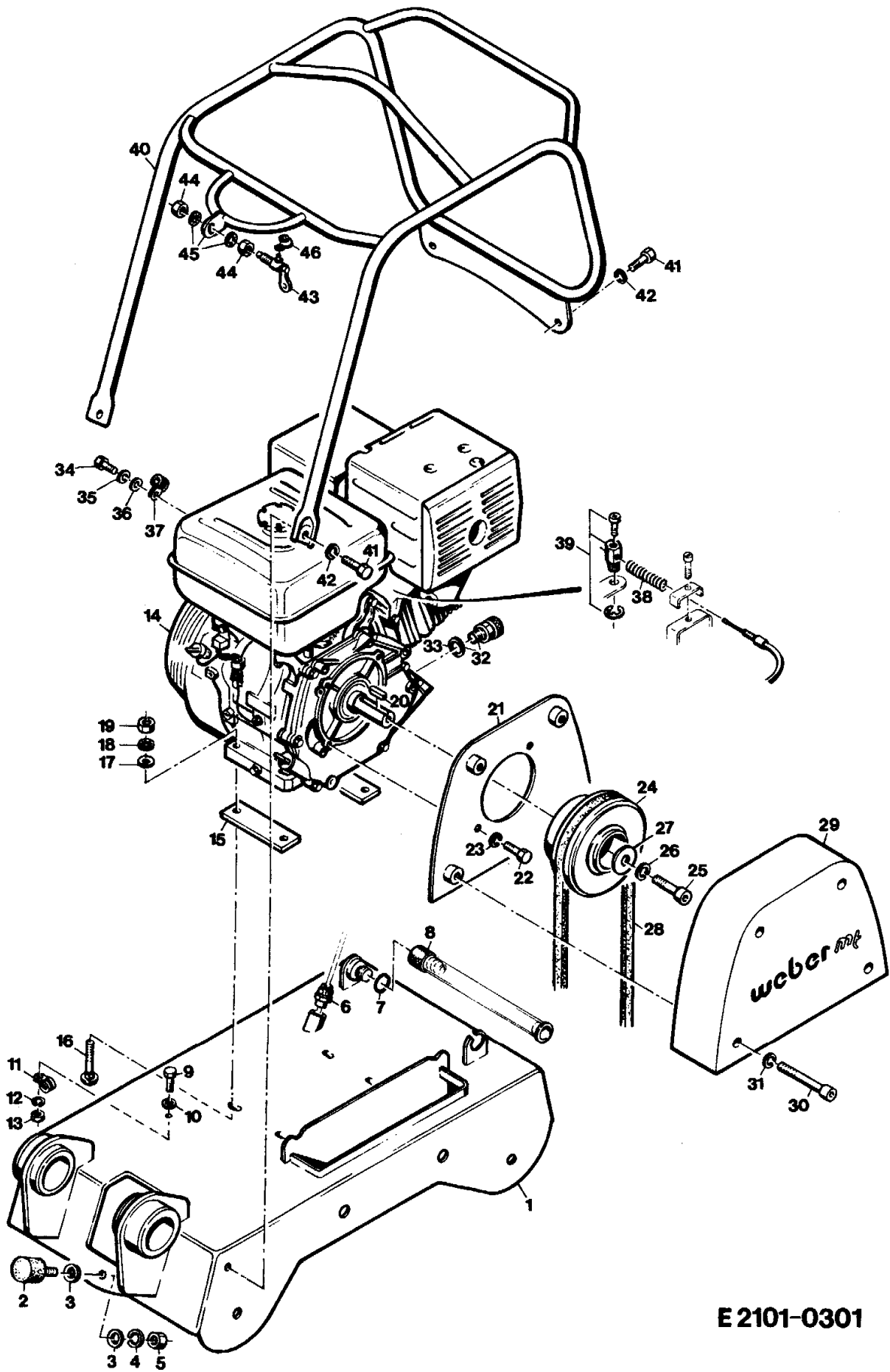

E 2101-0301

## E2100-0401

Position Ref.No. Repère Posizione Posicion	Menge Quantity Quantité Quantita Cantidad	Teile-Nr. Part-No. No. Référence Nr. d'Ordine No. Referenzia	Hinweis Hints Indications Indicazione Indicaciones	Position Ref.No. Repère Posizione Posicion	Menge Quantity Quantité Quantita Cantidad	Teile-Nr. Part-No. No. Référence Nr. d'Ordine No. Referenzia	Hinweis Hints Indications Indicazione Indicaciones
1	1	10022246		30	4	25044060	DIN912-M8x80
2	1	20005004		31	4	20029011	VSKZ 8
3	2	25049016	DIN440-R9	32	2	25031002	DIN934-M6
4	2	20029003	VSK 8	33	1	20025702	
5	1	25031003	DIN934-M8	34	1	25008006	
6	1	25009021		35	1	10022247	
7	1	20025434		36	4	25038020	DIN933-M12x30
8	1	20025704		37	4	20029004	VSK 12
9	1	25038003	DIN933-M6x20	38	1	20026465	
10	1	25048001	DIN125-B6,4	39	2	25025191	
11	1	20007007		40	2	20025019	
12	1	20029007	VSK 6	41	1	20025690	
13	1	25031002	DIN934-M6				
14	1	20001229	Robin EH 25				
15	1	30047162					
16	4	25033018	DIN603-M10x55				
17	4	25048010	DIN1440-11x25x3				
18	6	20029025					
19	6	25031004	DIN934-M10				
20	2	25033025					
21	1	10022248					
22	4	25038006	DIN933-M8x16				
23	4	20029003	VSK 8				
24	1	20002084					
25	1	25044005	DIN912-M8x20				
26	1	20029011	VSKZ 8				
27	1	20026475					
28	1	25002056					
29	1	10016028					

# Robin EH 25

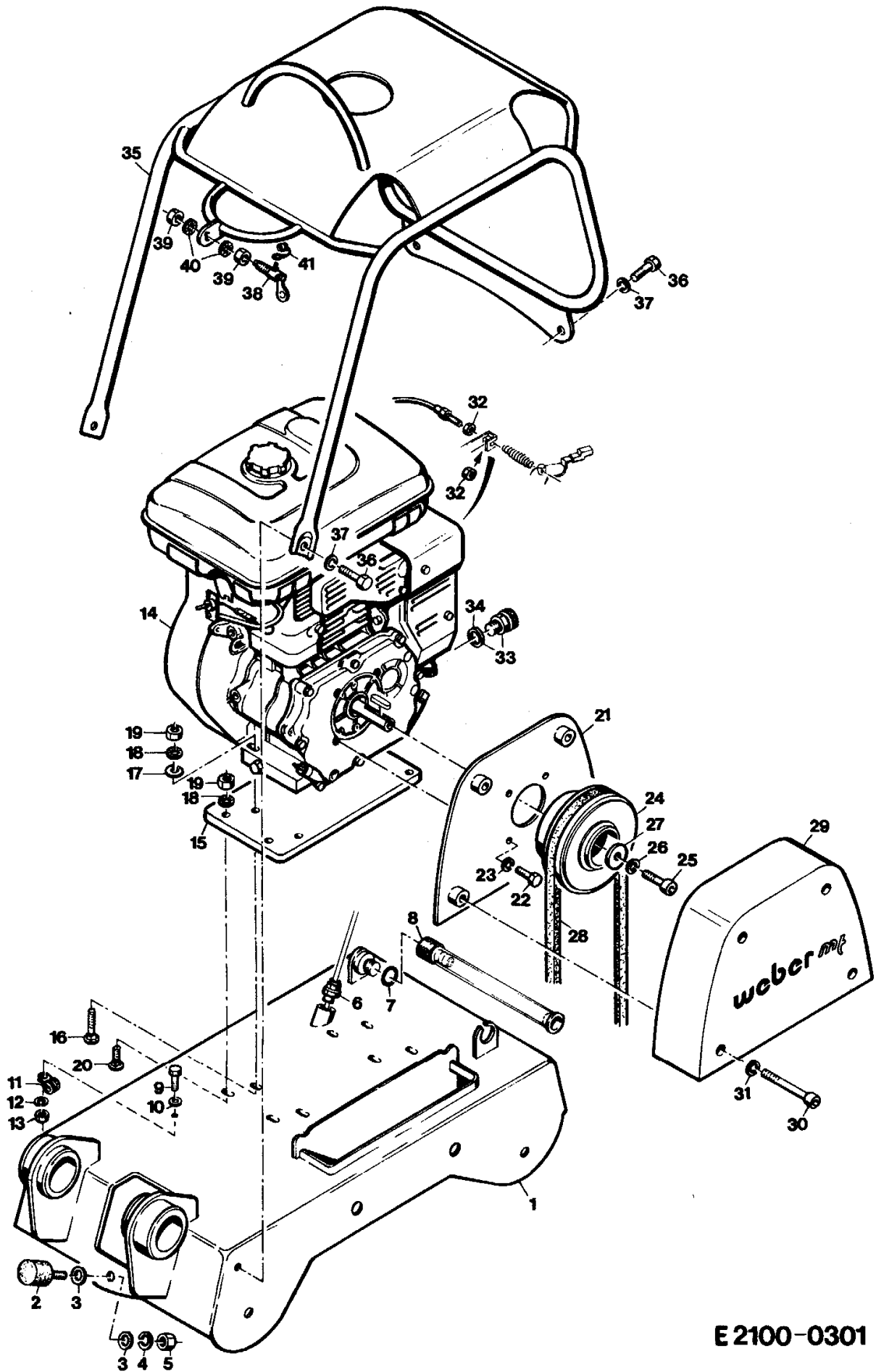

E 2100-0301

## E 2009-0700

Position Ref.No. Repère Posizione Posicion	Menge Quantity Quantité Quantità Cantidad	Teile-Nr. Part-No. No. Référence Nr. d'Ordine No. Referenzia	Hinweis Hints Indications Indicazione Indicaciones	Position Ref. No. Repère Posizione Posicion	Menge Quantity Quantité Quantità Cantidad	Teile-Nr. Part-No. No. Référence Nr. d'Ordine No. Referenzia	Hinweis Hints Indications Indicazione Indicaciones
1	1	10016011		30	1	10022230	
2	1	25030003	DIN908-M24x1,5-5.8	31	1	25009021	
3	1	25008008	DIN7603-A24x32x2-Cu	32	2	10016099	
4	1	20018134		33	2	20004036	
5	1	10016100		34	4	20033002	
6	2	25040067	DIN931-M6x30-8.8	35	2	25048012	DIN9021-13
7	2	20029007	VSK 6	36	2	20029013	VSKZ 12
8	1	20018021		37	2	25044066	DIN912-M12x90-8.8
9	1	20006410		38	1	10016017	
10	1	10016023		39	1	20007202	
11	2	10016101					
12	2	20013271					
13	2	20013272					
14	2	10022231					
15	2	20029023					
16	2	25038018	DIN933-M12x20-8.8				
17	2	20026468					
18	1	20008067					
19	1	10016022					
20	1	20013275					
21	1	10016102					
22	2	20013273					
23	1	10016103					
24	1	20013274					
25	1	30047092					
26	1	20020119					
27	1	20016364					
28	4	25044007	DIN912-M8x30-8.8				
29	4	20029011	VSKZ 8				

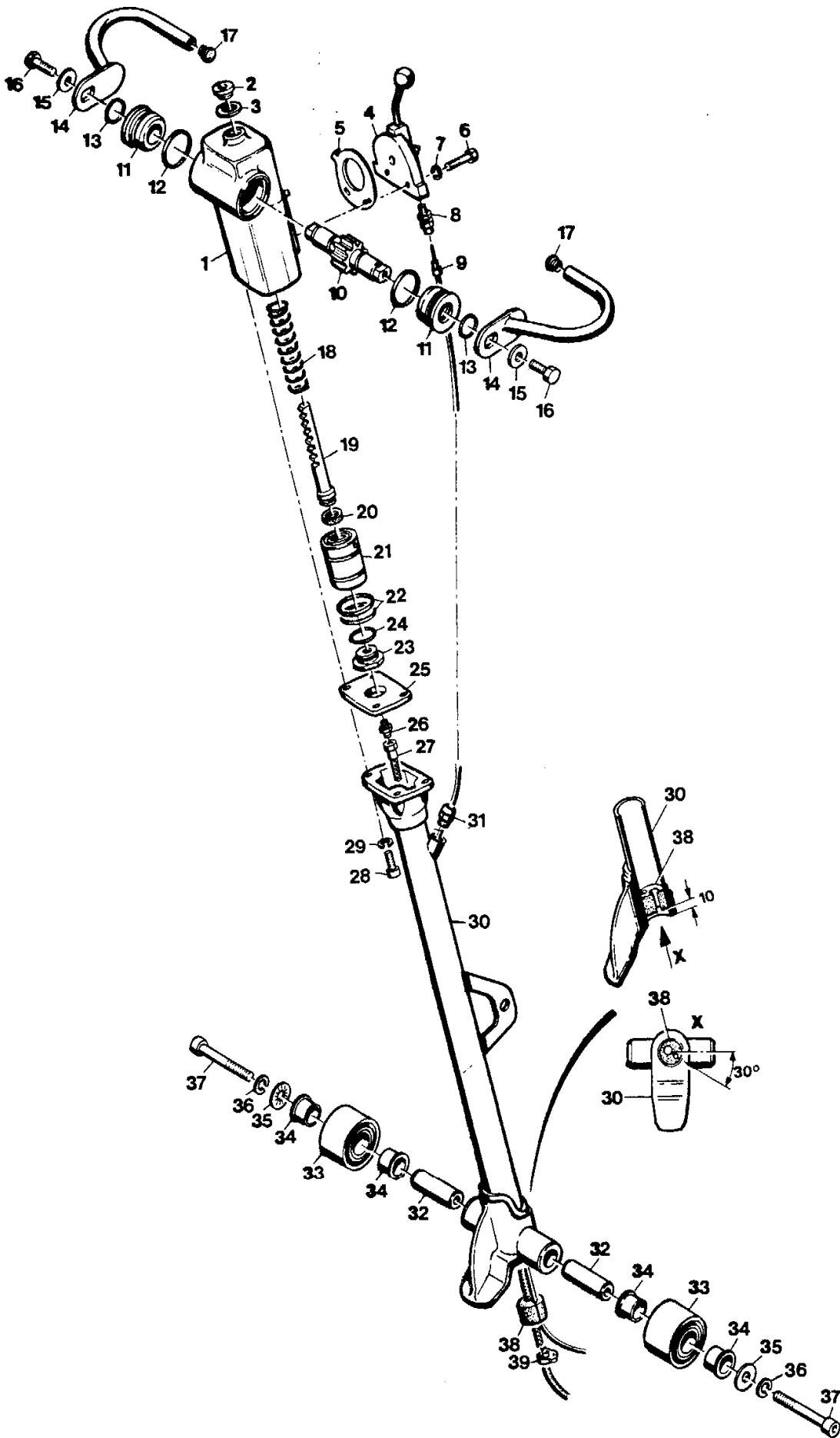

E2009-0700

## E 2010-0700

Position Ref.No. Repère Posizione Posicion	Menge Quantity Quantité Quantità Cantidad	Teile-Nr. Part-No. No. Référence Nr. d'Ordine No. Referenzia	Hinweis Hints Indications Indicazione Indicaciones	Position Ref. No. Repère Posizione Posicion	Menge Quantity Quantité Quantità Cantidad	Teile-Nr. Part-No. No. Référence Nr. d'Ordine No. Referenzia	Hinweis Hints Indications Indicazione Indicaciones
1	1	10016113					
2	2	10016114					
3	6	25040019	DIN931-M12x55-8.8				
4	6	20029004	VSK 12				
5	6	25031005	DIN934-M12-8				
6	1	10016115					
7	2	10016116					
8	6	25040019	DIN931-M12x55-8.8				
9	6	20029004	VSK 12				
10	6	25031005	DIN934-M12-8				

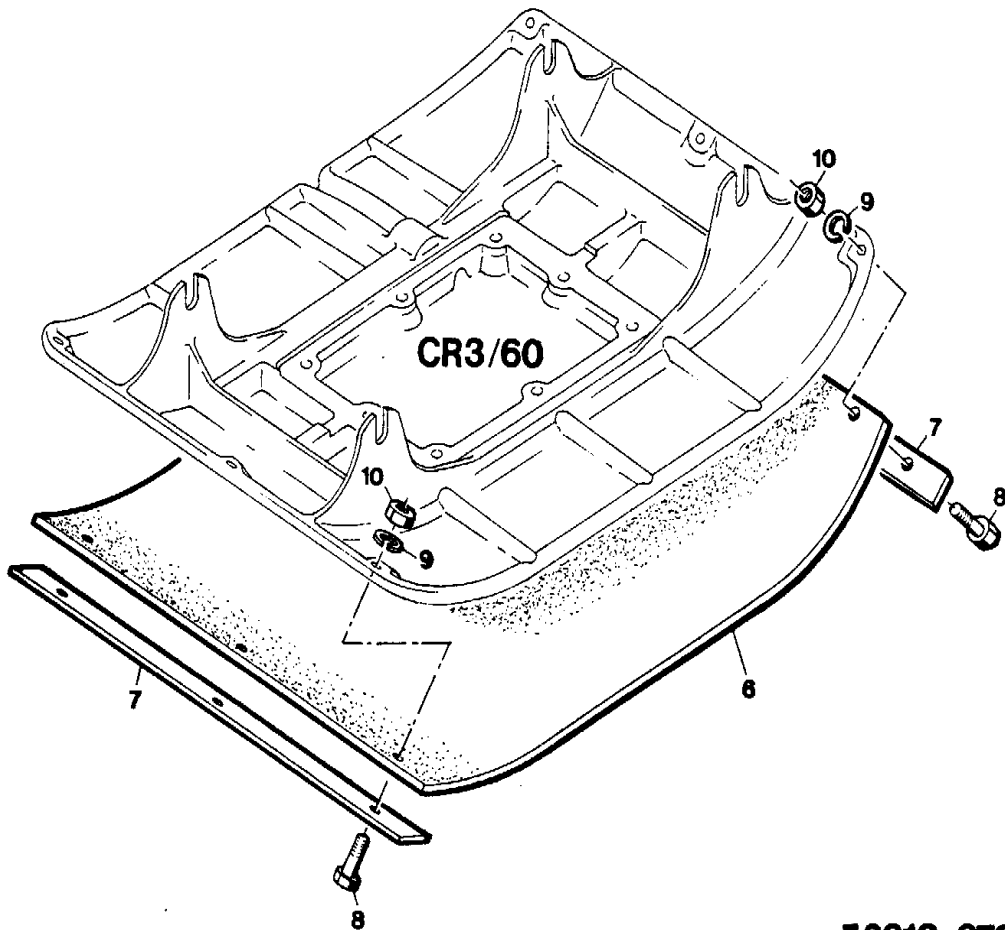
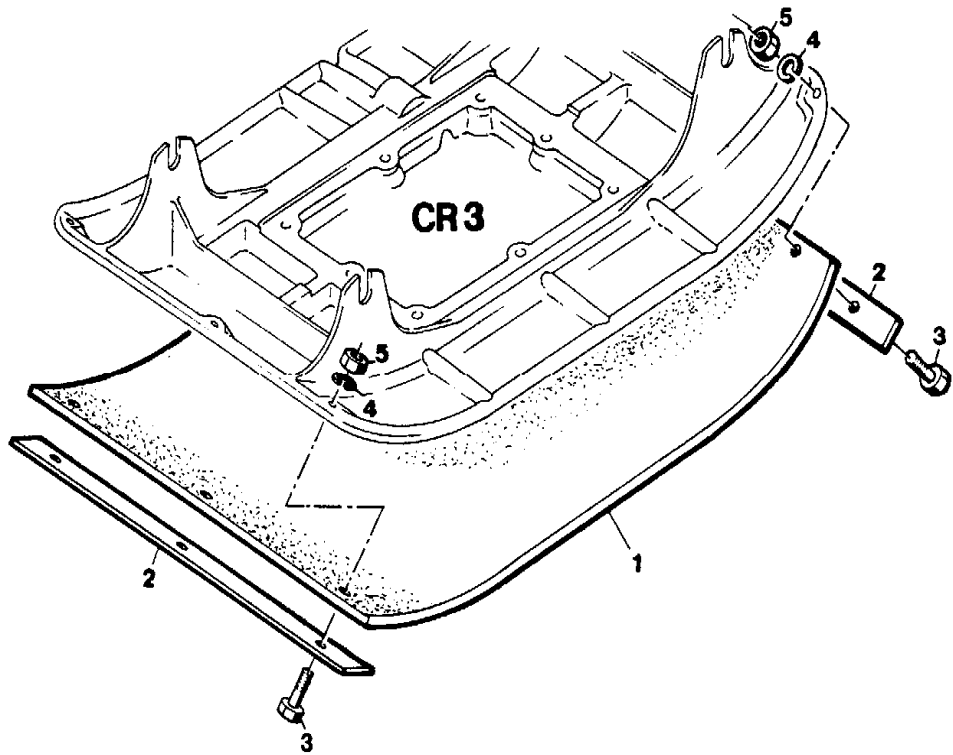

E2010-0700

## E2059-0101

Position Ref.No. Repère Posizione Posicion	Menge Quantity Quantité Quantità Cantidad	Teile-Nr. Part-No. No. Référence Nr. d'Ordine No. Referenzia	Hinweis Hints Indications Indicazione Indicaciones	Position Ref. No. Repère Posizione Posicion	Menge Quantity Quantité Quantità Cantidad	Teile-Nr. Part-No. No. Référence Nr. d'Ordine No. Referenzia	Hinweis Hints Indications Indicazione Indicaciones
<b>CR 3</b>				<b>CR 3 / 60</b>			
		<b><u>000019016</u></b>				<b><u>000019017</u></b>	
1	1	20025508		1	1	20025508	
2	1	10016239		2	1	10016239	
3	1	25038060	DIN933-M10x50	3	1	25038060	DIN933-M10x50
4	1	25031004	DIN934-M10	4	1	25031004	DIN934-M10
5	1	10022502		5	1	10022504	
6	4	25048006	DIN125-A21	6	4	25048006	DIN125-A21
7	2	20025007		7	2	20025007	
8	2	25037011		8	2	25037011	
9	1	10022503		9	1	10022503	
10	1	25040018	DIN931-M12x50 ohne Vulkollanplatte	10	1	25040018	DIN931-M12x50 ohne Vulkollanplatte
	1	25040033	DIN931-M12x70 mit Vulkollanplatte		1	25040033	DIN931-M12x70 mit Vulkollanplatte
11	1	25048004	DIN125-A13	11	1	25048004	DIN125-A13
12	1	20029004	VSK 12	12	1	20029004	VSK 12
13	1	25031005	DIN934-M12	13	1	25031005	DIN934-M12

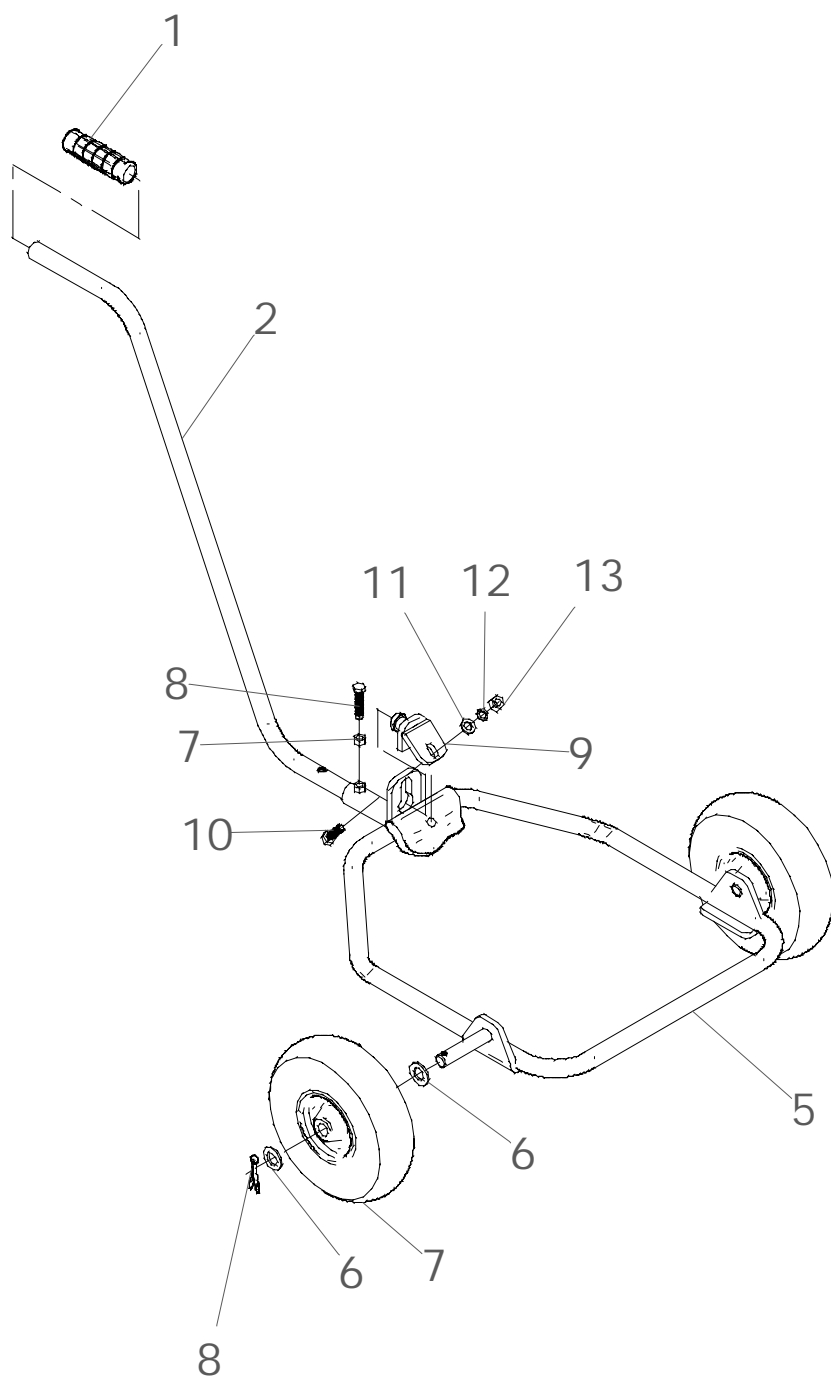

E 2059-0101



**Wenn Sie Fragen und Anregungen haben, oder sonstige Informationen benötigen,  
wenden Sie sich bitte an eine der unten genannten Adressen:**

**For questions and further information refer to one of the  
following addresses:**

<p><b>In Deutschland</b></p> <p><b>In Germany</b></p>	<p>WEBER Maschinentchnik GmbH Postfach 2153 57329 Bad Laasphe – Rückershausen</p> <p>Information / information: E-mail: info@webermt.de Ersatzteile / spare parts: E-mail: parts@webermt.de</p>	<p>Telefon / phone:</p> <p>Telefax / fax:</p> <p>Telefax / fax:</p>	<p>+49 (0) 2754 / 3980 Zentrale / switchboard</p> <p>+49 (0) 2754 / 398101 Zentrale / switchboard</p> <p>+49 (0) 2754 / 398102 Ersatzteile / spare parts direct dial</p>
<p><b>In Holland</b></p> <p><b>In Netherlands</b></p>	<p>WEBER Maschinentchnik B.V. Graafschap Hornelaan 159 6001 AC Weert</p> <p>E-mail: info@webermt.nl</p>	<p>Telefon / phone:</p> <p>Telefax / fax:</p>	<p>+31 (0) 495 / 530215</p> <p>+31 (0) 495 / 541839</p>
<p><b>In Frankreich</b></p> <p><b>In France</b></p>	<p>WEBER Technologie S.A.R.L. 26, rue d' Arsonval 69680 Chassieu</p> <p>E-mail: france@webermt.com</p>	<p>Telefon / phone:</p> <p>Telefax / fax:</p>	<p>+33 (0) 472 / 791020</p> <p>+33 (0) 472 / 791021</p>
<p><b>In Polen</b></p> <p><b>In Poland</b></p>	<p>WEBER Maschinentchnik SP.ZO.O. ul. Grodziska 7 05-830 Stara Wies / Nadarzyn</p> <p>E-mail: info@webermt.com.pl</p>	<p>Telefon / phone:</p> <p>Telefax / fax:</p>	<p>+48 (0) 22 / 7397080 +48 (0) 22 / 7397081</p> <p>+48 (0) 22 / 7397082</p>
<p><b>In USA, Kanada</b></p> <p><b>In USA, Canada</b></p>	<p>WEBER Machine (USA), Inc. 40 Johnson Ave 112 Bangor, ME 04401 USA</p> <p>E-mail: usa@webermt.com</p>	<p>Telefon / phone:</p> <p>Telefax / fax:</p>	<p>+1 (0) 207 / 9474990</p> <p>+1 (0) 207 / 9475452</p>
<p><b>In Südamerika</b></p> <p><b>In South America</b></p>	<p>WEBER Maschinentchnik do Brasil Ltda. Rua Sete de Setembro, 275 93332-470 Novo Hamburgo, RS Brasil</p> <p>E-mail: webermt@webermt.com.br</p>	<p>Telefon / phone:</p> <p>Telefax / fax:</p>	<p>+55 (0) 51 / 5873044</p> <p>+55 (0) 51 / 5872271</p>

<http://www.webermt.com>

