

CF 2

0100211 - 0100214



Spare parts
Spares
Pièces de rechange
Piezas de recambio
Ricambi
Peças de reposição
Pieșe de schimb
Náhradných dielov
Reservele
Części zamienne



Weber Maschinentechnik GmbH
D- 57334 Bad Laasphe / Germany
Tel. +49 (0) 2754 / 398-0
Fax. +49 (0)2754 / 398-101
E-Mail: info@webermt.de
www.webermt.com

BITTE, NOTIEREN SIE SERIENNUMMER UND MOTORNUMMER IHRER MASCHINE:

PLEASE WRITE DOWN SERIALNUMBERS OF MACHINE AND ENGINE:

NOTEZ SVP LE NUMERO DE SERIE ET LE NUMERO DU MOTEUR DE VOTRE MACHINE:

SI PREGA DI ANNOTARE SEMPRE I NUMERI DI SERIE SIA DELLA VS. MACCHINA CHE DEL MOTORE:

MAQUINA: ROGAMOS ANOTEN EL NUMERO DE SERIE Y NUMERO DE MOTOR DE SU MAQUINA:

PROSIMY ZANOTOWAĆ NUMER MASZYNY I SILNIKA

MASCHINE
MACHINE
MACCHINA
MAQUINA
MASZYNA



MOTOR
ENGINE
MOTEUR
MOTORE
SILNIK



ZUR VERMEIDUNG VON FEHLLIEFERUNGEN UND VERZÖGERUNGEN SIND BEI DER BESTELLUNG VON ERSATZTEILEN FOLGENDE ANGABEN UNBEDINGT ERFORDERLICH:

- MASCHINENTYP
- SERIENNUMMER DER MASCHINE
- SERIENNUMMER DES MOTORS (BEI MOTORTEILEN)
- TEILENUMMER
- BESTELLMENGE

TO AVOID ERRORS IN DELIVERY PLEASE STATE THESE PARTICULARS WHEN ORDERING:

- TYPE OF MACHINE
- SERIAL NO. OF MACHINE
- SERIAL NO. OF ENGINE (ON ENGINE PARTS)
- PART-NO.
- QUANTITY REQUIRED

AFIN D'EVITER DES ERREURS DE COMMANDE ET DES RETARDS DE LIVRAISON IL EST NECESSAIRE D'INDIQUER LES CARACTERISTIQUES SUIVANTES:

- TYPE DE MACHINE
- LE NUMERO DE SERIE DE LA MACHINE
- LE NUMERO DE SERIE DU MOTEUR
- LE NUMERO D'IDENTITE DE LA PIECE
- LA QUANTITE SOUHAITEE

ONDE EVITARE DISGUIDI E RITARDI NELLE CONSEGNE DIE RICAMBI SI PREGA DI INDICARE SEMPRE:

- TIPO DELLA MACCHINA
- NUMERO DI SERIE DELLA MACCHINA
- NUMERO DI SERIE DEL MOTORE (SE SI RICHIEDONO PEZZI DEL MOTORE)
- NUMERO D'ORDINE DIE SINGOLI RICAMBI
- QUANTITA

A FI DE EVITAR ERRORES DE ENTREGA, ROGAMOS INDIQUEN LOS SIGUIENTES DATOS CUANDO PASE PEDIDOS DE RECAMBIOS:

- MODELO DE MAQUINA
- NO. DE SERIE DE LA MAQUINA
- NO. DE SERIE DEL MOTOR (EN PIEZAS PARA MOTOR)
- REFERENCIA DEL RECAMBIO
- CANTIDAD PEDIDA

PROSIMY O PODANIE NASTĘPUJĄCYCH DANYCH PRZY SKŁADANIU ZAMÓWIENIA.

- TYP MASZYNY
- NUMER SERYJNY MASZYNY
- NUMER SERYJNY SILNIKA (PRZY CZĘŚCIACH DO SILNIKA)
- NUMER CZĘŚCI ZAMIEWNNEJ
- ZAMAWIANA ILOŚĆ

E 3341-0713

Position Ref.No. Repère Posizione Posición	Menge Quantity Quantité Cantidad	Teile-Nr. Part-No. No. Référence Nr. d'Ordine No. Referenzia	Hinweis Hints Indications Indicazione Indicaciones	Position Ref. No. Repère Posizione Posición	Menge Quantity Quantité Cantidad	Teile-Nr. Part-No. No. Référence Nr. d'Ordine No. Referenzia	Hinweis Hints Indications Indicazione Indicaciones
1	1	11001508		31	1	21000641	DIN7991-M8x25-ISR
2	4	21000579		32	1	25005003	DIN6798-V8,4
3	4	11000985					
4	4	20029022	SKB 10				
5	4	25031004	DIN934-M10				
6	1	25030002	DIN908-M14x1,5				
7	2	25038018	DIN933-M12x20				
8	2	20029032	SKM 12				
9	1	10005404					
10	1	20013008					
11	4	25044004	DIN912-M8x16-10.9				
12	4	20029011	VSKZ 8				
13	1	11000756					
14	1	20013090					
15	1	11000772					
16	2	25038008	DIN933-M8x25				
17	2	20029003	VSK 8				
18	1	11000757					
19	2	25001127					
20							
21							
22							
23	1	25017007					
24	1	11000758					
25	1	10016071					
26	1	10007370					
27	1	20029001	VSK 10				
28	1	11000759					
29	2	25044104	DIN912-M12x40				
30	2	20029026					

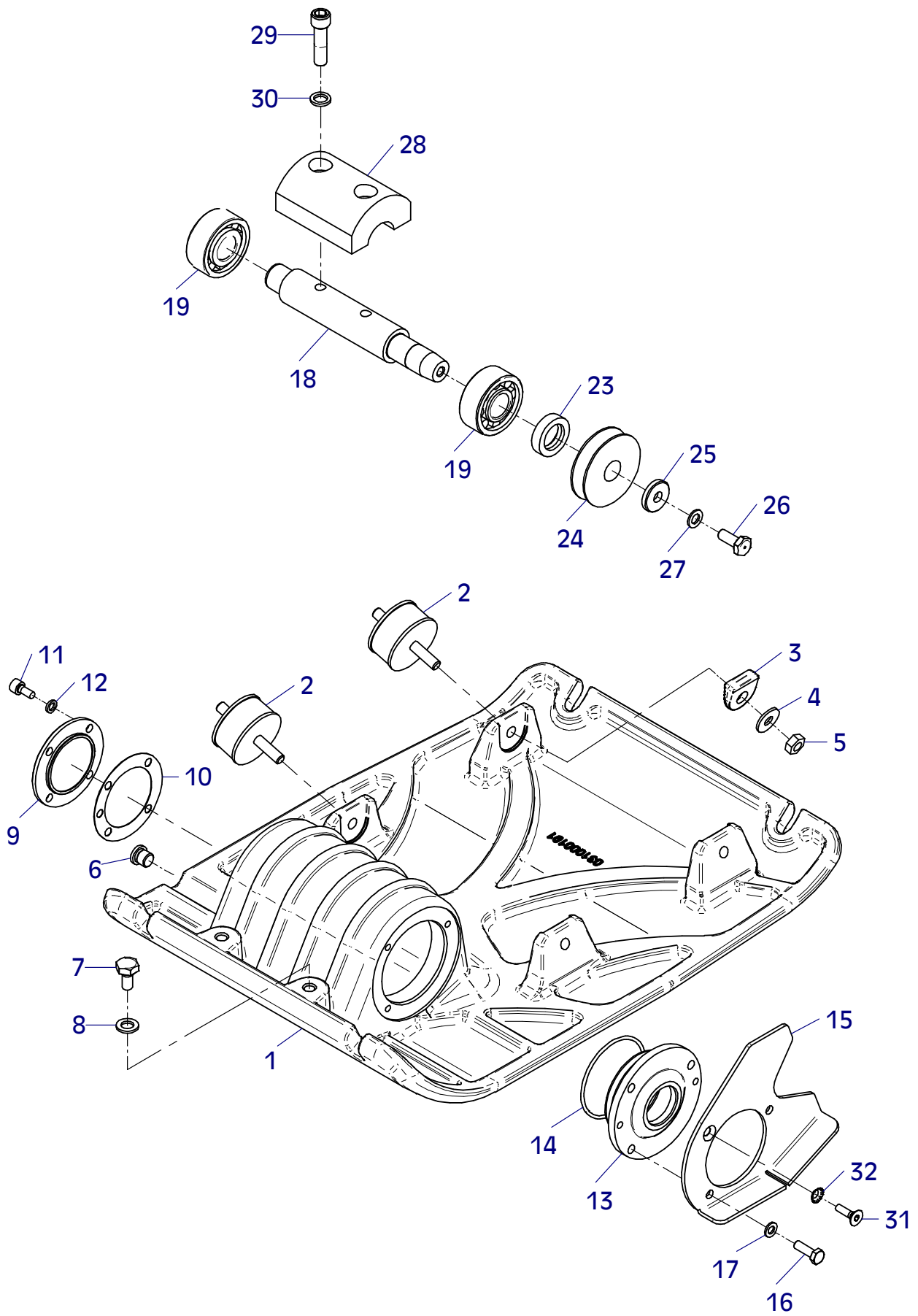

E 3341-0713

E 3342-1210

Position Ref.No. Repère Posizione Posicion	Menge Quantity Quantité Quantità Cantidad	Teile-Nr. Part-No. No. Référence Nr. d'Ordine No. Referenzia	Hinweis Hints Indications Indicazione Indicaciones	Position Ref. No. Repère Posizione Posicion	Menge Quantity Quantité Quantità Cantidad	Teile-Nr. Part-No. No. Référence Nr. d'Ordine No. Referenzia	Hinweis Hints Indications Indicazione Indicaciones
1	1	11000715					
2	4	25049020	DIN7349-10,5				
3	4	20029001	VSK 10				
4	4	25031004	DIN934-M10				
5	1	11000714					
6	4	21000586	DIN7964-M8x50				
7	4	20029003	VSK 8				
8	4	25048002	DIN125-A8,4				
9	1	20026465					
10	2	25025191	DIN80705-M20x1,5				
11	2	20005021					
12	2	20022002	Tensilock M8				
13	1	11001109					
14	1	25031019	DIN936-M12				

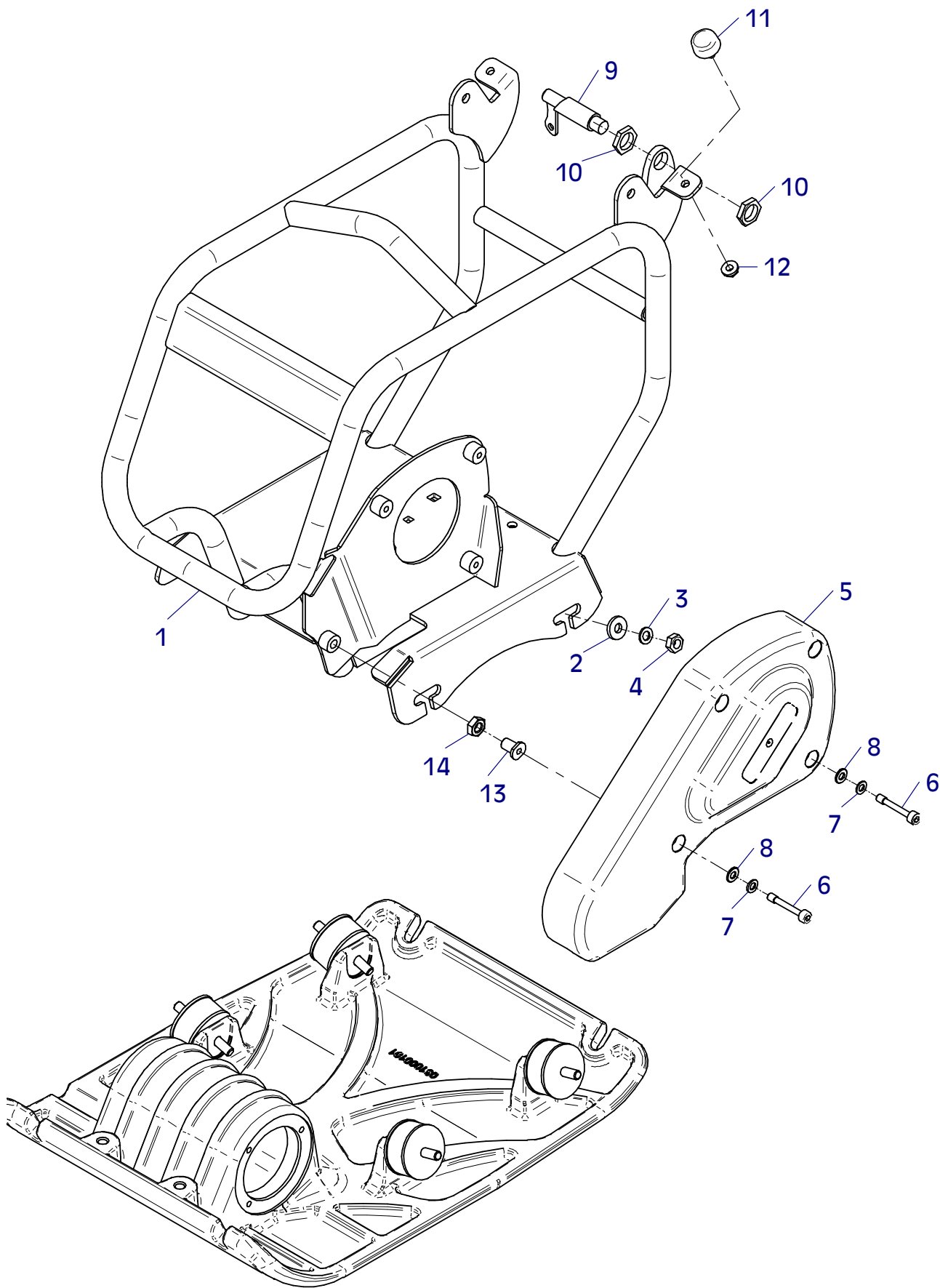

E 3342-1210

E 3343-1014

Position Ref.No. Repère Posizione Posicion	Menge Quantity Quantité Quantita Cantidad	Teile-Nr. Part-No. No. Référence Nr. d'Ordine No. Referenzia	Hinweis Hints Indications Indicazione Indicaciones	Position Ref. No. Repère Posizione Posicion	Menge Quantity Quantité Quantita Cantidad	Teile-Nr. Part-No. No. Référence Nr. d'Ordine No. Referenzia	Hinweis Hints Indications Indicazione Indicaciones
1	1	21000080					
2	2	11001025					
3	4	25040028	DIN931-M8x45				
4	4	25049026	DIN7349-8,4				
5	4	20029024					
6	4	25031003	DIN934-M8				
7	1	21000500					
8	1	21000634					
9	1	25040065	DIN931-M8x40				
10	1	20029021	SKB 8				
11	4	25048002	DIN125-A8,4				

Robin

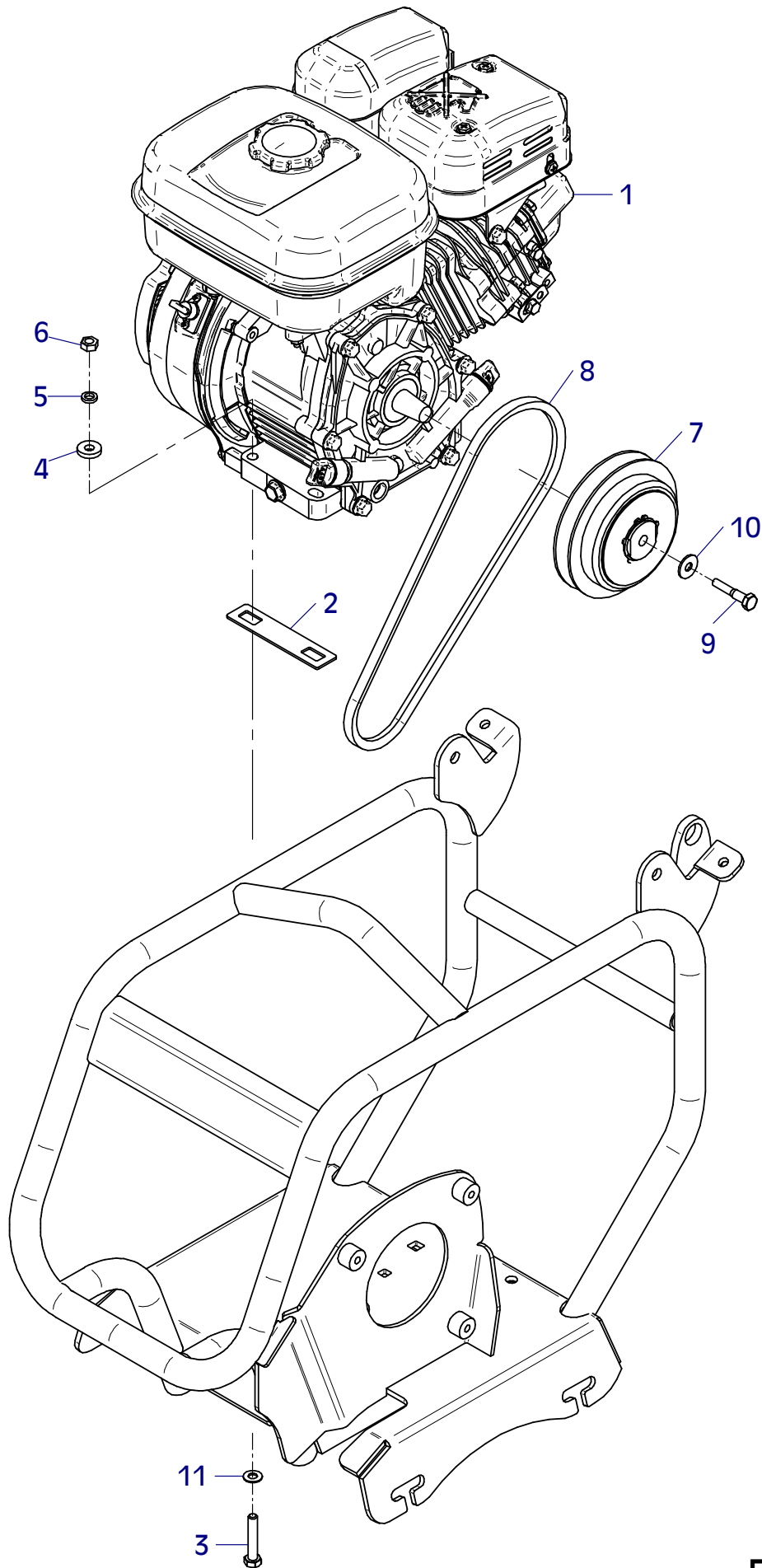

E 3343-1014

E 3350-0310

Position Ref.No. Repère Posizione Posicion	Menge Quantity Quantité Quantita Cantidad	Teile-Nr. Part-No. No. Référence Nr. d'Ordine No. Referenzia	Hinweis Hints Indications Indicazione Indicaciones	Position Ref. No. Repère Posizione Posicion	Menge Quantity Quantité Quantita Cantidad	Teile-Nr. Part-No. No. Référence Nr. d'Ordine No. Referenzia	Hinweis Hints Indications Indicazione Indicaciones
1	1	21000500					
2	2	20002285					
3	2	21000594					
4	2	20002223					

Robin

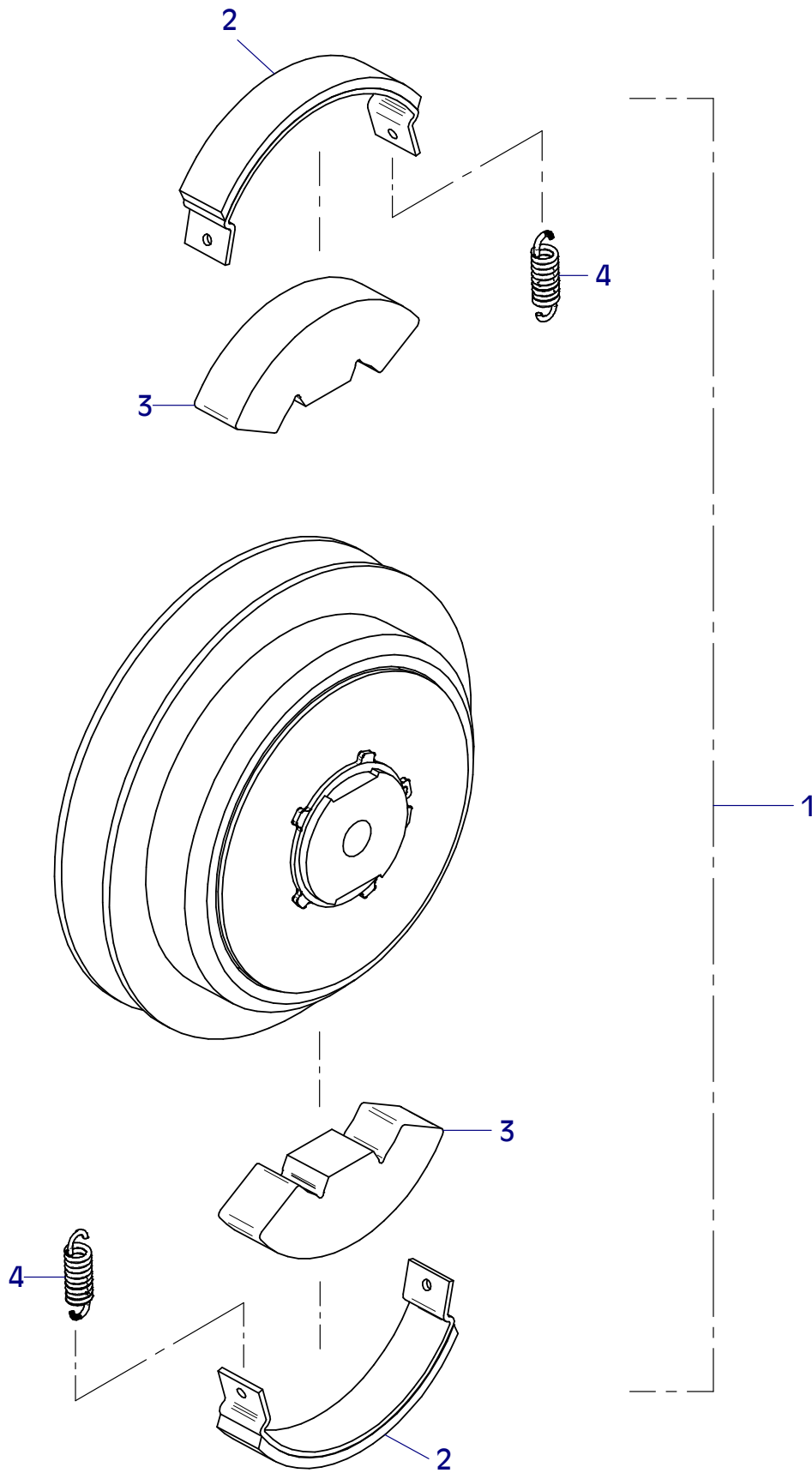

E 3350-0310

E 3344-1014

Position Ref.No. Repère Posizione Posicion	Menge Quantity Quantité Quantita Cantidad	Teile-Nr. Part-No. No. Référence Nr. d'Ordine No. Referenzia	Hinweis Hints Indications Indicazione Indicaciones	Position Ref. No. Repère Posizione Posicion	Menge Quantity Quantité Quantita Cantidad	Teile-Nr. Part-No. No. Référence Nr. d'Ordine No. Referenzia	Hinweis Hints Indications Indicazione Indicaciones
1	1	21000608					
2	2	11001025					
3	4	25040028	DIN931-M8x45				
4	4	25049026	DIN7349-8,4				
5	4	20029024					
6	4	25031003	DIN934-M8				
7	1	21000501					
8	1	10016088					
9	1	10005238					
10	1	21000634					
11	1	25043005	DIN933-5/16"				
12	1	20029021	SKB 8				
13	4	25048002	DIN125-A8,4				
14							
15							
16	1	21000610					
17	2	20026389					

Honda

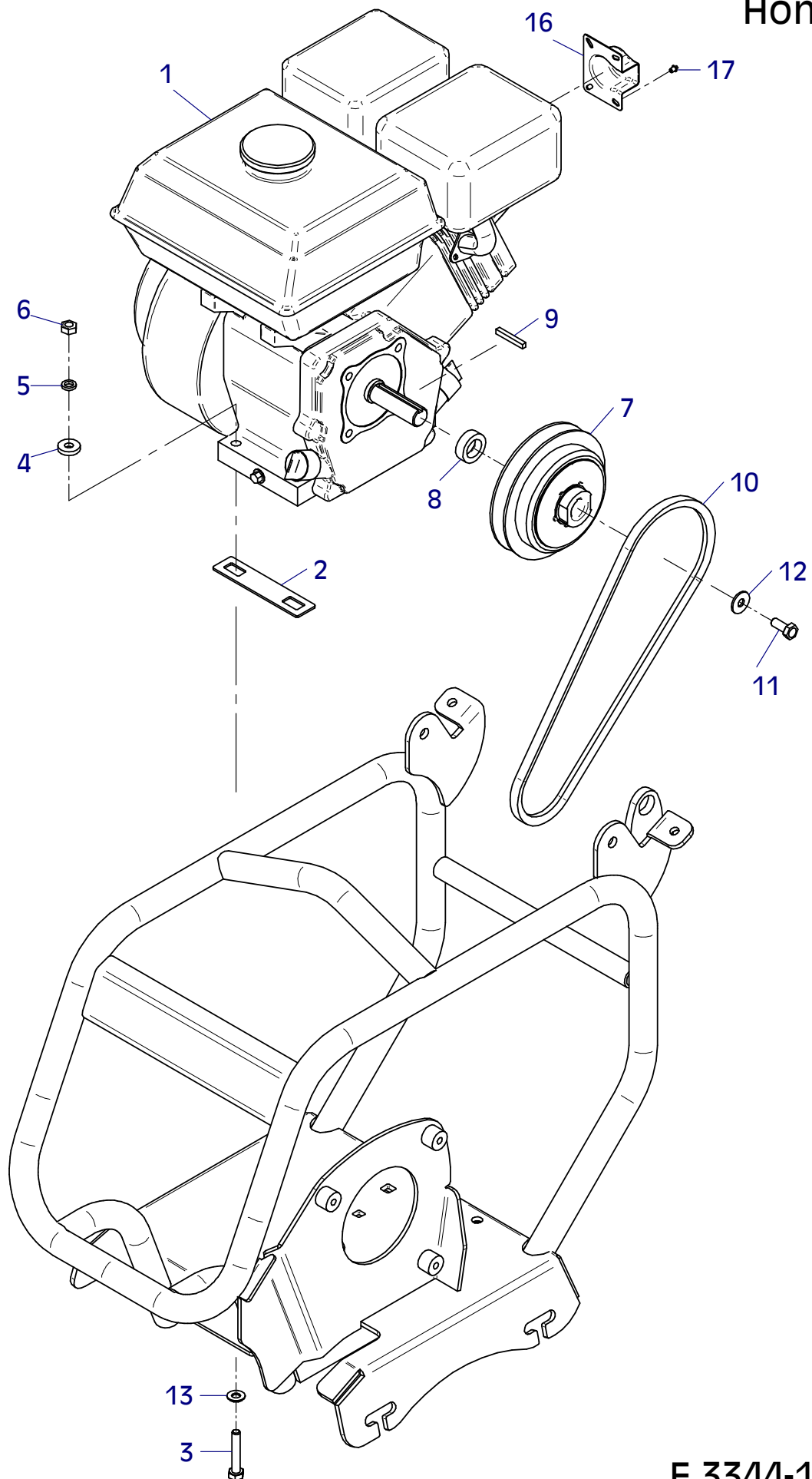

E 3344-1014

E 3351-0310

Position Ref.No. Repère Posizione Posicion	Menge Quantity Quantité Quantita Cantidad	Teile-Nr. Part-No. No. Référence Nr. d'Ordine No. Referenzia	Hinweis Hints Indications Indicazione Indicaciones	Position Ref. No. Repère Posizione Posicion	Menge Quantity Quantité Quantita Cantidad	Teile-Nr. Part-No. No. Référence Nr. d'Ordine No. Referenzia	Hinweis Hints Indications Indicazione Indicaciones
1	1	21000501					
2	2	20002285					
3	2	21000594					
4	2	20002223					

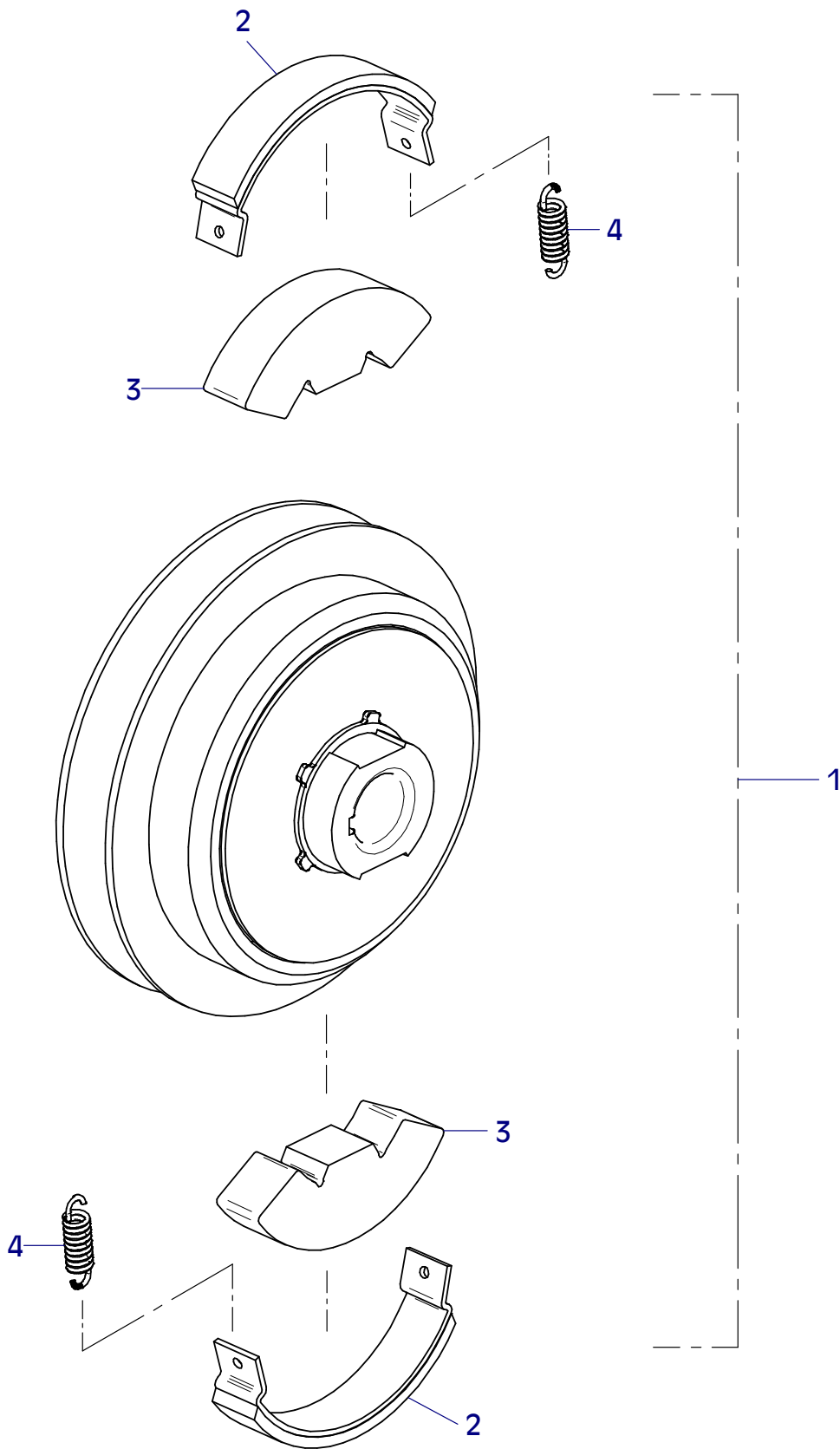

E 3345-0811

Position Ref.No. Repère Posizione Posicion	Menge Quantity Quantité Quantita Cantidad	Teile-Nr. Part-No. No. Référence Nr. d'Ordine No. Referenzia	Hinweis Hints Indications Indicazione Indicaciones	Position Ref. No. Repère Posizione Posicion	Menge Quantity Quantité Quantita Cantidad	Teile-Nr. Part-No. No. Référence Nr. d'Ordine No. Referenzia	Hinweis Hints Indications Indicazione Indicaciones
1	1	11000751					
2	2	20025015					
3	1	25040012	DIN931-M10x55				
4	2	20029001	VSK 10				
5	2	25049013	DIN440-R11,5				
6	2	25031028	DIN1587-M10				
7	2	11000790					
8	1	11000754					
9	7	25044110	DIN912-M6x40				
10	7	25031012	DIN985-M6				
11	2	11001006					
12	2	11001007					
13	2	20029003	VSK 8				
14	2	25038009	DIN933-M8x30				
15	1	21000661					
16	1	25049011	DIN7349-13x30x6				
17	1	25048003	DIN125-A10,5				
18	2	10015958					

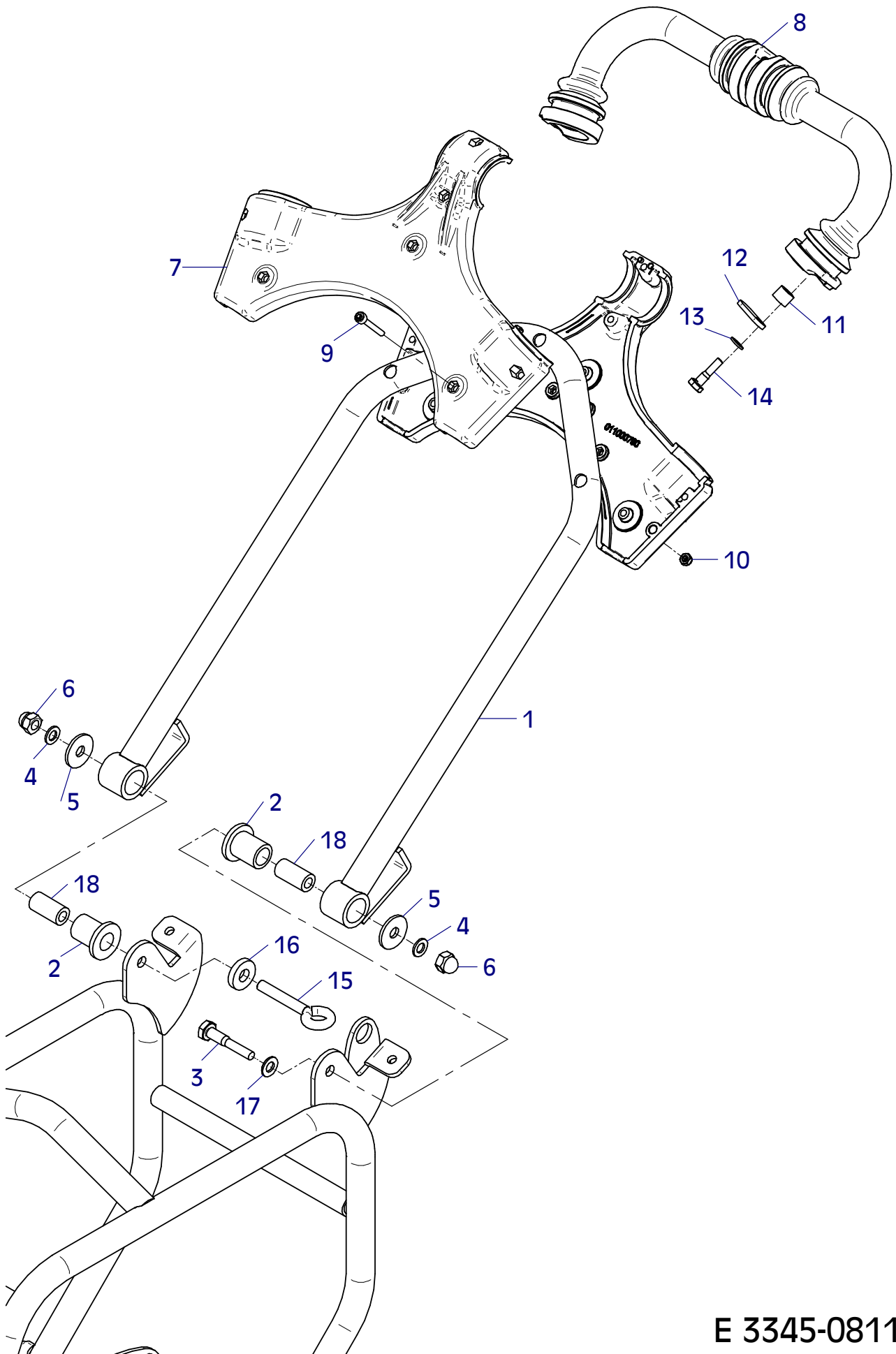

E 3345-0811

E 3409-1210

Position Ref.No. Repère Posizione Posicion	Menge Quantity Quantité Quantita Cantidad	Teile-Nr. Part-No. No. Référence Nr. d'Ordine No. Referenzia	Hinweis Hints Indications Indicazione Indicaciones	Position Ref. No. Repère Posizione Posicion	Menge Quantity Quantité Quantita Cantidad	Teile-Nr. Part-No. No. Référence Nr. d'Ordine No. Referenzia	Hinweis Hints Indications Indicazione Indicaciones
1	2	25047016	DIN7991-M5x16				
2	2	25031023	DIN985-M5				
3	2	21000682					
10	1	21000582	Honda				
11	1	20026383					
12	1	21000335					
20	1	21000582	Robin				
21	1	25031002	DIN934-M6				
22	1	21000239					

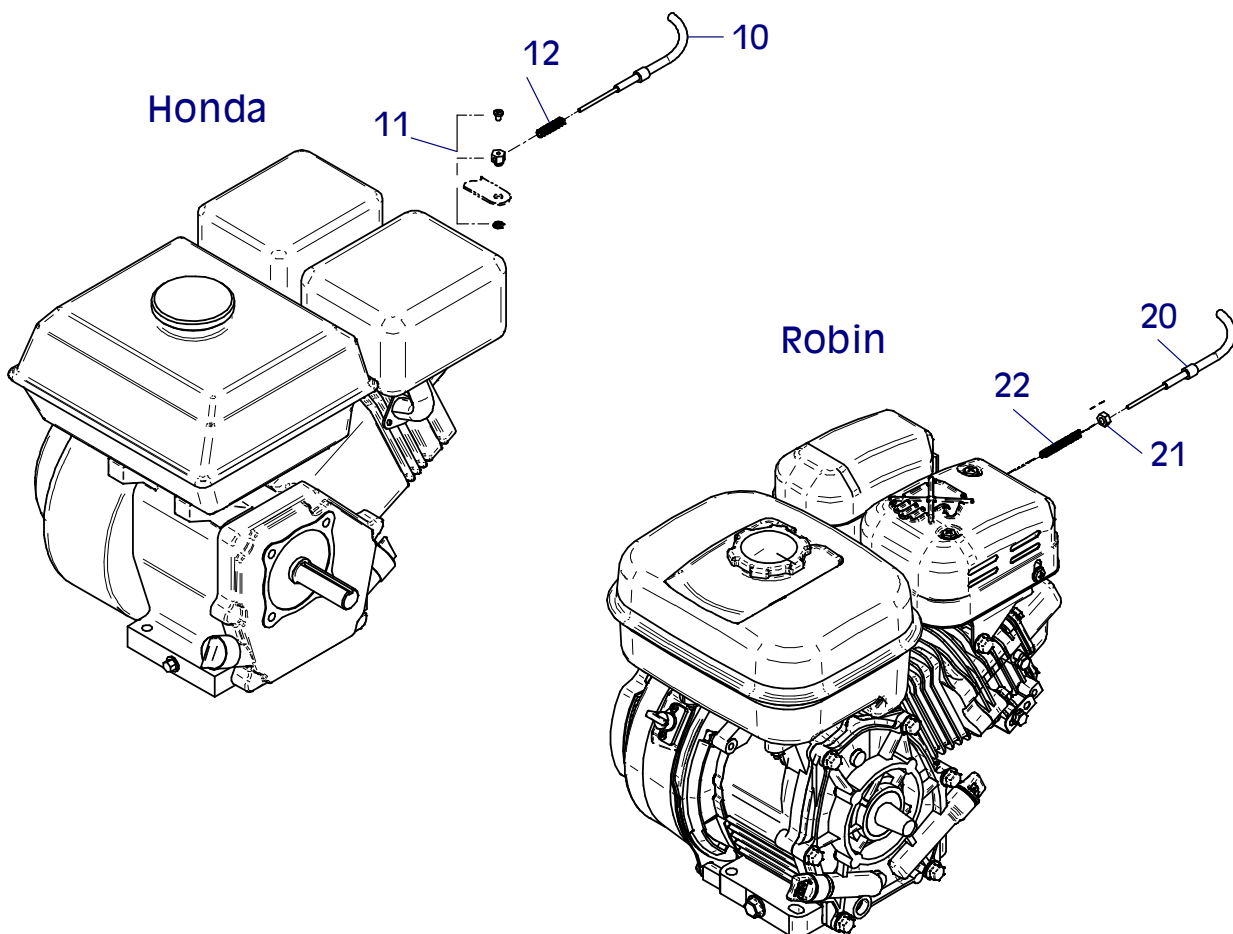
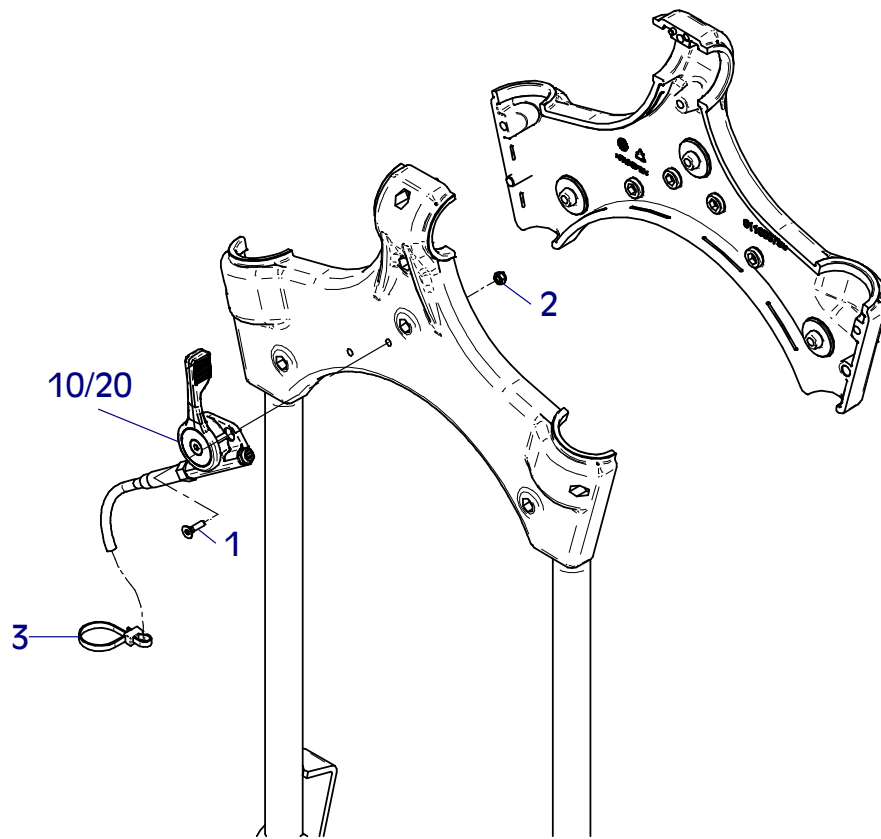

E 3409-1210

E 3532-0514

Position Ref.No. Repère Posizione Posicion	Menge Quantity Quantité Quantita Cantidad	Teile-Nr. Part-No. No. Référence Nr. d'Ordine No. Referenzia	Hinweis Hints Indications Indicazione Indicaciones	Position Ref. No. Repère Posizione Posicion	Menge Quantity Quantité Quantita Cantidad	Teile-Nr. Part-No. No. Référence Nr. d'Ordine No. Referenzia	Hinweis Hints Indications Indicazione Indicaciones
1	1	21000481					
2	1	20025719					
3	1	11001311					
4	1	11001598	CF 2				
4	1	11001599	CF 3				
5	2	25030002	DIN908-M14x1,5				
6	1	11001597					
7	2	11001063					
8	1	21000492	DIN7991-M6x35				
9	1	25005002	DIN6798-V6,4				
10	1	21000849	0,3 m				
11	1	20007054					
12	1	11000775					
13	1	11000777					
14	4	25047020	DIN7991-M6x16				
15	4	25005002	DIN6798-V6,4				
16	1	11000786					
17	1	21000495					
18	1	25031019	DIN936-M12				
19	1	21000631	DIN6799-9,0				
20	1	25048004	DIN125-A13				
21	1	21000494					
22	1	25038017	DIN933-M10x40				
23	1	20029001	VSK 10				
24	1	25031004	DIN934-M10				

E 3355-1110

Position Ref.No. Repère Posizione Posicion	Menge Quantity Quantité Quantita Cantidad	Teile-Nr. Part-No. No. Référence Nr. d'Ordine No. Referenzia	Hinweis Hints Indications Indicazione Indicaciones	Position Ref. No. Repère Posizione Posicion	Menge Quantity Quantité Quantita Cantidad	Teile-Nr. Part-No. No. Référence Nr. d'Ordine No. Referenzia	Hinweis Hints Indications Indicazione Indicaciones
1	1	11000762					
2	2	21000645					
3	2	21000869					
4	2	20008088					
5	1	11000768					
6	2	21000497					
7	1	11000769					
8	1	21000670	DIN931-M10x150				
9	1	25048003	DIN125-A10,5				
10	2	25038014	DIN933-M10x25				
11	2	20029001	VSK 10				
12	1	21000491					
13							
14	1	11000767					
15	1	25040011	DIN931-M10x50				
16	2	25048003	DIN125-A10,5				
17	1	20029001	VSK 10				
18	1	25031004	DIN934-M10				
19	1	20029001	VSK 10				
20	1	25031004	DIN934-M10				

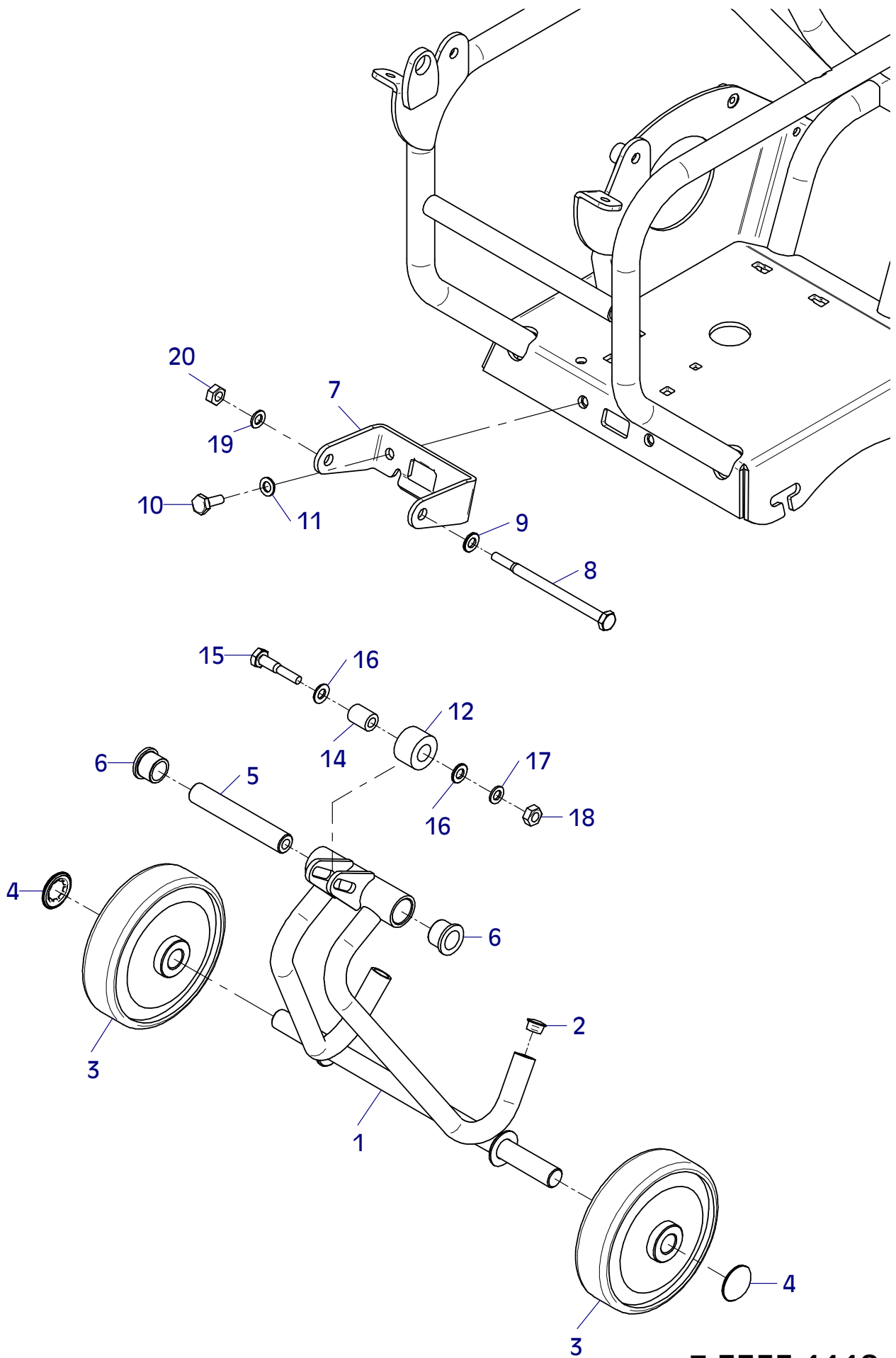

E 3355-1110

E 3356-0512

Position Ref.No. Repère Posizione Posicion	Menge Quantity Quantité Quantita Cantidad	Teile-Nr. Part-No. No. Référence Nr. d'Ordine No. Referenzia	Hinweis Hints Indications Indicazione Indicaciones	Position Ref. No. Repère Posizione Posicion	Menge Quantity Quantité Quantita Cantidad	Teile-Nr. Part-No. No. Référence Nr. d'Ordine No. Referenzia	Hinweis Hints Indications Indicazione Indicaciones
1	1	11000773					
2	1	11000793					
3	2	25040012	DIN931-M10x55				
4	2	25049013	DIN440-R11,5				
5	2	25031014	DIN985-M10				
6	2	11000987					
7	2	11000336					
8	2	25047015	DIN7991-M10x20				

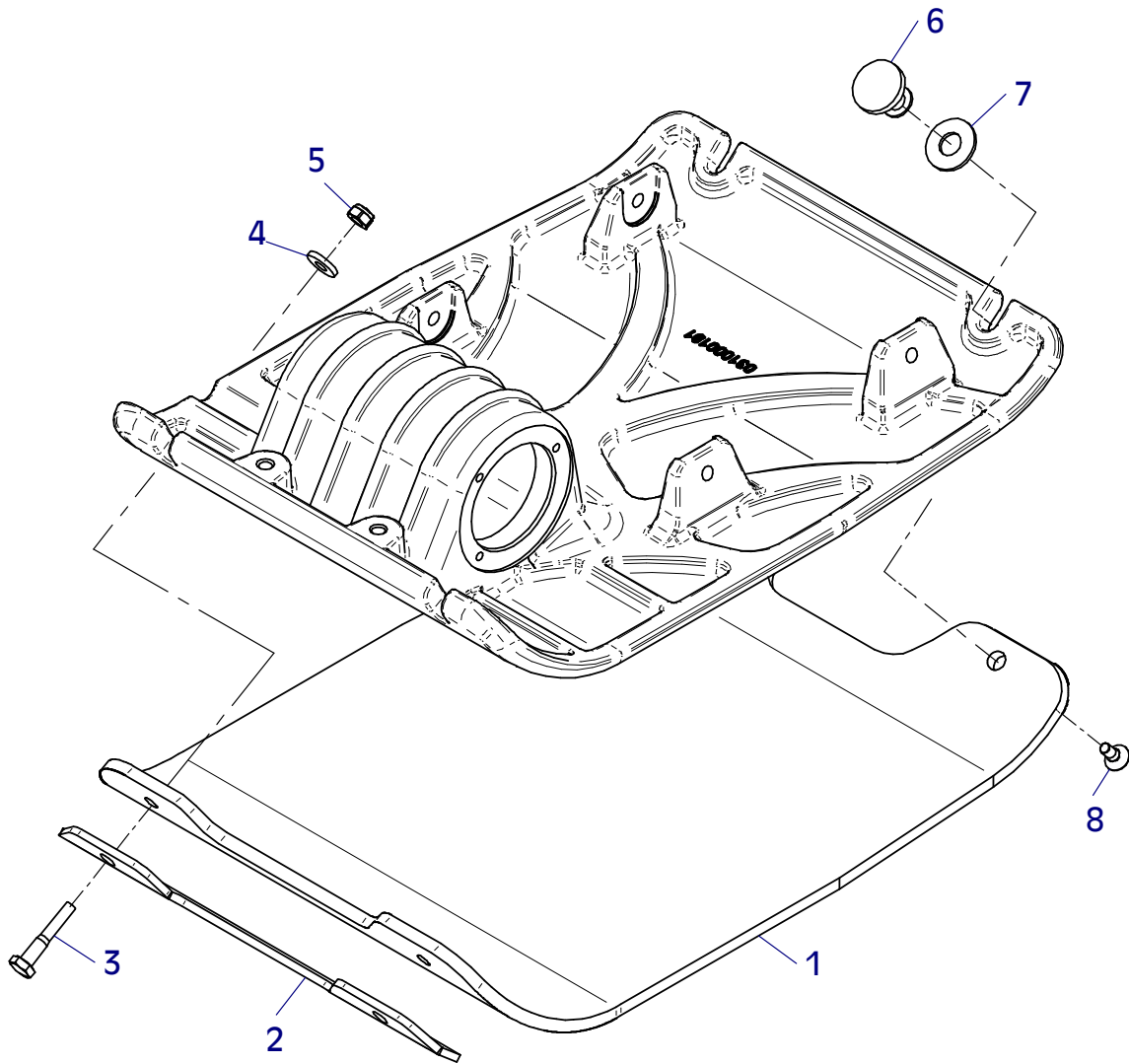

E 3356-0512

E 3575-0614

Position Ref.No. Repère Posizione Posicion	Menge Quantity Quantité Quantita Cantidad	Teile-Nr. Part-No. No. Référence Nr. d'Ordine No. Referenzia	Hinweis Hints Indications Indicazione Indicaciones	Position Ref. No. Repère Posizione Posicion	Menge Quantity Quantité Quantita Cantidad	Teile-Nr. Part-No. No. Référence Nr. d'Ordine No. Referenzia	Hinweis Hints Indications Indicazione Indicaciones
1	1	20019006					
2	1	21000741					
3	1	21000856					
4	1	21000857					
5	1	21000047					
6	1	20019376					
7	1	20019377					
8	1	20019007					
9	1	21000474					
10	1	20019418					
11	1	20019397					
12	1	21000313					
13	1	20019357					
14	1	20019410					
15	1	20019097					
16	1	20019281					
17	1	20019104					
18	1	20019118					
19	1	20019401					
20	1	20019002					
21	1	20019003					
22	1	20019322					

Alle Schraubenverbindungen ständig auf festen Sitz überwachen!
 -Besonders nach dem ersten Einsatz-

Continuously check all screwed connections for firm seating
 -particularly after initial employment-

Controler continuellement tous les raccords a vis pour un siege ferme
 -particulierement apres l'emploi initial-

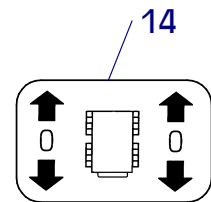
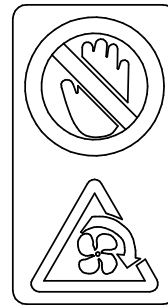
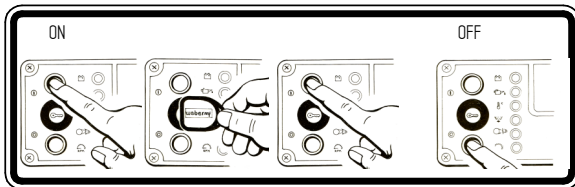
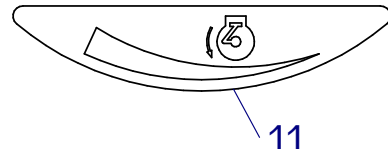
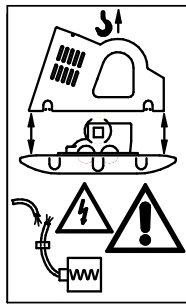
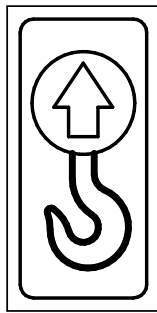
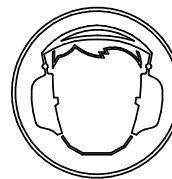
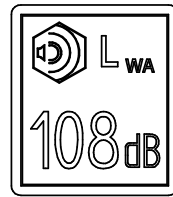
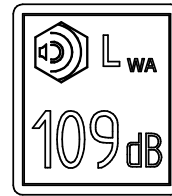
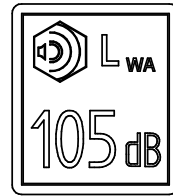
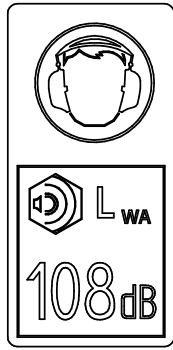
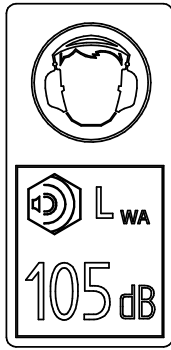
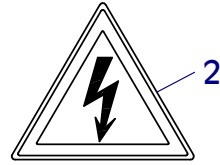

Normalbenzin
Gasoline
Essence

Diesel

Wasser
Water
Eau

HYDRAULIC
OIL

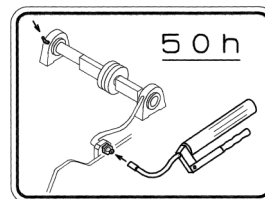
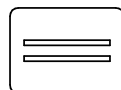
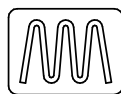
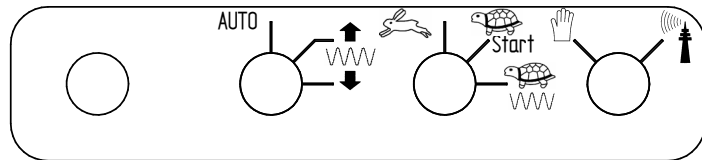

Wenn Sie Fragen, Anregungen, Probleme, usw. haben, wenden Sie sich bitte an eine der unten genannten Adressen:

For problems, questions and further information refer to one of the following addresses:

Si des questions, des suggestions, des problèmes ... survenaient, veuillez vous adresser a l'une des adresses - ci dessous

<p>in Deutschland</p> <p>in Germany</p> <p>Pour l' Allemagne</p>	<p>WEBER Maschinenteknik GmbH 57334 Bad Laasphe – Rückershausen Im Boden 5-8, 10</p>	<p>Telefon Telefax</p> <p>E-Mail</p>	<p>+ 49 (0) 2754 - 398-0 + 49 (0) 2754 - 398101-Zentrale switchboard Central + 49 (0) 2754 - 398102-Ersatzteil-Direktlinie spare parts-directlinie Ligne direct pièces détachées</p> <p>g.voelkel@webermt.de</p>
<p>in Frankreich</p> <p>in France</p> <p>Pour la France</p>	<p>WEBER Technologie SARL 26' rue d' Arsonval 69680 Chassieu</p>	<p>Telefon Telefax</p> <p>E-Mail</p>	<p>+ 33 (0) 472 - 791020 + 33 (0) 472 - 791021</p> <p>france@webermt.com</p>
<p>in Polen</p> <p>in Poland</p> <p>Pour la Pologne</p>	<p>WEBER Maschinenteknik Sp. zo.o. Ul. Grodziska 7 05-830 Stara Wies</p>	<p>Telefon Telefax</p> <p>E-Mail</p>	<p>+ 48 (0) 22 - 739 70 - 80 + 48 (0) 22 - 739 70 - 81 + 48 (0) 22 - 739 70 - 82</p> <p>info@webermt.com.pl</p>
<p>in Tschechien</p> <p>in Czechia</p> <p>Pour la Tchéquie</p>	<p>WEBER MT s.r.o. V Piskovně 2054 278 01 Kralupy nad Vitavou</p>	<p>Telefon</p> <p>E-Mail</p>	<p>+ 42 (0) 776 222 216 + 42 (0) 776 222 261</p> <p>info@webermt.cz</p>
<p>in USA und Kanada</p> <p>in USA and Canada</p> <p>Pour les Etats Unis Et le Canada</p>	<p>WEBER MT, Inc. 45 Dowd Road Bangor, ME 04401</p>	<p>Telefon Telefax</p> <p>E-Mail</p>	<p>+ 1(207) - 947 - 4990 + 1(207) - 947 - 5452</p> <p>sales@webermt.com service@webermt.com</p>
<p>in Süd – Amerika</p> <p>in South – America</p> <p>Pour l' Amérique du sud</p>	<p>WEBER Maschinenteknik do Brasil Máquinas Para Construção Ltda. Rua Curt Wacker, nº 45 93332 – 200 Novo Hamburgo, RS Brasil</p>	<p>Telefon Telefax</p> <p>E-Mail</p>	<p>+ 55 (0) 51- 587 3044 + 55 (0) 51- 587 2271</p> <p>webermt@webermt.com.br</p>

