

CF 1

0100111 - 0100115



Spare parts
Spares
Pièces de rechange
Piezas de recambio
Ricambi
Peças de reposição
Piese de schimb
Náhradných dielov
Reservele
Części zamienne



Weber Maschinenteknik GmbH
D- 57334 Bad Laasphe / Germany
Tel. +49 (0) 2754 / 398-0
Fax. +49 (0)2754 / 398-101
E-Mail: info@webermt.de
www.webermt.com

BITTE, NOTIEREN SIE SERIENNUMMER UND MOTORNUMMER IHRER MASCHINE:

PLEASE WRITE DOWN SERIALNUMBERS OF MACHINE AND ENGINE:

NOTEZ SVP LE NUMERO DE SERIE ET LE NUMERO DU MOTEUR DE VOTRE MACHINE:

SI PREGA DI ANNOTARE SEMPRE I NUMERI DI SERIE SIA DELLA VS. MACCHINA CHE DEL MOTORE:

MAQUINA: ROGAMOS ANOTEN EL NUMERO DE SERIE Y NUMERO DE MOTOR DE SU MAQUINA:

PROSIMY ZANOTOWAĆ NUMER MASZYNY I SILNIKA

MASCHINE
MACHINE
MACCHINA
MAQUINA
MASZYNA



MOTOR
ENGINE
MOTEUR
MOTORE
SILNIK



ZUR VERMEIDUNG VON FEHLLIEFERUNGEN UND VERZÖGERUNGEN SIND BEI DER BESTELLUNG VON ERSATZTEILEN FOLGENDE ANGABEN UNBEDINGT ERFORDERLICH:

- MASCHINENTYP
- SERIENNUMMER DER MASCHINE
- SERIENNUMMER DES MOTORS (BEI MOTORTEILEN)
- TEILENUMMER
- BESTELLMENGE

TO AVOID ERRORS IN DELIVERY PLEASE STATE THESE PARTICULARS WHEN ORDERING:

- TYPE OF MACHINE
- SERIAL NO. OF MACHINE
- SERIAL NO. OF ENGINE (ON ENGINE PARTS)
- PART-NO.
- QUANTITY REQUIRED

AFIN D'EVITER DES ERREURS DE COMMANDE ET DES RETARDS DE LIVRAISON IL EST NECESSAIRE D'INDIQUER LES CARACTERISTIQUES SUIVANTES:

- TYPE DE MACHINE
- LE NUMERO DE SERIE DE LA MACHINE
- LE NUMERO DE SERIE DU MOTEUR
- LE NUMERO D'IDENTITE DE LA PIECE
- LA QUANTITE SOUHAITEE

ONDE EVITARE DISGUIDI E RITARDI NELLE CONSEGNE DIE RICAMBI SI PREGA DI INDICARE SEMPRE:

- TIPO DELLA MACCHINA
- NUMERO DI SERIE DELLA MACCHINA
- NUMERO DI SERIE DEL MOTORE (SE SI RICHIEDONO PEZZI DEL MOTORE)
- NUMERO D'ORDINE DIE SINGOLI RICAMBI
- QUANTITA

A FI DE EVITAR ERRORES DE ENTREGA, ROGAMOS INDIQUEN LOS SIGUIENTES DATOS CUANDO PASE PEDIDOS DE RECAMBIOS:

- MODELO DE MAQUINA
- NO. DE SERIE DE LA MAQUINA
- NO. DE SERIE DEL MOTOR (EN PIEZAS PARA MOTOR)
- REFERENCIA DEL RECAMBIO
- CANTIDAD PEDIDA

PROSIMY O PODANIE NASTĘPUJĄCYCH DANYCH PRZY SKŁADANIU ZAMÓWIENIA.

- TYP MASZYNY
- NUMER SERYJNY MASZYNY
- NUMER SERYJNY SILNIKA (PRZY CZĘŚCIACH DO SILNIKA)
- NUMER CZĘŚCI ZAMIEWNEJ
- ZAMAWIANA ILOŚĆ

E 3401-0811

Position Ref.No. Repère Posizione Posicion	Menge Quantity Quantité Cantidad	Teile-Nr. Part-No. No. Référence Nr. d'Ordine No. Referenzia	Hinweis Hints Indications Indicazione Indicaciones	Position Ref. No. Repère Posizione Posicion	Menge Quantity Quantité Cantidad	Teile-Nr. Part-No. No. Référence Nr. d'Ordine No. Referenzia	Hinweis Hints Indications Indicazione Indicaciones
1	1	11000930		31	2	25044026	DIN912-M12x35
2	4	20004039		32	2	20029026	
3	4	20022003	Tensilock M10				
4							
5	1	25030002	DIN908-M14x1,5				
6	1	11000789					
7	2	11001031					
8	1	10005404					
9	1	20013008					
10	4	25044004	DIN912-M8x16-10.9				
11	4	20029011	VSKZ 8				
12	1	11000756					
13	1	20013090					
14	1	11000934					
15	2	25044006	DIN912-M8x25				
16	2	20029011	VSKZ 8				
17	1	21000641	DIN7991-M8x25-ISR				
18	1	25005003	DIN6798-V8,4				
19	1	11000945					
20	2	25001152					
21	0	25025218	DIN988-PS-50x62x0,5				
22	0	25025217	DIN988-PS-50x62x0,2				
23	0	25025215	DIN988-PS-50x62x0,1				
24	1	25017007					
25	1	11000970					
26	1	11000971					
27	1	10016071					
28	1	10007370					
29	1	20029001	VSK 10				
30	1	11000946					

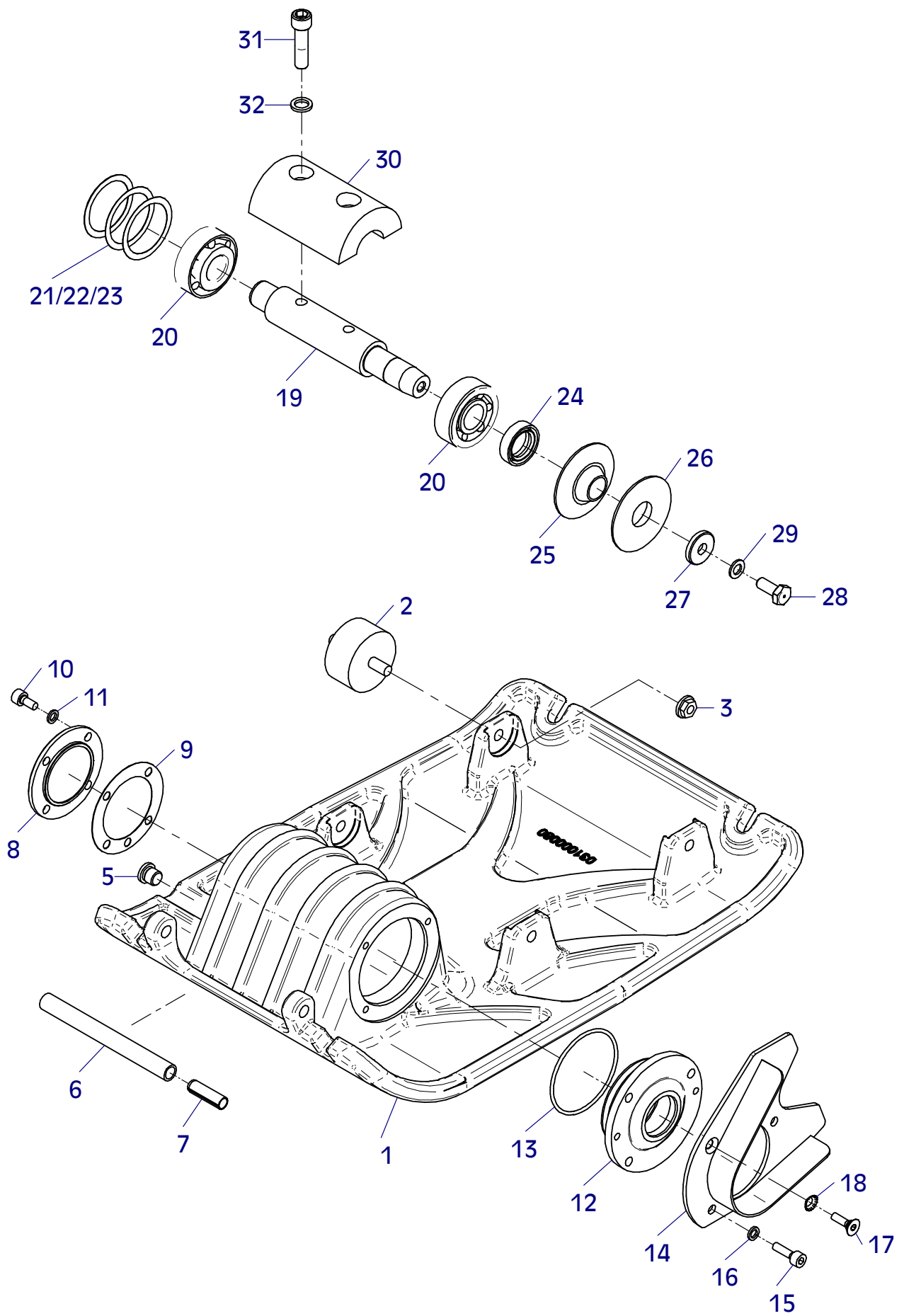

E 3401-0811

E 3402-0911

Position Ref.No. Repère Posizione Posicion	Menge Quantity Quantité Quantita Cantidad	Teile-Nr. Part-No. No. Référence Nr. d'Ordine No. Referenzia	Hinweis Hints Indications Indicazione Indicaciones	Position Ref. No. Repère Posizione Posicion	Menge Quantity Quantité Quantita Cantidad	Teile-Nr. Part-No. No. Référence Nr. d'Ordine No. Referenzia	Hinweis Hints Indications Indicazione Indicaciones
1	1	11000937					
2	4	20029022	SKB 10				
3	4	25031028	DIN1587-M10				
4	1	11000714					
5	4	21000586	DIN7964-M8x50				
6	4	20029003	VSK 8				
7	4	25048002	DIN125-A8,4				
8	1	11001184					
9	1	25038007	DIN933-M8x20				
10	2	20029021	SKB 8				
11	1	25031003	DIN934-M8				

E 3403-0911

Position Ref.No. Repère Posizione Posicion	Menge Quantity Quantité Quantita Cantidad	Teile-Nr. Part-No. No. Référence Nr. d'Ordine No. Referenzia	Hinweis Hints Indications Indicazione Indicaciones	Position Ref. No. Repère Posizione Posicion	Menge Quantity Quantité Quantita Cantidad	Teile-Nr. Part-No. No. Référence Nr. d'Ordine No. Referenzia	Hinweis Hints Indications Indicazione Indicaciones
1	1	21000080					
2	2	11001025					
3	4	25025185	DIN603-M8x45				
4	4	25049026	DIN7349-8,4				
5	4	20029024					
6	4	25031003	DIN934-M8				
7	1	11000931					
8	4	25047017	DIN7991-M8x20				
9	4	25005003	DIN6798-V8,4				
10	1	21000500					
11	1	21000634					
12	1	25040065	DIN931-M8x40				
13	1	20029021	SKB 8				

Robin

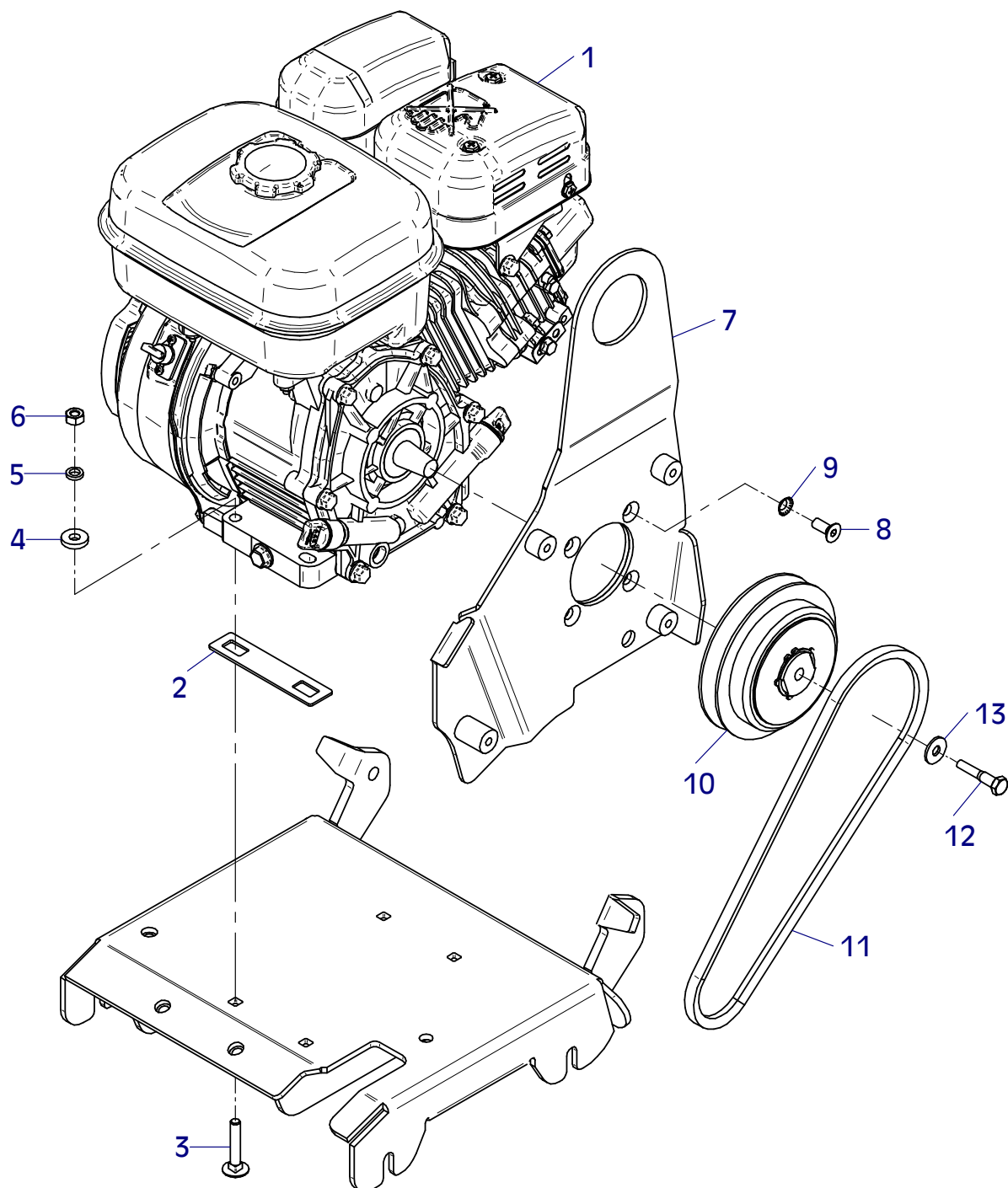

E 3350-0310

Position Ref.No. Repère Posizione Posicion	Menge Quantity Quantité Quantita Cantidad	Teile-Nr. Part-No. No. Référence Nr. d'Ordine No. Referenzia	Hinweis Hints Indications Indicazione Indicaciones	Position Ref. No. Repère Posizione Posicion	Menge Quantity Quantité Quantita Cantidad	Teile-Nr. Part-No. No. Référence Nr. d'Ordine No. Referenzia	Hinweis Hints Indications Indicazione Indicaciones
1	1	21000500					
2	2	20002285					
3	2	21000594					
4	2	20002223					

Robin

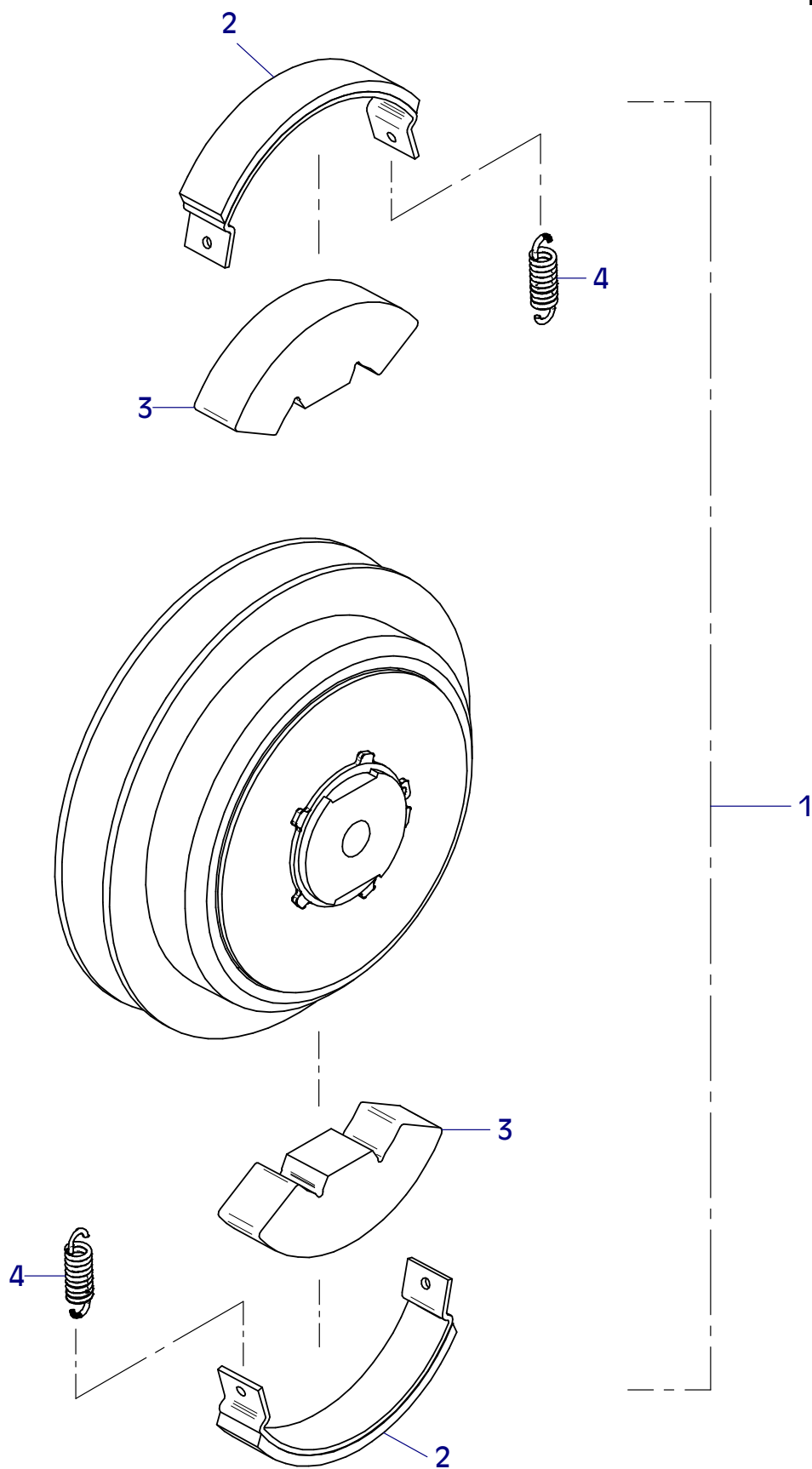

E 3404-0911

Position Ref.No. Repère Posizione Posicion	Menge Quantity Quantité Quantita Cantidad	Teile-Nr. Part-No. No. Référence Nr. d'Ordine No. Referenzia	Hinweis Hints Indications Indicazione Indicaciones	Position Ref. No. Repère Posizione Posicion	Menge Quantity Quantité Quantita Cantidad	Teile-Nr. Part-No. No. Référence Nr. d'Ordine No. Referenzia	Hinweis Hints Indications Indicazione Indicaciones
1	1	21000607					
2	2	11001025					
3	4	25025185	DIN603-M8x45				
4	4	25049026	DIN7349-8,4				
5	4	20029024					
6	4	25031003	DIN934-M8				
7	1	11000931					
8	4	25047062	DIN7991-5/16"-24UNF				
9	4	25005003	DIN6798-V8,4				
10	1	21000501					
11	1	10005238					
12	1	10016088					
13	1	21000634					
14	1	25043005	DIN933-5/16"				
15	1	20029021	SKB 8				
16	1	21000610					
17	4	20026389					

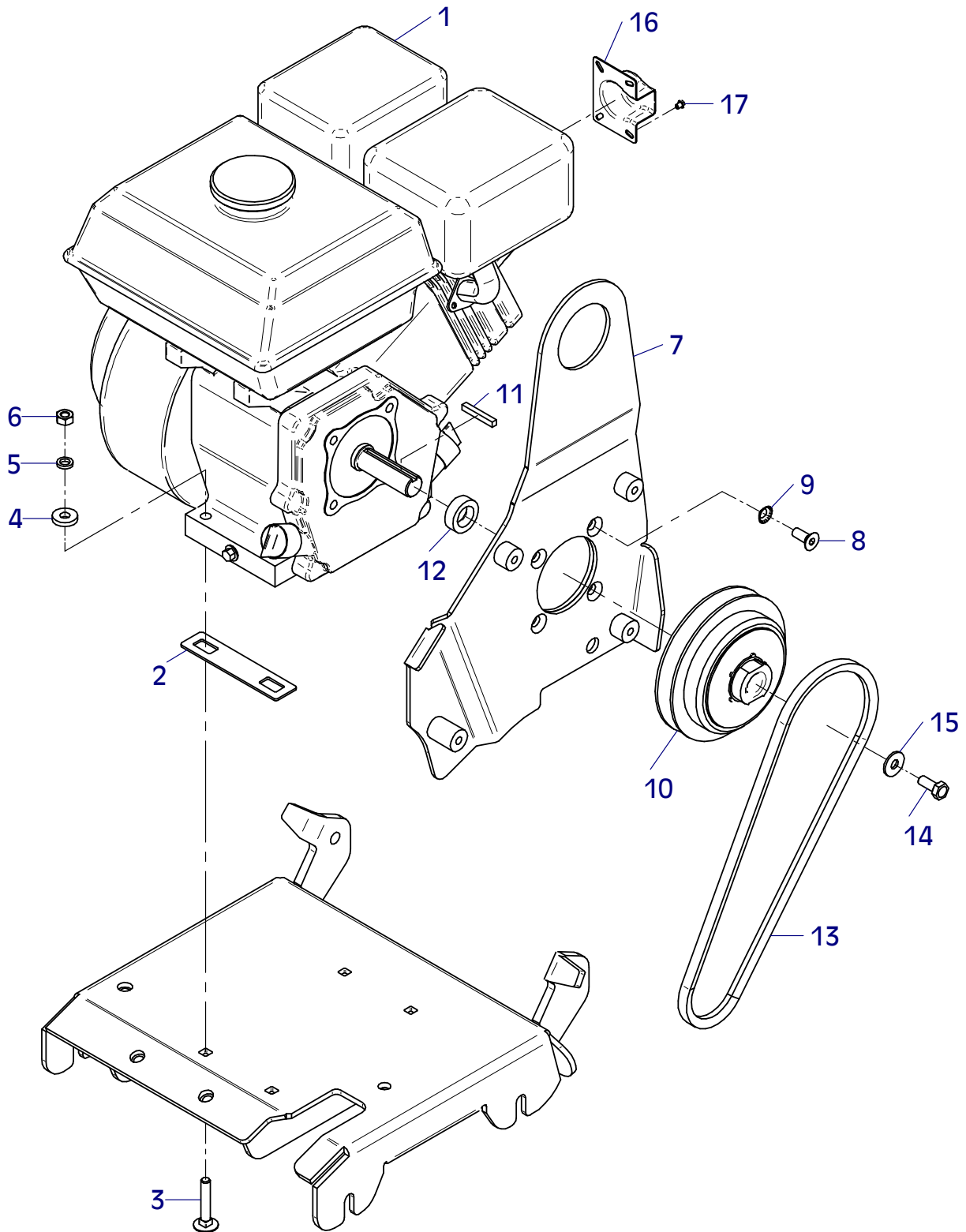

E 3351-0310

Position Ref.No. Repère Posizione Posicion	Menge Quantity Quantité Quantita Cantidad	Teile-Nr. Part-No. No. Référence Nr. d'Ordine No. Referenzia	Hinweis Hints Indications Indicazione Indicaciones	Position Ref. No. Repère Posizione Posicion	Menge Quantity Quantité Quantita Cantidad	Teile-Nr. Part-No. No. Référence Nr. d'Ordine No. Referenzia	Hinweis Hints Indications Indicazione Indicaciones
1	1	21000501					
2	2	20002285					
3	2	21000594					
4	2	20002223					

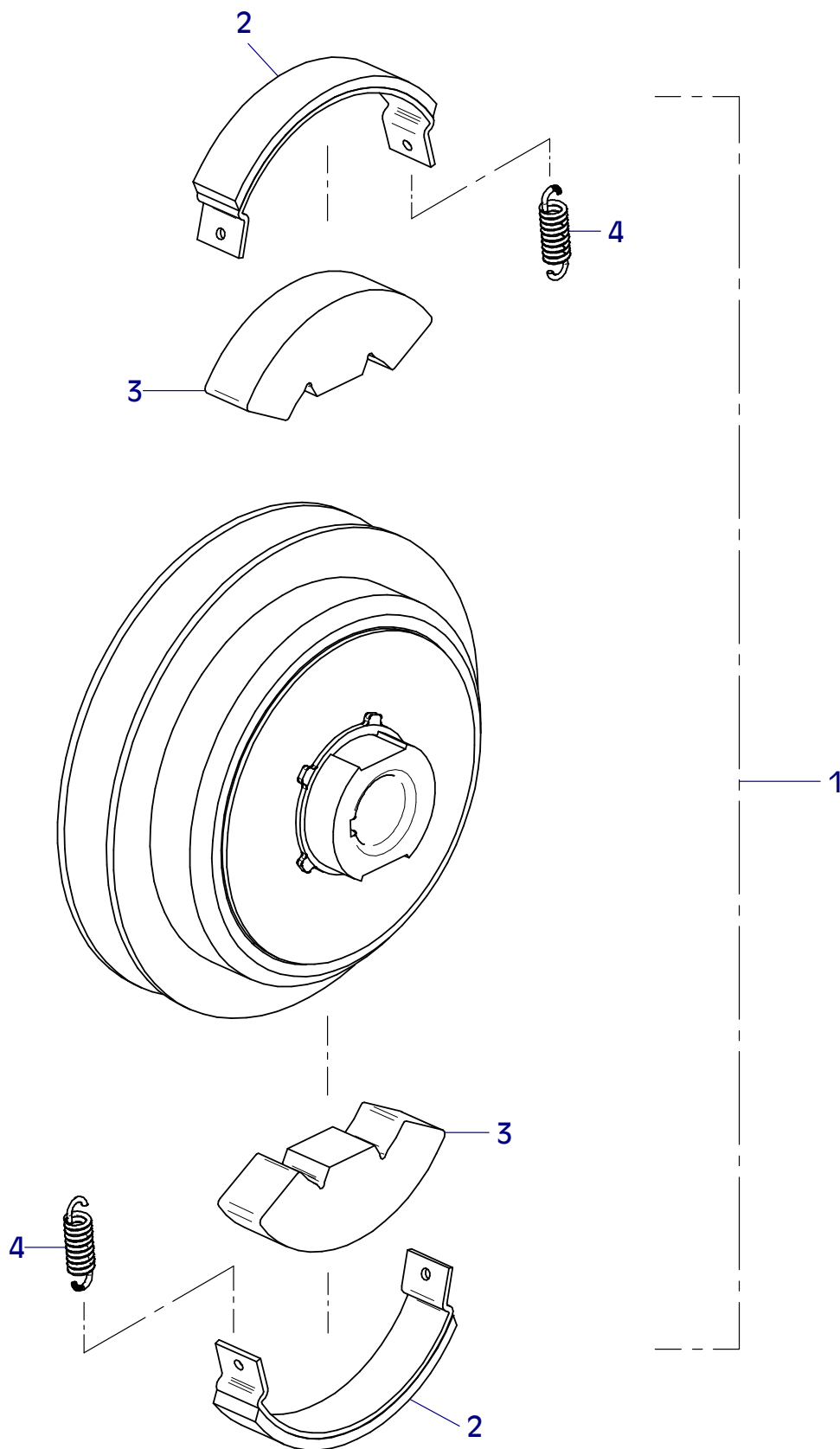

E 3405-1211

Position Ref.No. Repère Posizione Posicion	Menge Quantity Quantité Quantita Cantidad	Teile-Nr. Part-No. No. Référence Nr. d'Ordine No. Referenzia	Hinweis Hints Indications Indicazione Indicaciones	Position Ref. No. Repère Posizione Posicion	Menge Quantity Quantité Quantita Cantidad	Teile-Nr. Part-No. No. Référence Nr. d'Ordine No. Referenzia	Hinweis Hints Indications Indicazione Indicaciones
1	1	11000947					
2	1	11000948					
3	2	20025015					
4	2	10015958					
5	2	25040013	DIN931-M10x60				
6	2	25049013	DIN440-R11,5				
7	2	20029001	VSK 10				
8	2	25031004	DIN934-M10				
9	1	11000949					
10	2	21000706					
11							
12	2	20005020					
13	2	20029003	VSK 8				
14	2	25031003	DIN934-M8				
15	1	20026465					
16	2	25025191	DIN80705-M20x1,5				

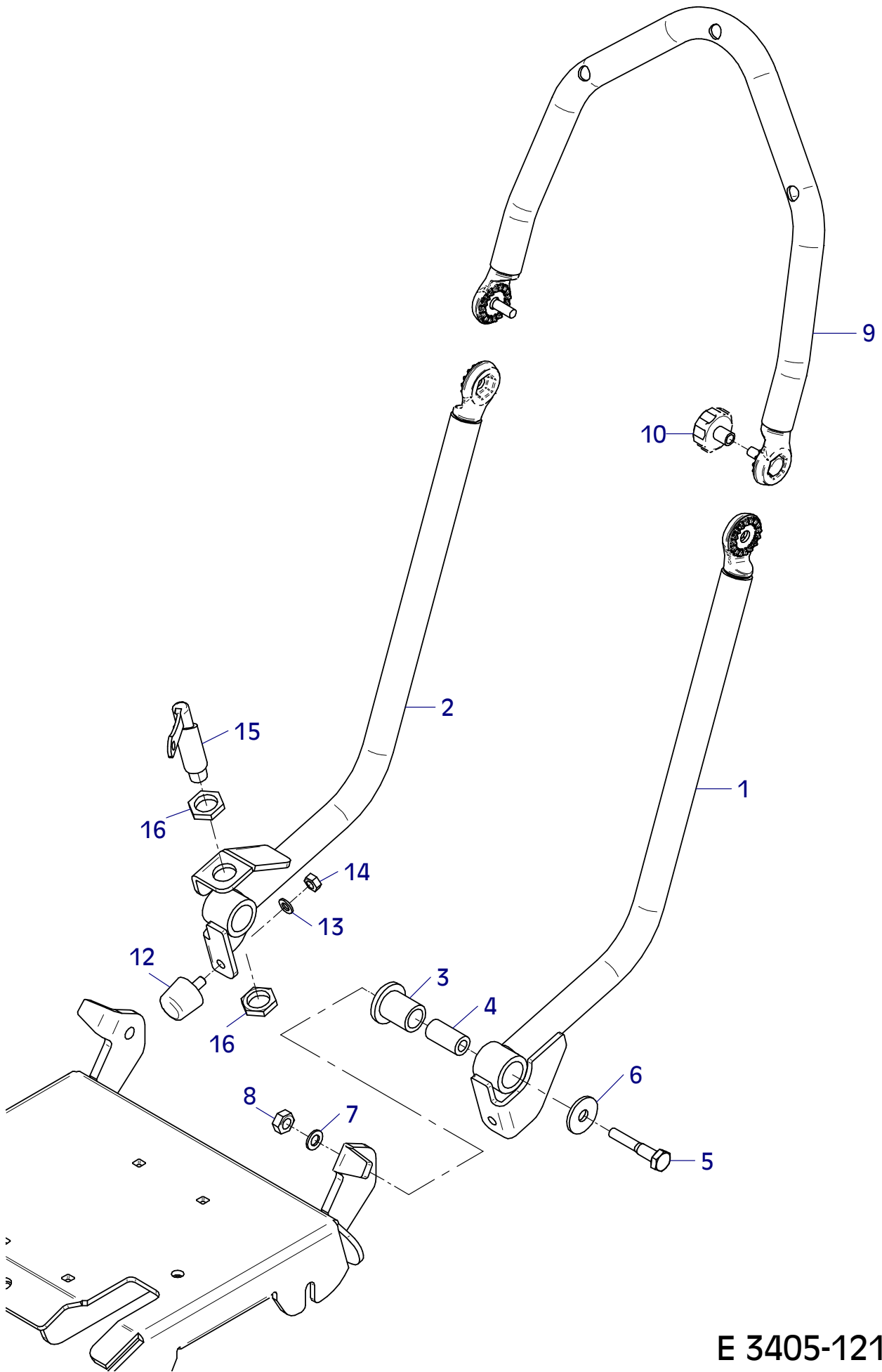

E 3405-1211

E 3406-0911

Position Ref.No. Repère Posizione Posicion	Menge Quantity Quantité Quantità Cantidad	Teile-Nr. Part-No. No. Référence Nr. d'Ordine No. Referenzia	Hinweis Hints Indications Indicazione Indicaciones	Position Ref. No. Repère Posizione Posicion	Menge Quantity Quantité Quantità Cantidad	Teile-Nr. Part-No. No. Référence Nr. d'Ordine No. Referenzia	Hinweis Hints Indications Indicazione Indicaciones
1	2	11000790					
2	1	11000754					
3	7	25044110	DIN912-M6x40				
4	7	25031012	DIN985-M6				
5	2	11001006					
6	2	11001007					
7	2	20029003	VSK 8				
8	2	25038009	DIN933-M8x30				

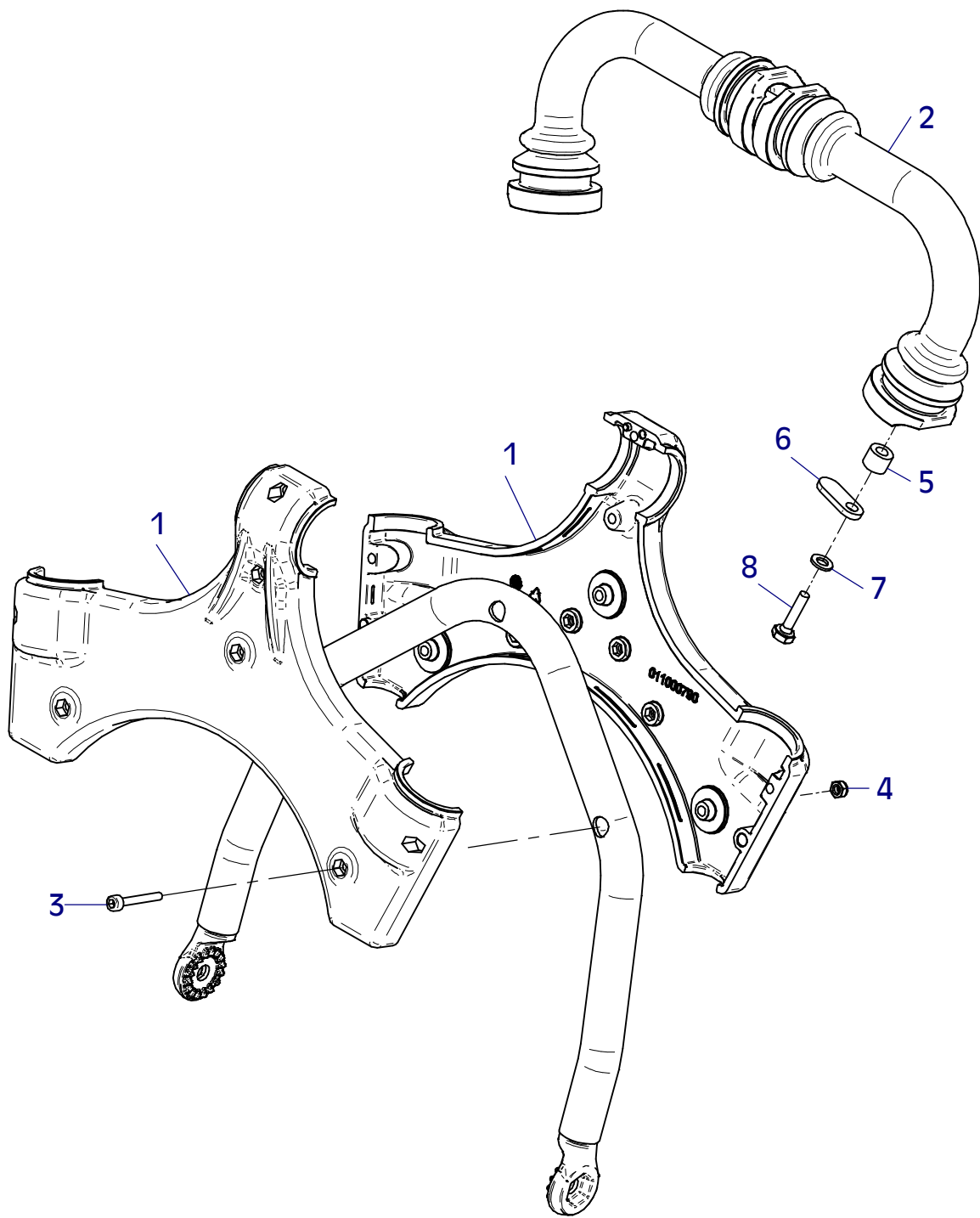

E 3406-0911

E 3505-0313

Position Ref.No. Repère Posizione Posicion	Menge Quantity Quantité Quantita Cantidad	Teile-Nr. Part-No. No. Référence Nr. d'Ordine No. Referenzia	Hinweis Hints Indications Indicazione Indicaciones	Position Ref. No. Repère Posizione Posicion	Menge Quantity Quantité Quantita Cantidad	Teile-Nr. Part-No. No. Référence Nr. d'Ordine No. Referenzia	Hinweis Hints Indications Indicazione Indicaciones
1	1	11001552					
2	2	20025015					
3	2	10015958					
4	2	25040013	DIN931-M10x60				
5	2	25049013	DIN440-R11,5				
6	2	20029001	VSK 10				
7	2	25031004	DIN934-M10				
8	2	20005020					
9	2	20029003	VSK 8				
10	2	25031003	DIN934-M8				
11	1	20026465					
12	2	25025191	DIN80705-M20x1,5				

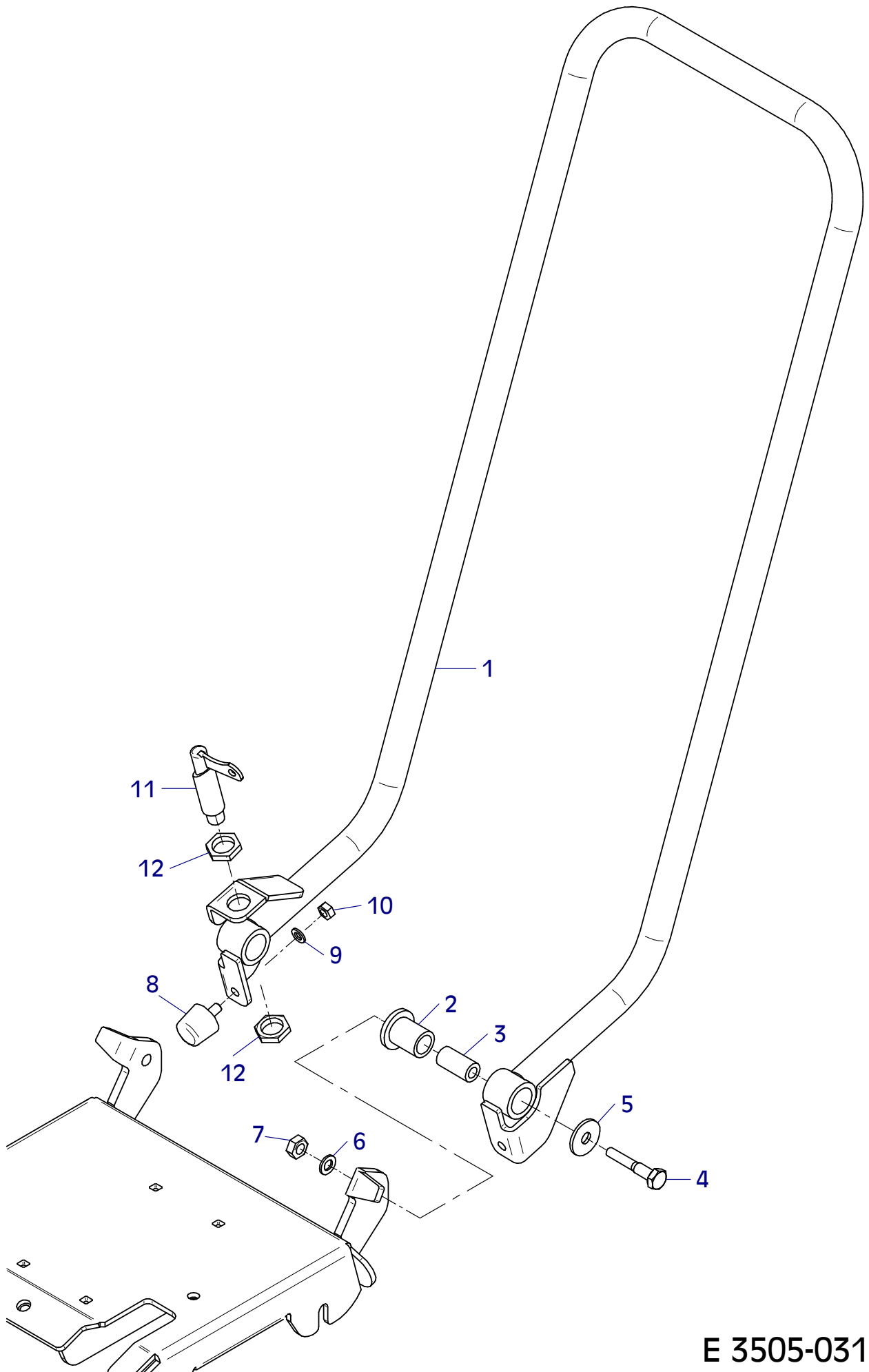

E 3505-0313

E 3407-0612

Position Ref.No. Repère Posizione Posicion	Menge Quantity Quantité Cantidad	Teile-Nr. Part-No. No. Référence Nr. d'Ordine No. Referenzia	Hinweis Hints Indications Indicazione Indicaciones	Position Ref. No. Repère Posizione Posicion	Menge Quantity Quantité Cantidad	Teile-Nr. Part-No. No. Référence Nr. d'Ordine No. Referenzia	Hinweis Hints Indications Indicazione Indicaciones
1	1	21000652					
2	1	20025719					
3	1	11001311					
4	1	11000972					
5	2	20026480					
6	3	11001063					
7	2	21000492	DIN7991-M6x35				
8	1	11001201					
9	3	25047003	DIN7991-M8x16				
10	3	25005003	DIN6798-V8,4				
11	1	11001204					
12	1	21000631	DIN6799-9,0				
13	1	11000966					
14	3	25038014	DIN933-M10x25				
15	3	20029001	VSK 10				
16	2	20005002					
17	2	25031002	DIN934-M6				
18	2	20029007	VSK 6				
19	1	11001205					
20	1	21000094					
21	1	20004031					
22	2	25031003	DIN934-M8				
23	2	20029003	VSK 8				

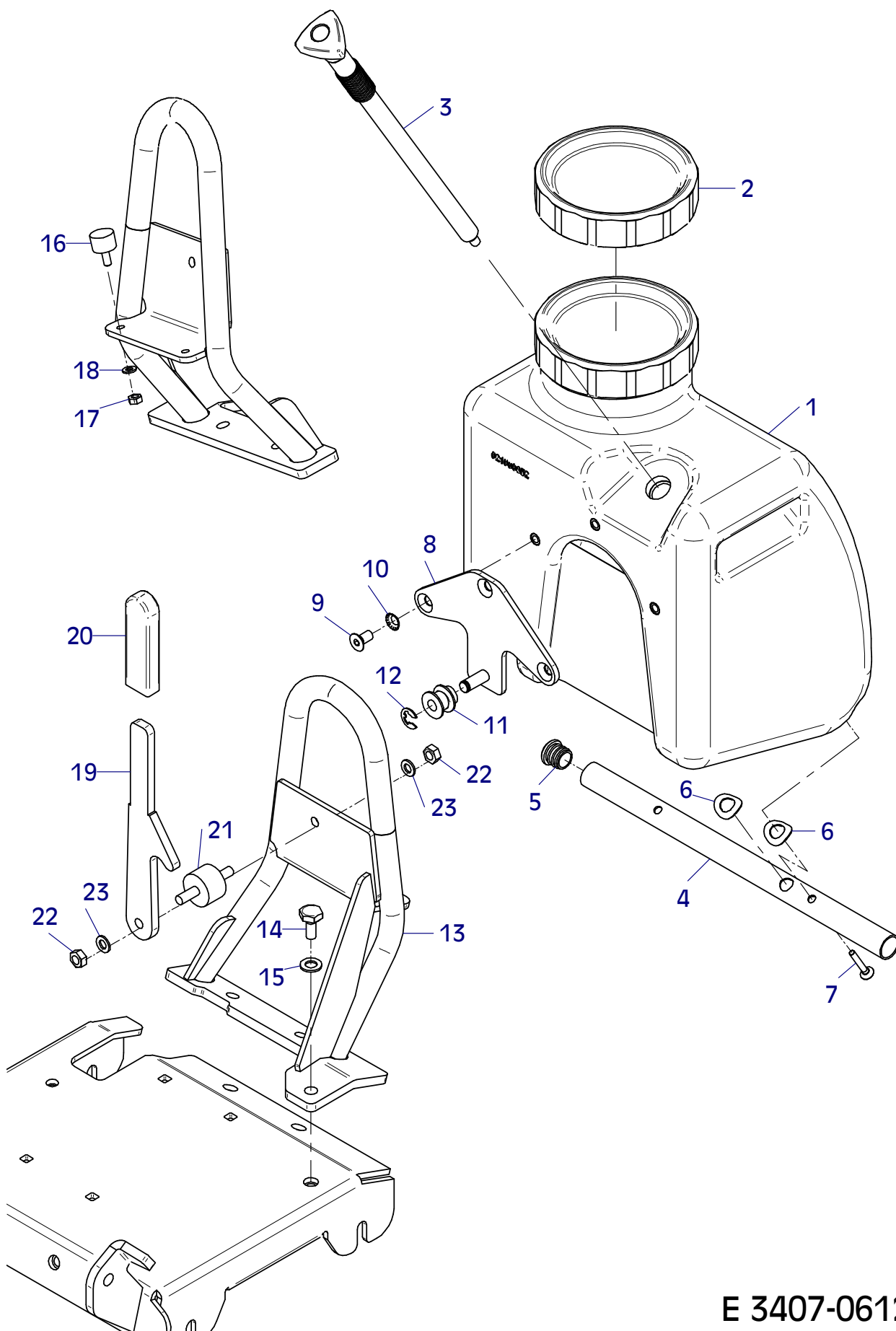

E 3407-0612

E 3408-0911

Position Ref.No. Repère Posizione Posicion	Menge Quantity Quantité Quantita Cantidad	Teile-Nr. Part-No. No. Référence Nr. d'Ordine No. Referenzia	Hinweis Hints Indications Indicazione Indicaciones	Position Ref. No. Repère Posizione Posicion	Menge Quantity Quantité Quantita Cantidad	Teile-Nr. Part-No. No. Référence Nr. d'Ordine No. Referenzia	Hinweis Hints Indications Indicazione Indicaciones
1	1	11000962					
2	2	20025229					
3	2	20026585					
4	2	25049016	DIN440-R9				
5	2	20022012	Tensilock M8x16				
6	1	11000768					
7	2	21000497					
8	1	11000769					
9	1	21000670	DIN931-M10x150				
10	1	25048003	DIN125-A10,5				
11	1	20029001	VSK 10				
12	1	25031004	DIN934-M10				
13	2	25038014	DIN933-M10x25				
14	2	20029001	VSK 10				
15	1	21000491					
16	1	11000767					
17	1	25040011	DIN931-M10x50				
18	2	25048003	DIN125-A10,5				
19	1	20029001	VSK 10				
20	1	25031004	DIN934-M10				

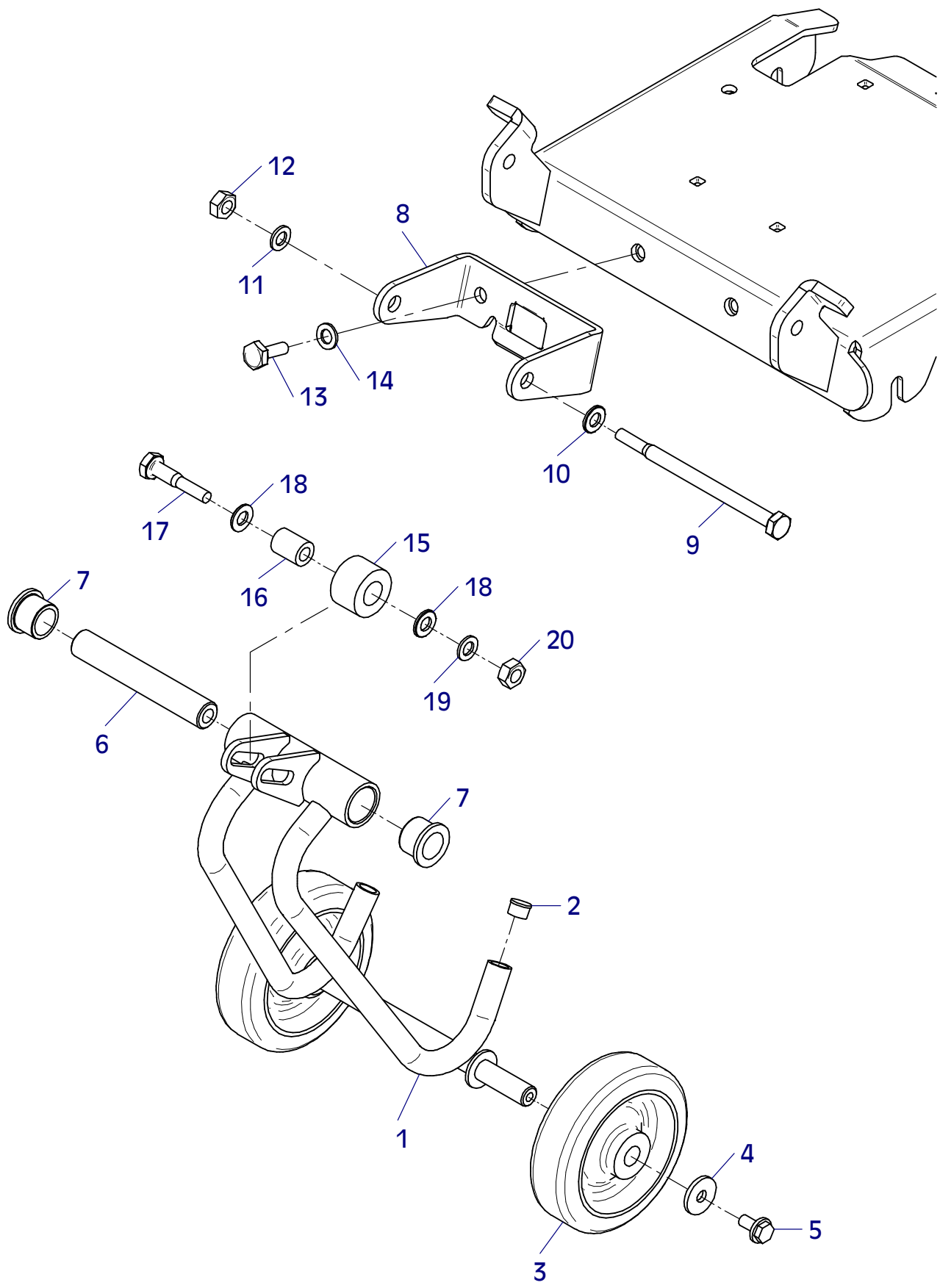

E 3408-0911

E 3452-0512

Position Ref.No. Repère Posizione Posicion	Menge Quantity Quantité Quantita Cantidad	Teile-Nr. Part-No. No. Référence Nr. d'Ordine No. Referenzia	Hinweis Hints Indications Indicazione Indicaciones	Position Ref. No. Repère Posizione Posicion	Menge Quantity Quantité Quantita Cantidad	Teile-Nr. Part-No. No. Référence Nr. d'Ordine No. Referenzia	Hinweis Hints Indications Indicazione Indicaciones
1	1	11001246					
2	1	11001247					
3	2	25040012	DIN931-M10x55				
4	2	25049013	DIN440-R11,5				
5	2	25031014	DIN985-M10				
6	2	11000987					
7	2	11000336					
8	2	25047015	DIN7991-M10x20				

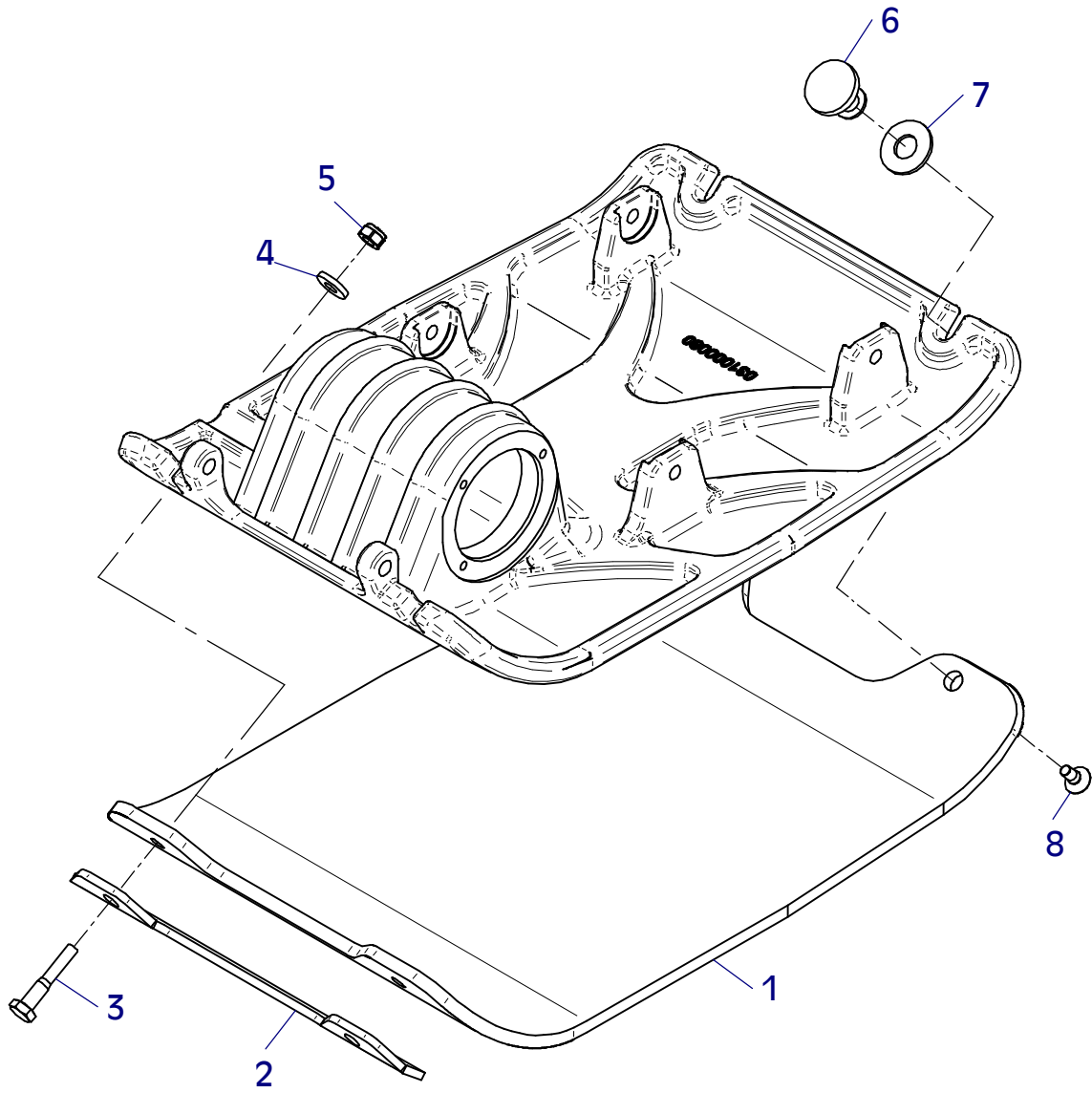

E 3452-0512

E 3575-0614

Position Ref.No. Repère Posizione Posicion	Menge Quantity Quantité Quantita Cantidad	Teile-Nr. Part-No. No. Référence Nr. d'Ordine No. Referenzia	Hinweis Hints Indications Indicazione Indicaciones	Position Ref. No. Repère Posizione Posicion	Menge Quantity Quantité Quantita Cantidad	Teile-Nr. Part-No. No. Référence Nr. d'Ordine No. Referenzia	Hinweis Hints Indications Indicazione Indicaciones
1	1	20019006					
2	1	21000741					
3	1	21000856					
4	1	21000857					
5	1	21000047					
6	1	20019376					
7	1	20019377					
8	1	20019007					
9	1	21000474					
10	1	20019418					
11	1	20019397					
12	1	21000313					
13	1	20019357					
14	1	20019410					
15	1	20019097					
16	1	20019281					
17	1	20019104					
18	1	20019118					
19	1	20019401					
20	1	20019002					
21	1	20019003					
22	1	20019322					

Alle Schraubverbindungen ständig auf festen Sitz überwachen!
-Besonders nach dem ersten Einsatz-

Continuously check all screwed connections for firm seating
-particularly after initial employment-

Controler continuellement tous les raccords a vis pour un siege ferme
-particulierement apres l'emploi initial-

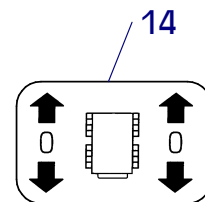
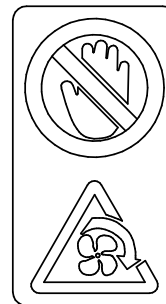
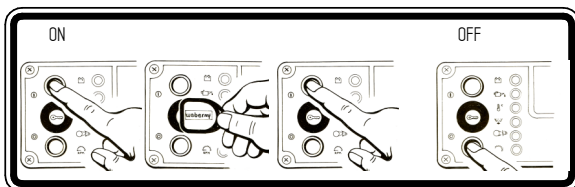
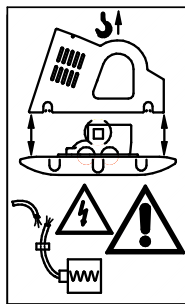
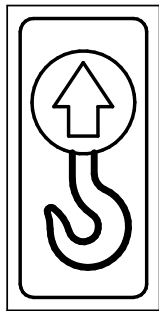
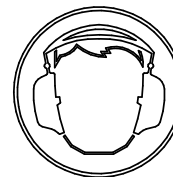
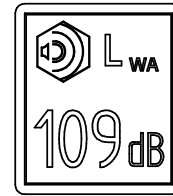
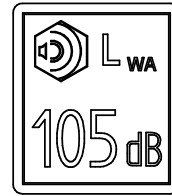
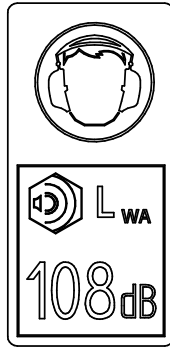
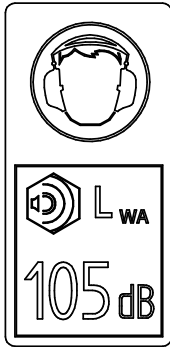
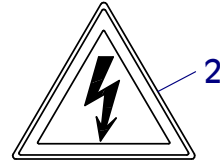

Normalbenzin
Gasoline
Essence

Diesel

Wasser
Water
Eau

HYDRAULIC
OIL

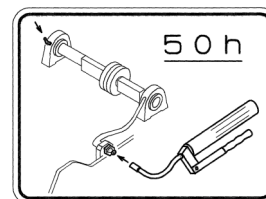
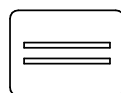
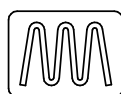
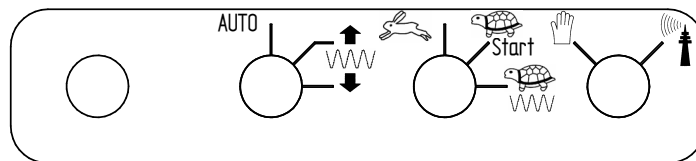

Wenn Sie Fragen, Anregungen, Probleme, usw. haben, wenden Sie sich bitte an eine der unten genannten Adressen:

For problems, questions and further information refer to one of the following addresses:

Si des questions, des suggestions, des problèmes ... survenaient, veuillez vous adresser a l'une des adresses - ci dessous

<p>in Deutschland</p> <p>in Germany</p> <p>Pour l' Allemagne</p>	<p>WEBER Maschinentechnik GmbH 57334 Bad Laasphe – Rückershausen Im Boden 5-8, 10</p>	<p>Telefon Telefax</p> <p>E-Mail</p>	<p>+ 49 (0) 2754 - 398-0 + 49 (0) 2754 - 398101-Zentrale switchboard Central + 49 (0) 2754 - 398102-Ersatzteil-Direktlinie spare parts-directlinie Ligne direct pièces détachées</p> <p>g.voelkel@webermt.de</p>
<p>in Frankreich</p> <p>in France</p> <p>Pour la France</p>	<p>WEBER Technologie SARL 26' rue d' Arsonval 69680 Chassieu</p>	<p>Telefon Telefax</p> <p>E-Mail</p>	<p>+ 33 (0) 472 - 791020 + 33 (0) 472 - 791021</p> <p>france@webermt.com</p>
<p>in Polen</p> <p>in Poland</p> <p>Pour la Pologne</p>	<p>WEBER Maschinentechnik Sp. zo.o. Ul. Grodziska 7 05-830 Stara Wies</p>	<p>Telefon Telefax</p> <p>E-Mail</p>	<p>+ 48 (0) 22 - 739 70 - 80 + 48 (0) 22 - 739 70 - 81 + 48 (0) 22 - 739 70 - 82</p> <p>info@webermt.com.pl</p>
<p>in Tschechien</p> <p>in Czechia</p> <p>Pour la Tchéquie</p>	<p>WEBER MT s.r.o. V Piskovně (areál 5H) Kralupy nad Vítavou 278 01</p>	<p>Telefon</p> <p>E-Mail</p>	<p>+ 42 (0) 776 222 216 + 42 (0) 776 222 261</p> <p>info@webermt.cz</p>
<p>in USA und Kanada</p> <p>in USA and Canada</p> <p>Pour les Etats Unis Et le Canada</p>	<p>WEBER MT, Inc. 45 Dowd Road Bangor, ME 04401</p>	<p>Telefon Telefax</p> <p>E-Mail</p>	<p>+ 1(207) - 947 - 4990 + 1(207) - 947 - 5452</p> <p>sales@webermt.com service@webermt.com</p>
<p>in Süd – Amerika</p> <p>in South – America</p> <p>Pour l' Amérique du sud</p>	<p>WEBER Maschinentechnik do Brasil Máquinas Para Construção Ltda. Rua Curt Wacker, nº 45 93332 – 200 Novo Hamburgo, RS Brasil</p>	<p>Telefon Telefax</p> <p>E-Mail</p>	<p>+ 55 (0) 51- 587 3044 + 55 (0) 51- 587 2271</p> <p>webermt@webermt.com.br</p>

