

CF 1

0100101 - 0100104

Ab Masch.-Nr. 7003009



Spare parts
Spares
Piezas de recambio
Ricambi
Peças de reposição
Piese de schimb
Náhradných dielov
Reservedele
Części zamienne



Weber Maschinentechnik GmbH
D- 57334 Bad Laasphe / Germany
Tel. +49 (0) 2754 / 398-0
Fax. +49 (0)2754 / 398-101
E-Mail: info@webermt.de
www.webermt.com

BITTE, NOTIEREN SIE SERIENNUMMER UND MOTORNUMMER IHRER MASCHINE:

PLEASE WRITE DOWN SERIALNUMBERS OF MACHINE AND ENGINE:

NOTEZ SVP LE NUMERO DE SERIE ET LE NUMERO DU MOTEUR DE VOTRE MACHINE:

SI PREGA DI ANNOTARE SEMPRE I NUMERI DI SERIE SIA DELLA VS. MACCHINA CHE DEL MOTORE:

MAQUINA: ROGAMOS ANOTEN EL NUMERO DE SERIE Y NUMERO DE MOTOR DE SU MAQUINA:

PROSIMY ZANOTOWAĆ NUMER MASZYNY I SILNIKA

MASCHINE
MACHINE
MACCHINA
MAQUINA
MASZYNA

MOTOR
ENGINE
MOTEUR
MOTORE
SILNIK

ZUR VERMEIDUNG VON FEHLLIEFERUNGEN UND VERZÖGERUNGEN SIND BEI DER BESTELLUNG VON ERSATZTEILEN FOLGENDE ANGABEN UNBEDINGT ERFORDERLICH:

- MASCHINENTYP
- SERIENNUMMER DER MASCHINE
- SERIENNUMMER DES MOTORS (BEI MOTORTEILEN)
- TEILENUMMER
- BESTELLMENGE

TO AVOID ERRORS IN DELIVERY PLEASE STATE THESE PARTICULARS WHEN ORDERING:

- TYPE OF MACHINE
- SERIAL NO. OF MACHINE
- SERIAL NO. OF ENGINE (ON ENGINE PARTS)
- PART-NO.
- QUANTITY REQUIRED

AFIN D'EVITER DES ERREURS DE COMMANDE ET DES RETARDS DE LIVRAISON IL EST NECESSAIRE D'INDIQUER LES CARACTERISTIQUES SUIVANTES:

- TYPE DE MACHINE
- LE NUMERO DE SERIE DE LA MACHINE
- LE NUMERO DE SERIE DU MOTEUR
- LE NUMERO D'IDENTITE DE LA PIECE
- LA QUANTITE SOUHAITEE

ONDE EVITARE DISGUIDI E RITARDI NELLE CONSEGNE DIE RICAMBI SI PREGA DI INDICARE SEMPRE:

- TIPO DELLA MACCHINA
- NUMERO DI SERIE DELLA MACCHINA
- NUMERO DI SERIE DEL MOTORE (SE SI RICHIEDONO PEZZI DEL MOTORE)
- NUMERO D'ORDINE DIE SINGOLI RICAMBI
- QUANTITA

A FI DE EVITAR ERRORES DE ENTREGA, ROGAMOS INDIQUEN LOS SIGUIENTES DATOS CUANDO PASE PEDIDOS DE RECAMBIO:

- MODELO DE MAQUINA
- NO. DE SERIE DE LA MAQUINA
- NO. DE SERIE DEL MOTOR (EN PIEZAS PARA MOTOR)
- REFERENCIA DEL RECAMBIO
- CANTIDAD PEDIDA

PROSIMY O PODANIE NASTĘPUJĄCYCH DANYCH PRZY SKŁADANIU ZAMÓWIENIA.

- TYP MASZYNY
- NUMER SERYJNY MASZYNY
- NUMER SERYJNY SILNIKA (PRZY CZĘŚCIACH DO SILNIKA)
- NUMER CZĘŚCI ZAMIEWNEJ
- ZAMAWIANA ILOŚĆ

E 3008-0102

Position Ref.No. Repère Posizione Posicion	Menge Quantity Quantité Quantità Cantidad	Teile-Nr. Part-No. No. Référence Nr. d'Ordine No. Referenzia	Hinweis Hints Indications Indicazione Indicaciones	Position Ref. No. Repère Posizione Posicion	Menge Quantity Quantité Quantità Cantidad	Teile-Nr. Part-No. No. Référence Nr. d'Ordine No. Referenzia	Hinweis Hints Indications Indicazione Indicaciones
1	1	10016242		30	1	10016243	
2	1	20025811		31	1	10016392	
3	1	10016281		32	3	25048002	DIN125-A8,4
4	1	10016419		33	3	20029003	VSK 8
5	1	10005346		34	3	25044005	DIN912-M8x20
6	1	25005003	DIN6798-V8,4	35	1	10016441	
7	1	10016302					
8	1	10016403					
9	2	20029012	VSKZ 10				
10	2	25044009	DIN912-M8x45				
11	6	20029003	VSK 8				
12	6	25038007	DIN933-M8x20				
13	1	10016280					
14	1	20013281					
15	1	25030002	DIN908-M14x1,5				
16	4	20004038					
17	4	25049020	DIN7349-10,5				
18	4	20029001	VSK 10				
19	4	25031004	DIN934-M10				
20	4	20029022	SKB 10				
21	4	25031004	DIN934-M10				
22	1	10016278					
23	1	10016279					
24	2	20029025					
25	2	25044037	DIN912-M10x55				
26	2	25001151					
27	1	25017007					
28	2	20025029	DIN988-PS-56x72x0,2				
29	2	20025528	DIN988-PS-56x72x0,1				

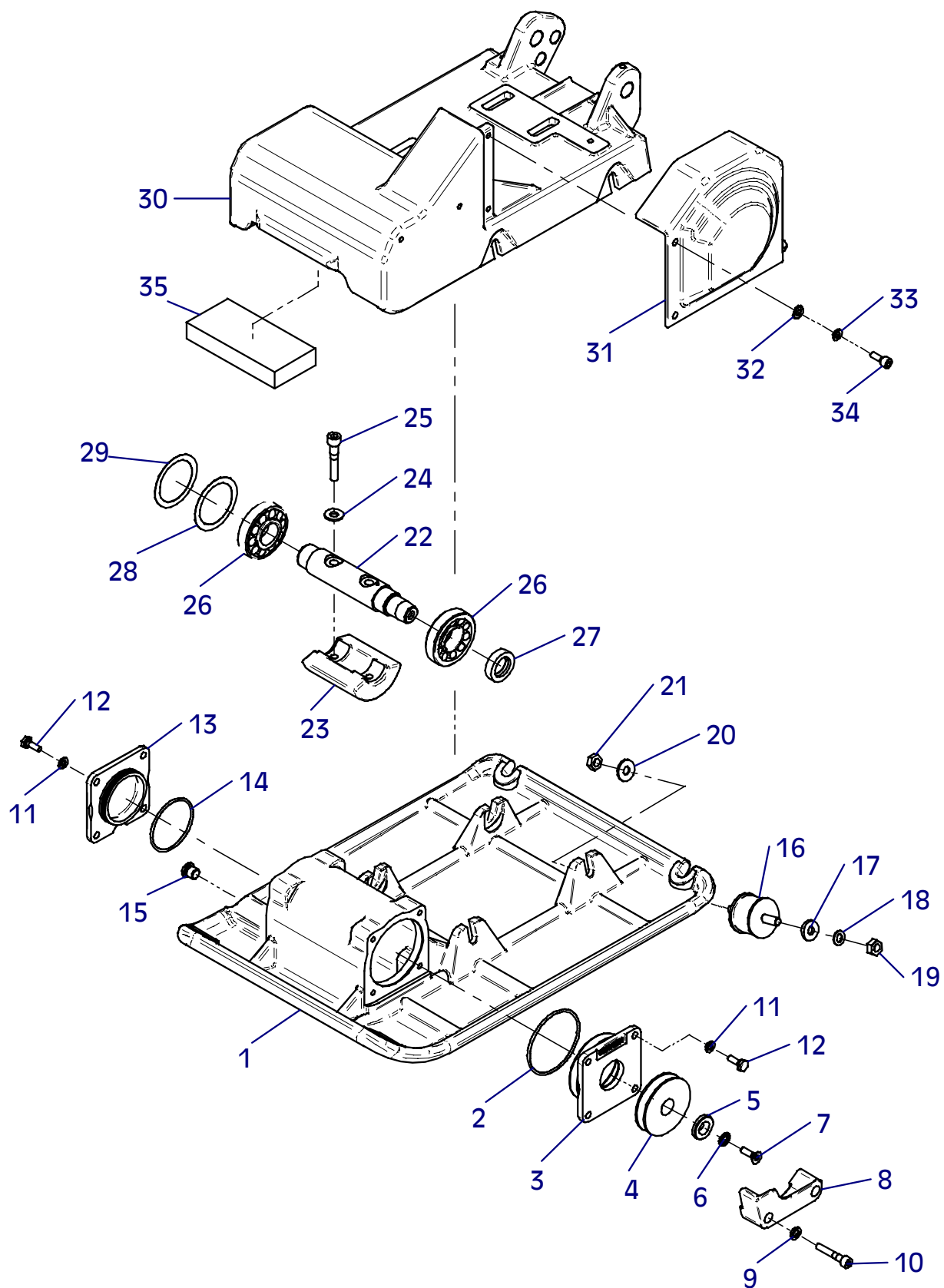

E 3248-0107

Position Ref.No. Repère Posizione Posicion	Menge Quantity Quantité Quantita Cantidad	Teile-Nr. Part-No. No. Référence Nr. d'Ordine No. Referenzia	Hinweis Hints Indications Indicazione Indicaciones	Position Ref. No. Repère Posizione Posicion	Menge Quantity Quantité Quantita Cantidad	Teile-Nr. Part-No. No. Référence Nr. d'Ordine No. Referenzia	Hinweis Hints Indications Indicazione Indicaciones
1	1	21000080					
2	1	30047634					
3	4	20029021	SKB 8				
4	4	25038007	DIN933-M8x20				
5	1	21000136					
6	1	25002021					
7	1	20029021	SKB 8				
8	1	25040065	DIN931-M8x40				
9	1	10017345					
10	2	10017346					
11	4	25033041	DIN603-M8x70				
12	4	25049026	DIN7349-8,4				
13	4	20029024					
14	4	25031003	DIN934-M8				

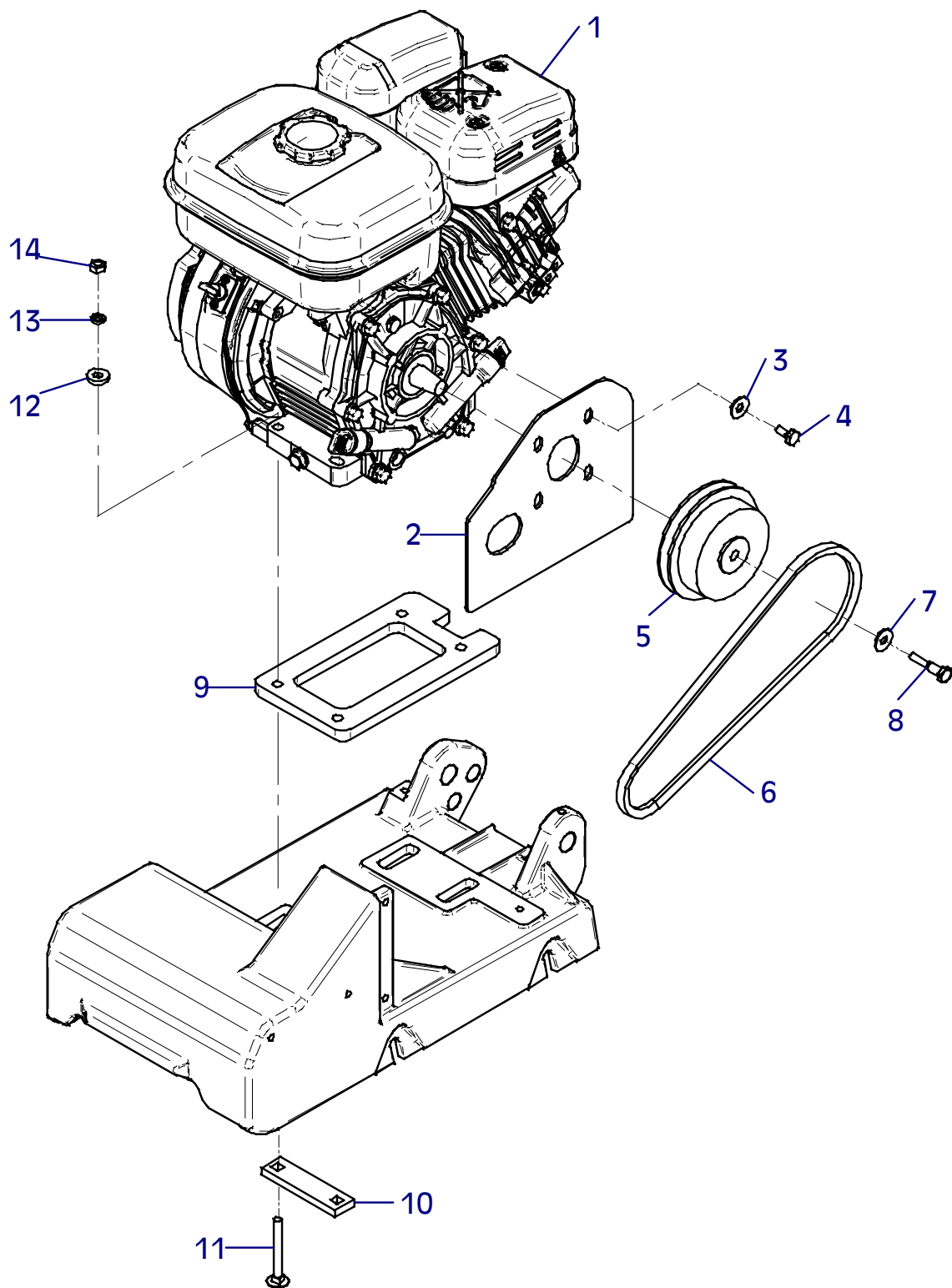

E 3249-0107

Position Ref.No. Repère Posizione Posicion	Menge Quantity Quantité Quantita Cantidad	Teile-Nr. Part-No. No. Référence Nr. d'Ordine No. Referenzia	Hinweis Hints Indications Indicazione Indicaciones	Position Ref. No. Repère Posizione Posicion	Menge Quantity Quantité Quantita Cantidad	Teile-Nr. Part-No. No. Référence Nr. d'Ordine No. Referenzia	Hinweis Hints Indications Indicazione Indicaciones
1	1	21000136					
2	2	20002337					
3	2	20002232					
4	2	21000255					

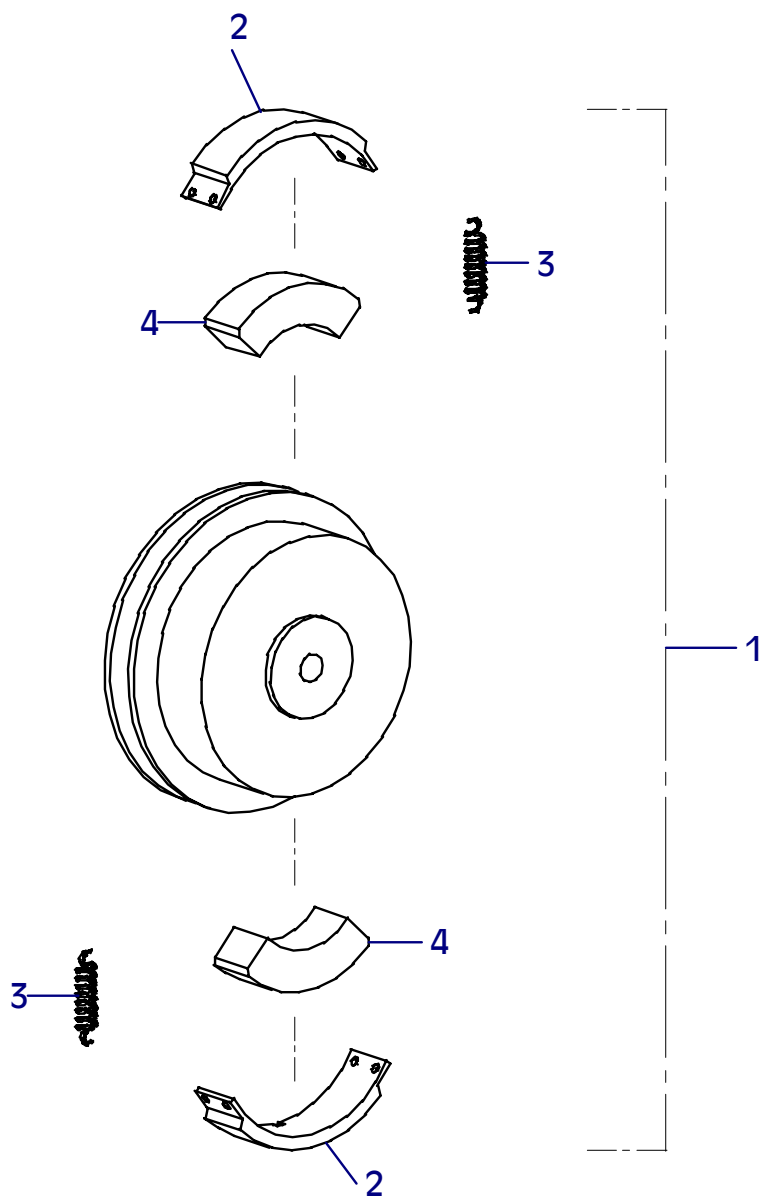

E 3010-0610

Position Ref.No. Repère Posizione Posicion	Menge Quantity Quantité Quantità Cantidad	Teile-Nr. Part-No. No. Référence Nr. d'Ordine No. Referenzia	Hinweis Hints Indications Indicazione Indicaciones	Position Ref. No. Repère Posizione Posicion	Menge Quantity Quantité Quantità Cantidad	Teile-Nr. Part-No. No. Référence Nr. d'Ordine No. Referenzia	Hinweis Hints Indications Indicazione Indicaciones
1	1	21000607					
2	1	10005238					
3	1	30047634					
4	4	25033041	DIN603-M8x70				
5	4	20029021	SKB 8				
6	4	25043005	DIN933-5/16"				
7	2	10016088					
8	1	20002101					
9	1	25002021					
10	1	20029021	SKB 8				
11	1	25043005	DIN933-5/16"				
12	1	10017345					
13	2	10017346					
14	4	25049026	DIN7349-8,4				
15	4	20029024					
16	4	25031003	DIN934-M8				
17	1	21000610					
18	2	20026389					

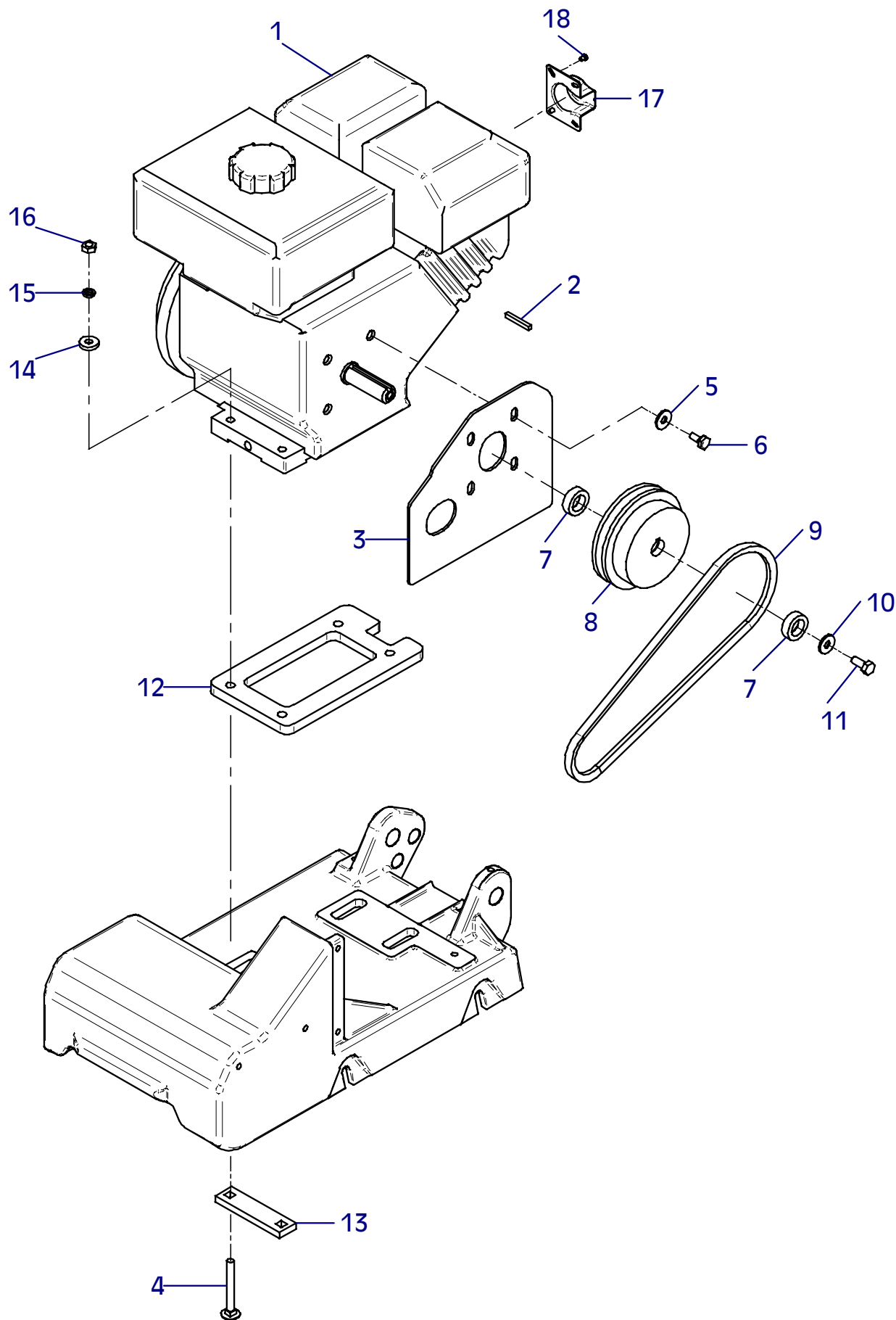

E 3175-0107

Position Ref.No. Repère Posizione Posicion	Menge Quantity Quantité Quantita Cantidad	Teile-Nr. Part-No. No. Référence Nr. d'Ordine No. Referenzia	Hinweis Hints Indications Indicazione Indicaciones	Position Ref. No. Repère Posizione Posicion	Menge Quantity Quantité Quantita Cantidad	Teile-Nr. Part-No. No. Référence Nr. d'Ordine No. Referenzia	Hinweis Hints Indications Indicazione Indicaciones
1	1	20002101					
2	2	20002337					
3	2	20002223					
4	2	21000255					

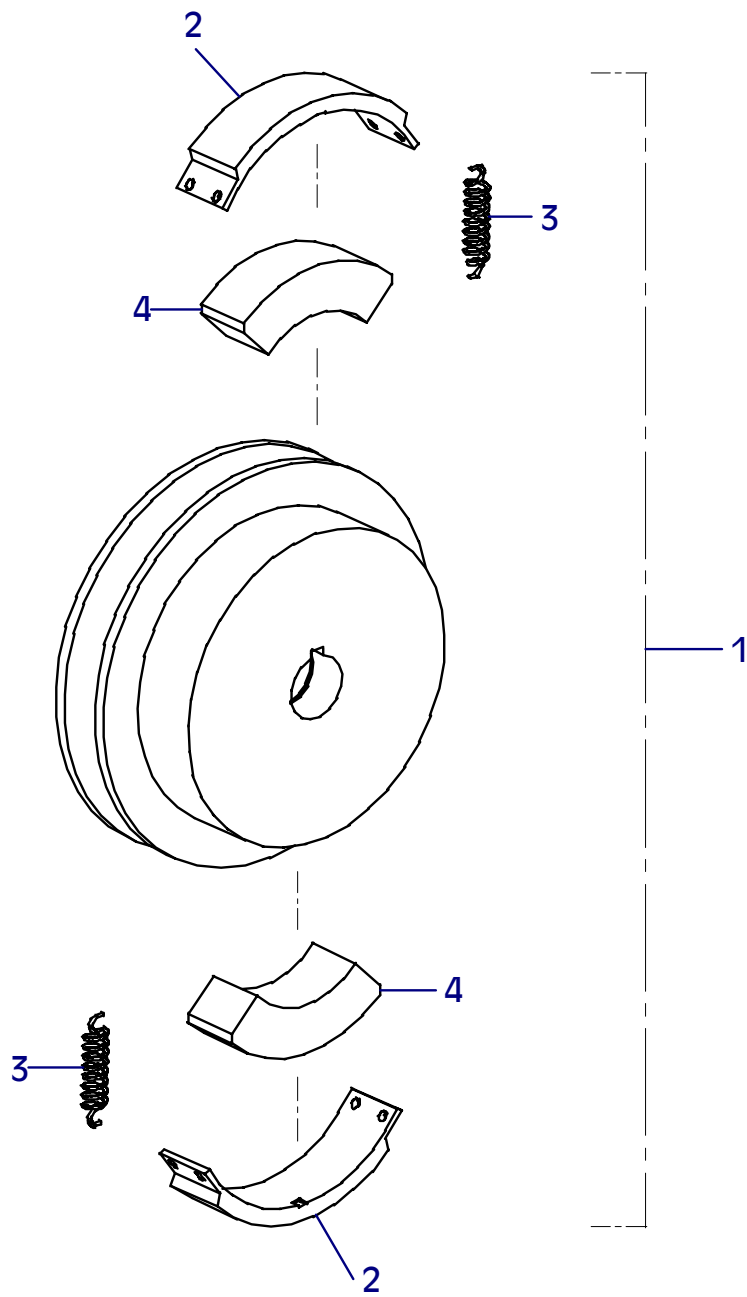

E 3011-0102

Position Ref.No. Repère Posizione Posicion	Menge Quantity Quantité Quantita Cantidad	Teile-Nr. Part-No. No. Référence Nr. d'Ordine No. Referenzia	Hinweis Hints Indications Indicazione Indicaciones	Position Ref. No. Repère Posizione Posicion	Menge Quantity Quantité Quantita Cantidad	Teile-Nr. Part-No. No. Référence Nr. d'Ordine No. Referenzia	Hinweis Hints Indications Indicazione Indicaciones
1	1	10022515					
2	2	20005012					
3	2	25048002	DIN125-A8,4				
4	2	20029003	VSK 8				
5	2	25025092					
6	1	20025621					
7	1	20025019					
8	2	25025191	DIN80705-M20x1,5				
9	1	10016282					
10	2	20025335					
11	2	25049016	DIN440-R9				
12	2	20029003	VSK 8				
13	2	25038007	DIN933-M8x20				
14	2	25027004	DIN914-M8x16				

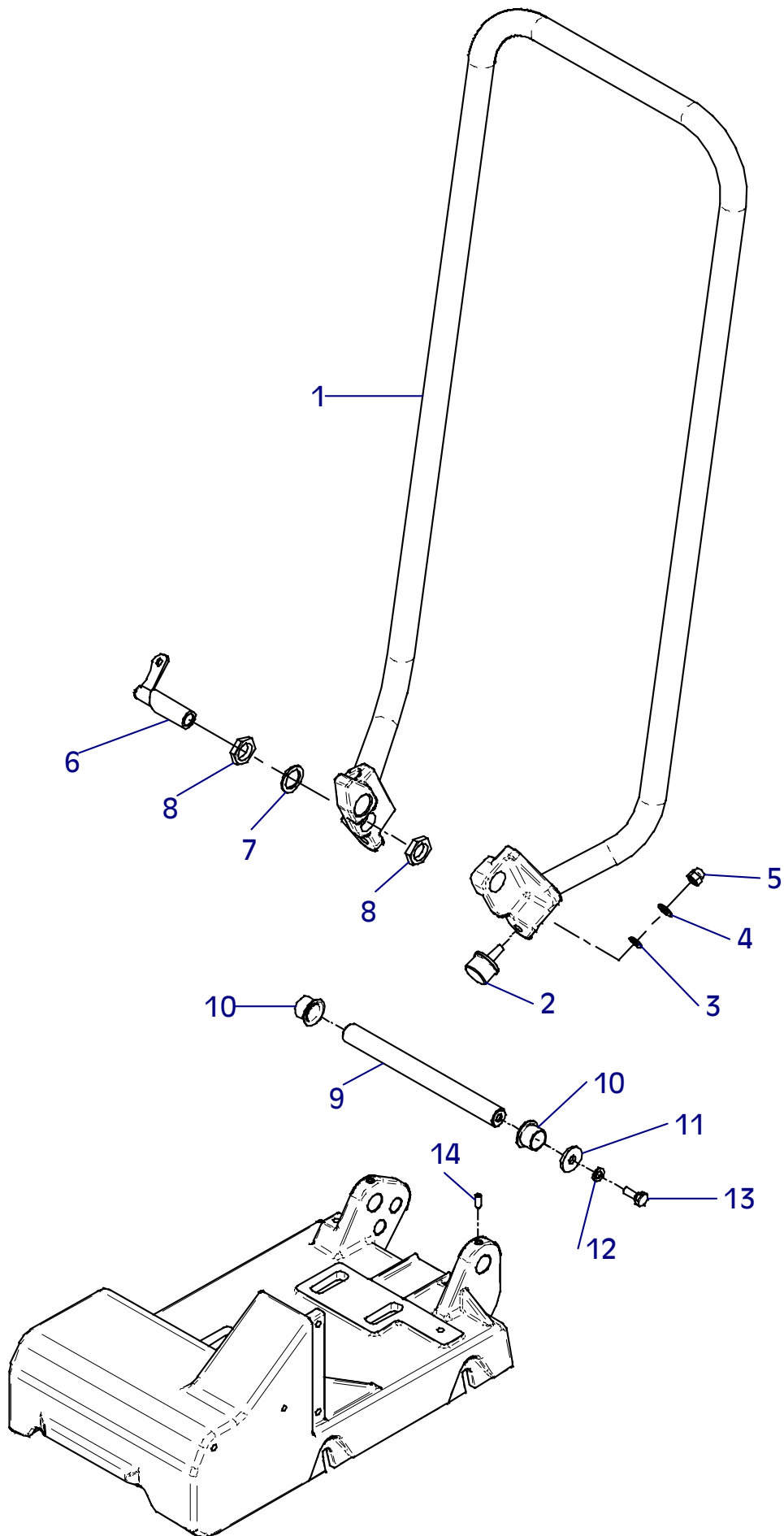

E 3011-0102

E 3012-0102

Position Ref.No. Repère Posizione Posicion	Menge Quantity Quantité Quantità Cantidad	Teile-Nr. Part-No. No. Référence Nr. d'Ordine No. Referenzia	Hinweis Hints Indications Indicazione Indicaciones	Position Ref. No. Repère Posizione Posicion	Menge Quantity Quantité Quantità Cantidad	Teile-Nr. Part-No. No. Référence Nr. d'Ordine No. Referenzia	Hinweis Hints Indications Indicazione Indicaciones
1	1	10022542					
2	2	20026585					
3	2	25049016	DIN440-R9				
4	2	20022012	Tensilock M8x16				
5	1	20005012					
6	1	20029003	VSK 8				
7	1	25031003	DIN934-M8				
8	1	10016284					
9	2	20026466					
10	1	25036024					
11	1	10022543					
12	1	20026481					
13	2	25025191	DIN80705-M20x1,5				
14	1	20025019					
15	2	25038014	DIN933-M10x25				
16	2	20029001	VSK 10				
17	2	25048003	DIN125-A10,5				
18	1	10016436					

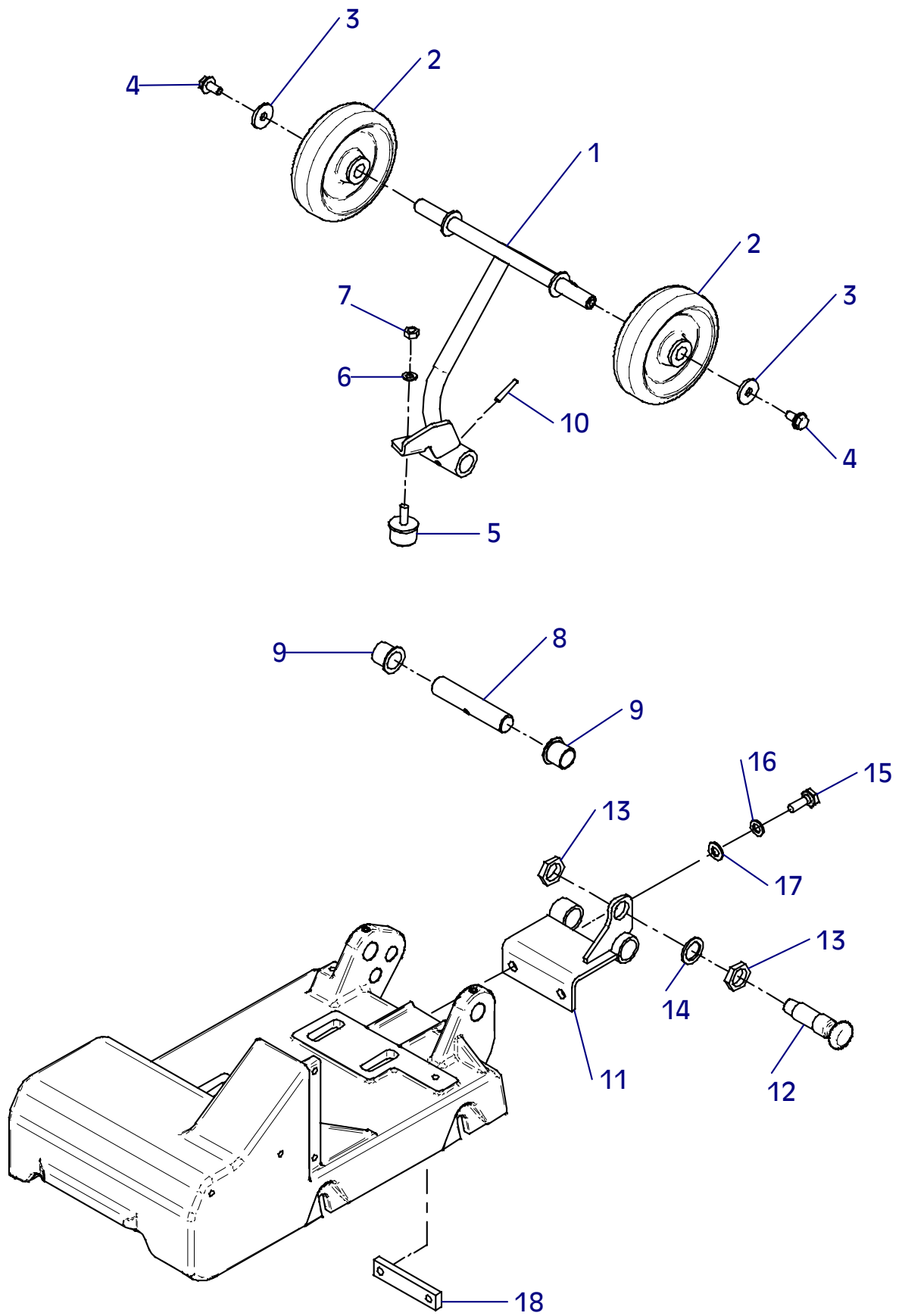

E 3012-0102

E 3013-0708

Position Ref.No. Repère Posizione Posicion	Menge Quantity Quantité Quantita Cantidad	Teile-Nr. Part-No. No. Référence Nr. d'Ordine No. Referenzia	Hinweis Hints Indications Indicazione Indicaciones	Position Ref. No. Repère Posizione Posicion	Menge Quantity Quantité Quantita Cantidad	Teile-Nr. Part-No. No. Référence Nr. d'Ordine No. Referenzia	Hinweis Hints Indications Indicazione Indicaciones
1	1	20026478					
2	1	20025719					
3	1	20030018					
4	1	20030016					
5	1	20030010					
6	1	20013292					
7	2	30047165					
8	4	25040027	DIN931-M8x35				
9	4	20029003	VSK 8				
10	1	10016283					
11	2	20025775					
12	2	20026480					

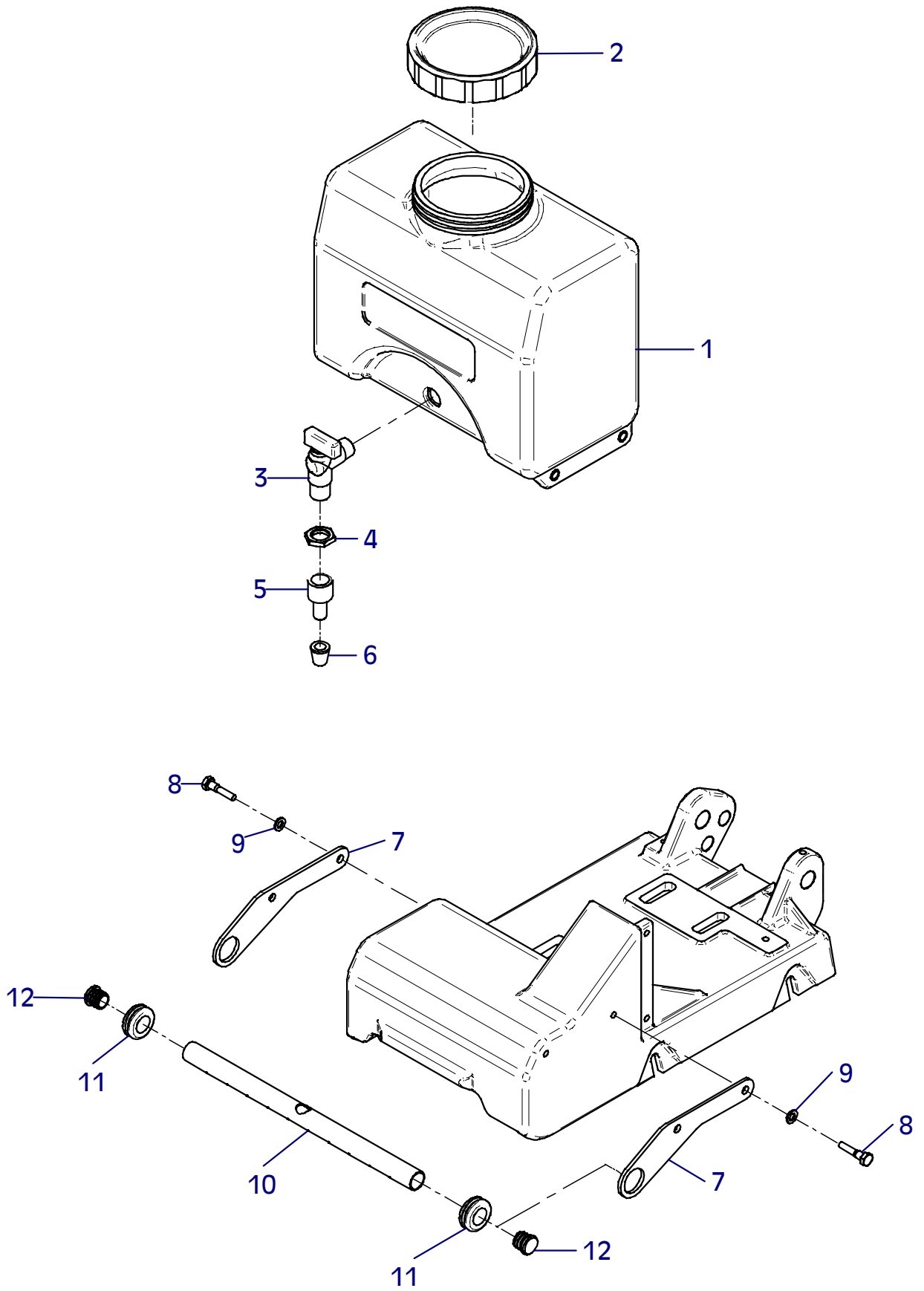

E 3013-0708

E 3014-1008

Position Ref.No. Repère Posizione Posicion	Menge Quantity Quantité Quantità Cantidad	Teile-Nr. Part-No. No. Référence Nr. d'Ordine No. Referenzia	Hinweis Hints Indications Indicazione Indicaciones	Position Ref. No. Repère Posizione Posicion	Menge Quantity Quantité Quantità Cantidad	Teile-Nr. Part-No. No. Référence Nr. d'Ordine No. Referenzia	Hinweis Hints Indications Indicazione Indicaciones
1	1	10016429					
2	1	11000163					
3	2	25049013	DIN440-R11,5				
4	2	25031014	DIN985-M10				
5	2	10016430					
6	2	25048003	DIN125-A10,5				
7	2	25047044	DIN7991-M10x25				
8	2	25038054	DIN933-M10x65				
9	2	11000336					

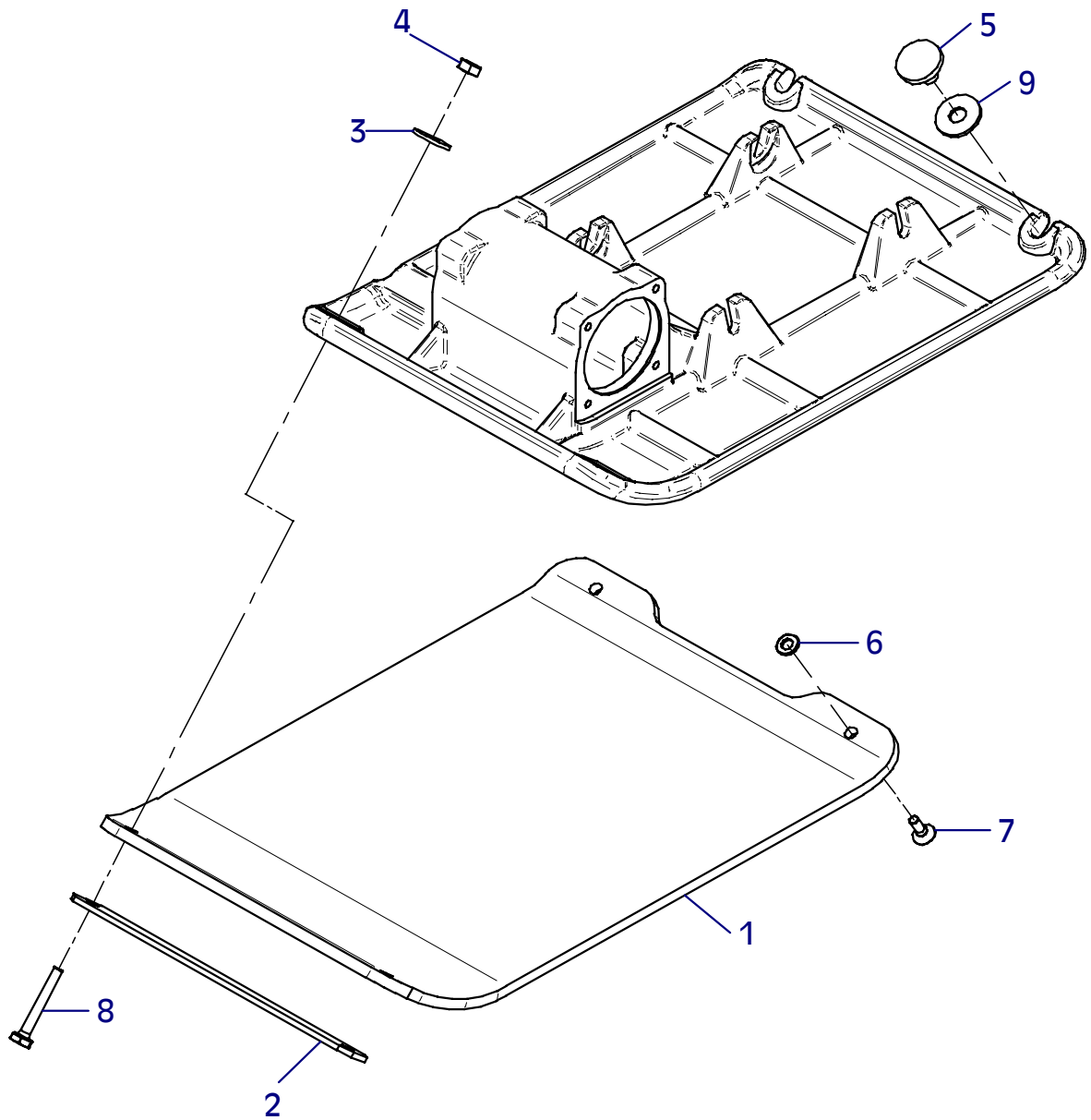

E 3014-1008

Wenn Sie Fragen, Anregungen, Probleme, usw. haben, wenden Sie sich bitte an eine der unten genannten Adressen:

For problems, questions and further information refer to one of the following addresses:

Si des questions, des suggestions, des problèmes ... survenaient, veuillez vous adresser a l'une des adresses - ci dessous

<p>in Deutschland</p> <p>in Germany</p> <p>Pour l' Allemagne</p>	<p>WEBER Maschinentechnik GmbH 57334 Bad Laasphe – Rückershausen Im Boden 5-8, 10</p>	<p>Telefon + 49 (0) 2754 - 398-0 Telefax + 49 (0) 2754 - 398101-Zentrale switchboard Central + 49 (0) 2754 - 398102-Ersatzteil-Direktlinie spare parts-directlinie Ligne direct pièces détachées</p> <p>E-Mail g.voelkel@webermt.de</p>
<p>in Frankreich</p> <p>in France</p> <p>Pour la France</p>	<p>WEBER Technologie SARL 26' rue d' Arsonval 69680 Chassieu</p>	<p>Telefon + 33 (0) 472 -791020 Telefax + 33 (0) 472 – 791021</p> <p>E-Mail france@webermt.com</p>
<p>in Polen</p> <p>in Poland</p> <p>Pour la Pologne</p>	<p>WEBER Maschinentechnik Sp. zo.o. Ul. Grodziska 7 05-830 Stara Wies</p>	<p>Telefon + 48 (0) 22 - 739 70 - 80 Telefax + 48 (0) 22 - 739 70 - 81 + 48 (0) 22 - 739 70 - 82</p> <p>E-Mail info@webermt.com.pl</p>
<p>in USA und Kanada</p> <p>in USA and Canada</p> <p>Pour les Etats Unis Et le Canada</p>	<p>WEBER Machine (USA), Inc. 45 B Dowd Road Bangor, ME 04401</p>	<p>Telefon + 1(207) - 947 - 4990 Telefax + 1(207) - 947 – 5452</p> <p>E-Mail usa@webermt.com</p>
<p>in Süd – Amerika</p> <p>in South – America</p> <p>Pour l' Amérique du sud</p>	<p>WEBER Maschinentechnik do Brasil Máquinas Para Construção Ltda. Rua Curt Wacker, n° 45 93332 – 200 Novo Hamburgo, RS Brasil</p>	<p>Telefon + 55 (0) 51- 587 3044 Telefax + 55 (0) 51- 587 2271</p> <p>E-Mail webermt@webermt.com.br</p>

