

www.serviscentrum.cz

+420 607 607 077

info@serviscentrum.cz



ERSATZTEILLISTE

SPARE PARTS LIST

**LISTE DES PIECES
DE RECHANGE**

LISTINO RICAMBI

LISTA DE RECAMBIOS

**WYKAZ CZESCI
ZAMIENNYCH**



SRV 66

Weber Maschinentechnik GmbH
Postfach 2153, 57329 Bad Laasphe-Rückershausen
Telefon 02754 / 398-0
Telefax (02754) 398-101 (Zentrale) u. 398-102 (Ersatzteile)

09.2006

0170411-0170412

EG - KONFORMITÄTSERKLÄRUNG

EC DECLARATION OF CONFORMITY/ DECLARATION DE CONFORMITE CE
DICHIARAZIONE CE DI CONFORMITA / DECLARACION CE DE CONFORMIDAD
EG-VERKLARING VAN OVEREENSTEMMING / EF-OVERENSSTEMMELSESERKAERING
DECLARACAO CE DE CONFORMIDADE / EG-FÖRSÄKRAN OM ÖVERENSSTÄMMELSE
DEKLARACJA ZGODNOŚCI

im Sinne der EG-Maschinenrichtlinie 98/37/EG und der EG Richtlinie 2000/14/EG - Geräuschemissionen

- I **Hersteller** / Make / Marque / Marca / Marca / Producent / Merk / Marca /
Tiliverkare / Producent **Weber Maschinentechnik GmbH**
Im Boden 5-8,10
57334 Bad Laasphe
- II **Art** / Category / Catégorie / Categoria Tipo / Kategori /
Soort / Categoria / kategori / Typ **Vibrationsstamper**
- III **Typ** / Type / Type / Tipo / Codice / Type / Type / Tipo / Typ **SRV 66**
- IV **Nennleistung** / Nominal-performance / La puissance nominale / Prestazione nominale /
Potencia nominal / Nominaal vermogen / Nominel ydelse / Potência nominal / Nominell
effect / Moc **P = 3,0 kW**
- V **gemessener Schalleistungspegel** / measured sound power level / niveau de
puissance acoustique mesure / livello di potenza sonora rilevato / nivel de potencia
acústica medido / gemeten geluidsvermogensniveau / målt lyd effektiveau / Nivel de
potência sonora midido / uppmätt ljud effekt nivå / Mierzony poziom dźwięku **LWA = 107 dB (A)**
- VI **garantierter Schalleistungspegel** / guaranteed sound power level / niveau de
puissance acoustique garanti / livello di potenza sonora garantito / nivel de potencia
acustica garantizado / gewaarborgd geluidsvermogensniveau / garanteret lyd effektiveau /
Nivel sonoro garantido / garanterad ljud effekt nivå / Natężenie hałasu **LWA = 108 dB (A)**
- VII **beteiligte Zertifizierungsstelle** / notified body involved / de l'organisme notifié/
dell'organismo notificato che l'ha effettuata / dirección del organismo notificado que haya
intervenido / betrokken aangemelde instantie / pagældende bemyndigede organ /
organismo notificado envolvido / berörda anmälda organets namn / Jednostka
certyfikująca **RWTÜV**
Postfach 103161
D-45032 Essen
- VIII **Konformitäts-Bewertungsverfahren** / Conformity assessment procedure followed /
la procédure appliquée pour l'évaluation de la conformité et / procedura di valutazione
della conformità / procedimiento de evaluación de la conformidad / gevolgd
overeenstemmingsbeoordelingsprocedure / den fulgte
overensstemmelssesvurderingsprocedure / procedimento de avaliacao de conformidade
/ Vilket förfarande för bedömning av överensstämmelse / Przebieg kontroli **interne Fertigungskontrolle**
nach Anhang VI
EG Richtlinie 2000/14/EG

ist in Übereinstimmung mit folgenden Richtlinien hergestellt worden / has been produced in accordance with following standards / est produit conforme aux dispositions des directives europeenes ci-apres / ha sido fabricado en conformidad con las siguientes normas / é stato fabbricato in conformità alle sequenti norme / er blevet fremstillet i overensstemmelse med følgende retningslinier / in overeenstemming met de volgende voorschriften gefabriceerd is / é fabricado conforme as seguintes normas / har tillverkats i överensstämmelse med följande riktlinjer / Zgodność z obowiązującymi przepisami

98/37/EG Maschinenrichtlinie des europäischen Parlamentes und des Rates vom 22. Juni 1998
2000/14/EG EG-Richtlinie Geräuschemissionen vom 8. Mai 2000
2005/88/EG EG-Richtlinie vom 14. Dez. 2005 zur Änderung der Richtlinie 2000/14/EG
EN 500 Teil 1 Bewegliche Straßenbaumaschinen – Sicherheit
Gemeinsame Anforderungen
EN 500 Teil 4 Bewegliche Straßenbaumaschinen – Sicherheit
Besondere Anforderungen an Verdichtungsmaschinen

Bescheinigung bitte sorgfältig aufbewahren / File certificate carefully / Conserver certificat soigneusement / Conservar certificado cuidadosamente / Pregasi conservare accuratamente certificato / Beviset bedes opbevares omhyggeligt / Verklaring a.u.b. zorgvuldig bevar / Conservar o certificado com cuidado / Beviset skall om sorgsfullt bevaras // Deklarację zgodności proszę zachować

Bad Laasphe – Rückershausen, den **02.01.2006**

W. Weber, Geschäftsführer

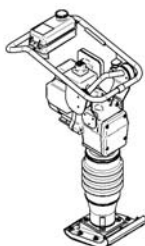

webermt

WEBER Maschinentechnik GmbH
Im Boden 5-8, 10 – D-57334 Bad Laasphe
Postfach 2153 – D-57329 Bad Laasphe
Telefon: 02754/398-0 – Fax 02754/398-101
E-mail: Verkauf@webermt.de
Internet: http\ www.webermt.de



BITTE, NOTIEREN SIE SERIENNUMMER UND MOTORNUMMER IHRER MASCHINE:

PLEASE WRITE DOWN SERIALNUMBERS OF MACHINE AND ENGINE:

NOTEZ SVP LE NUMERO DE SERIE ET LE NUMERO DU MOTEUR DE VOTRE MACHINE:

SI PREGA DI ANNOTARE SEMPRE I NUMERI DI SERIE SIA DELLA VS. MACCHINA CHE DEL MOTORE:

MAQUINA: ROGAMOS ANOTEN EL NUMERO DE SERIE Y NUMERO DE MOTOR DE SU MAQUINA:

MASCHINE
MACHINE
MACCHINA
MAQUINA

#

MOTOR
ENGINE
MOTEUR
MOTORE

#

ZUR VERMEIDUNG VON FEHLLIEFERUNGEN UND VERZÖGERUNGEN SIND BEI DER BESTELLUNG VON ERSATZTEILEN FOLGENDE ANGABEN UNBEDINGT ERFORDERLICH:

- MASCHINENTYP
- SERIENNUMMER DER MASCHINE
- SERIENNUMMER DES MOTORS (BEI MOTORTEILEN)
- TEILENUMMER
- BESTELLMENGE

TO AVOID ERRORS IN DELIVERY PLEASE STATE THESE PARTICULARS WHEN ORDERING:

- TYPE OF MACHINE
- SERIAL NO. OF MACHINE
- SERIAL NO. OF ENGINE (ON ENGINE PARTS)
- PART-NO.
- QUANTITY REQUIRED

AFIN D'EVITER DES ERREURS DE COMMANDE ET DES RETARDS DE LIVRAISON IL EST NECESSAIRE D'INDIQUER LES CARACTERISTIQUES SUIVANTES:

- TYPE DE MACHINE
- LE NUMERO DE SERIE DE LA MACHINE
- LE NUMERO DE SERIE DU MOTEUR
- LE NUMERO D'IDENTITE DE LA PIECE
- LA QUANTITE SOUHAITEE

ONDE EVITARE DISGUIDI E RITARDI NELLE CONSEGNE DIE RICAMBI SI PREGA DI INDICARE SEMPRE:

- TIPO DELLA MACCHINA
- NUMERO DI SERIE DELLA MACCHINA
- NUMERO DI SERIE DEL MOTORE (SE SI RICHIEDONO PEZZI DEL MOTORE)
- NUMERO D'ORDINE DIE SINGOLI RICAMBI
- QUANTITA

A FI DE EVITAR ERRORES DE ENTREGA, ROGAMOS INDIQUEN LOS SIGUIENTES DATOS CUANDO PASE PEDIDOS DE RECAMBIO:

- MODELO DE MAQUINA
- NO. DE SERIE DE LA MAQUINA
- NO. DE SERIE DEL MOTOR (EN PIEZAS PARAMOTOR)
- REFERENCIA DEL RECAMBIO
- CANTIDAD PEDIDA

E 3154-0604

Posit ion Ref.No. Repère Posizione Posicion	M eng e Quantity Quantité Quantita Cantidad	Teile-Nr. Part-No. No. Référence Nr. d'Ordine No. Referenzia	Hinweis Hint s Indicat ions Indicazio nes	Po sit ion Ref. No. Repère Posizione Posicion	M eng e Quantity Quantité Quantita Cantidad	Teile-Nr. Part-No. No. Référence Nr. d'Ordine No. Referenzia	Hinweis Hint s Indications Indicazio ne Indicaciones
1	1	10001478					
2	1	10017003					
3	2	25025247	DIN608-M12x90				
4	2	25025248	DIN608-M12x145				
5	12	20029032	SKM 12				
6	4	25031015	DIN985-M12				

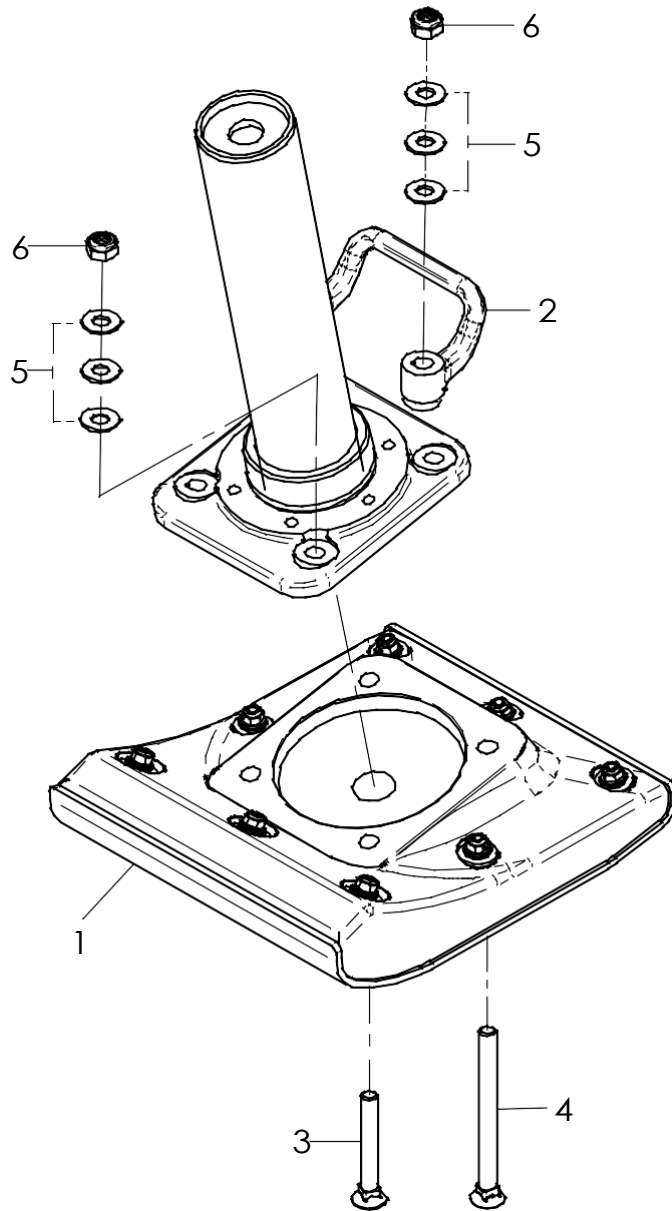

E3154-0604

E 3160-0604

Posit ion Ref.No. Repère Posizione Posicion	M eng e Quantity Quantité Quantita Cantidad	Teile-Nr. Part-No. No. Référence Nr. d'Ordine No. Referenzia	Hinweis Hint s Indicat ions Indicazione Indicacio nes	Po sit ion Ref. No. Repère Posizione Posicion	M eng e Quantity Quantité Quantita Cantidad	Teile-Nr. Part-No. No. Référence Nr. d'Ordine No. Referenzia	Hinweis Hint s Ind ications Indicazione Indicaciones
1	1	10016225					
2	4	25038016	DIN933-M10x35				
3	4	20029001	VSK 10				
4	1	10006970					
5	1	25025157					
6	1	10006969					
7	1	10006972					
8	2	10006971					
9	1	20025520					
9	1	21000073	Z				
10	2	20007039					
11	1	10006973					
12	1	25030014	DIN910-G1/2"				
13	1	20013080					
14	1	20013068					
15	1	10022193					
16	1	20013067					
17	1	10006964					
18	6	25038011	DIN933-M8x40				
19	6	20029003	VSK 8				
20	1	10022668					
21	1	10006965					
22	2	20008053					
23	2	20008035					

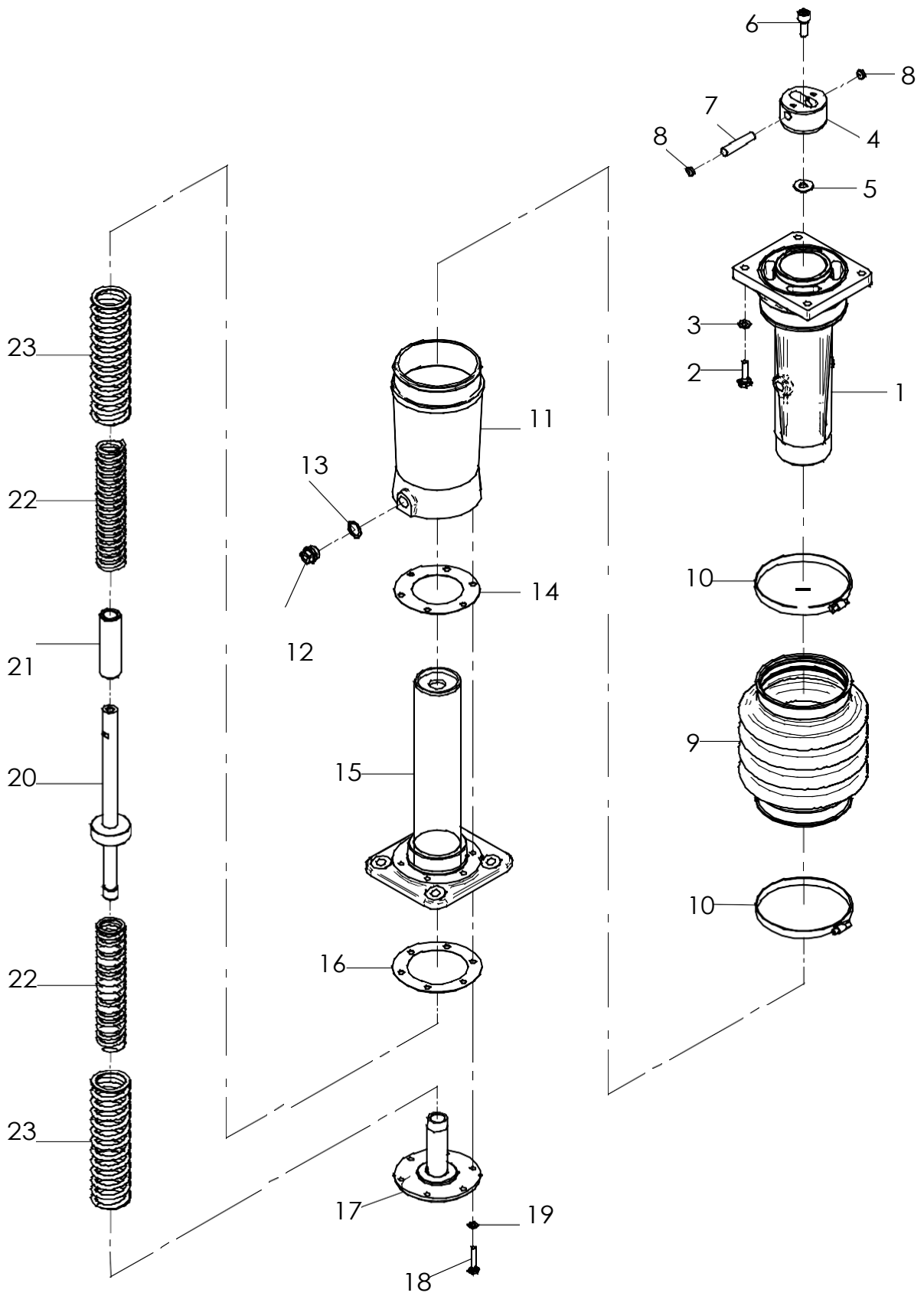

E 3161-0906

Posit ion Ref.No. Repère Posizione Posicion	M eng e Quantity Quantité Quantita Cantidad	Teile-Nr. Part-No. No. Référence Nr. d'Ordine No. Referenzia	Hinweis Hint s Indicat ions Indicazio ne Indicacion es	Po sit ion Ref. No. Repère Posizione Posicion	M eng e Quantity Quantité Quantita Cantidad	Teile-Nr. Part-No. No. Référence Nr. d'Ordine No. Referenzia	Hinweis Hint s Indications Indicazio ne Indicacion es
1	1	10015664		30	2	20029003	VSK 8
2	1	20025523		31	2	20005021	
3	4	20025521		32	2	20022002	Tensilock M8
4	1	20025524		33	1	10015666	
5	4	20025522		34	1	25017033	
6	2	20025522		35	1	25035003	DIN472-I62x2
7	1	10017329		36	1	25001045	
8	1	25035010	DIN472-I72x2,5	37	1	25034006	DIN471-A35x1,5
9	1	25001012		38	2	25049016	DIN440-R9
10	1	25034006	DIN471-A35x1,5	39	4	20029021	SKB 8
11	1	25001047					
12	1	25034016	DIN471-A25x1,2				
13	1	10015665					
13	1	11000237	Z				
14	4	25044063	DIN912-M8x35				
15	4	20029011	VSKZ 8				
16	1	10007093					
17	1	25001257					
18	1	25035025	DIN472-I24x1,2				
19	1	10009653					
20	1	25025167					
21	1	25001206					
22	1	25034003	DIN471-A20x1,2				
23	1	25035008	DIN472-I42x1,75				
24	1	10017310					
25	1	10017311					
26	4	25038011	DIN933-M8x40				
27	4	25048002	DIN125-A8,4				
28	4	25031013	DIN985-M8				
29	2	25038008	DIN933-M8x25				

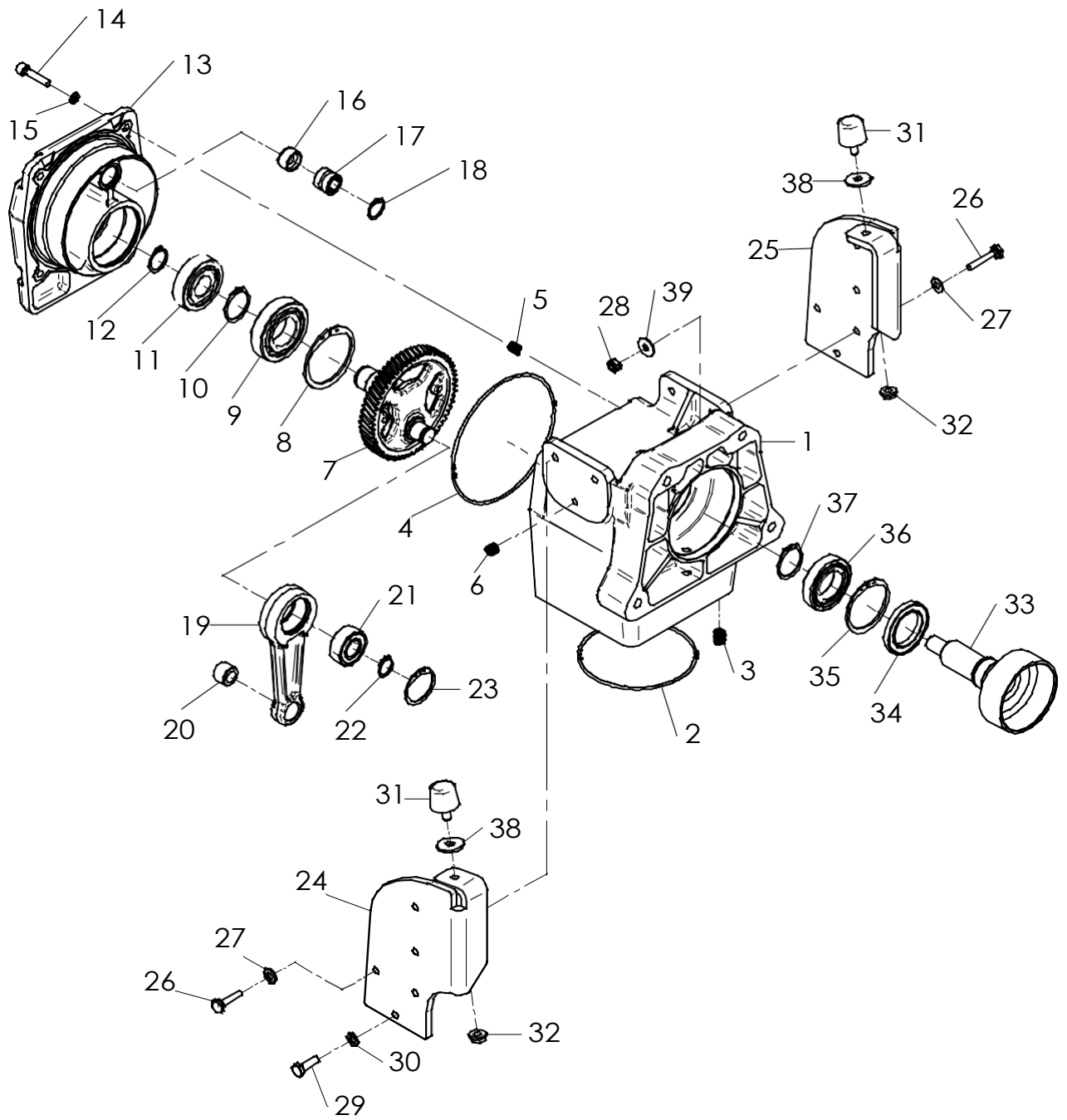

E3161-0906

E 3162-0906

Posit ion Ref.No. Repère Posizione Posicion	M eng e Quantity Quantité Quantita Cantidad	Teile-Nr. Part-No. No. Référence Nr. d'Ordine No. Referenzia	Hinweis Hint s Indicat ions Indicazione Indicacio nes	Po sit ion Ref. No. Repère Posizione Posicion	M eng e Quantity Quantité Quantita Cantidad	Teile-Nr. Part-No. No. Référence Nr. d'Ordine No. Referenzia	Hinweis Hint s Ind ications Indicazione Indicaciones
1	1	21000155					
2	4	25040045	DIN931-M10x70				
3	4	20029001	VSK 10				
4	1	20002074					
5	1	25049016	DIN440-R9				
6	1	20022018	Tensilock M8x20				
7	1	10015745					
8	2	25040027	DIN931-M8x35				
9	2	20022002	Tensilock M8				
10	1	25038058	DIN933-M8x20				
11	1	20029003	VSK 8				
12	1	25049016	DIN440-R9				
13	1	20007018					
14	1	25033039	DIN7981-C5,5x13				

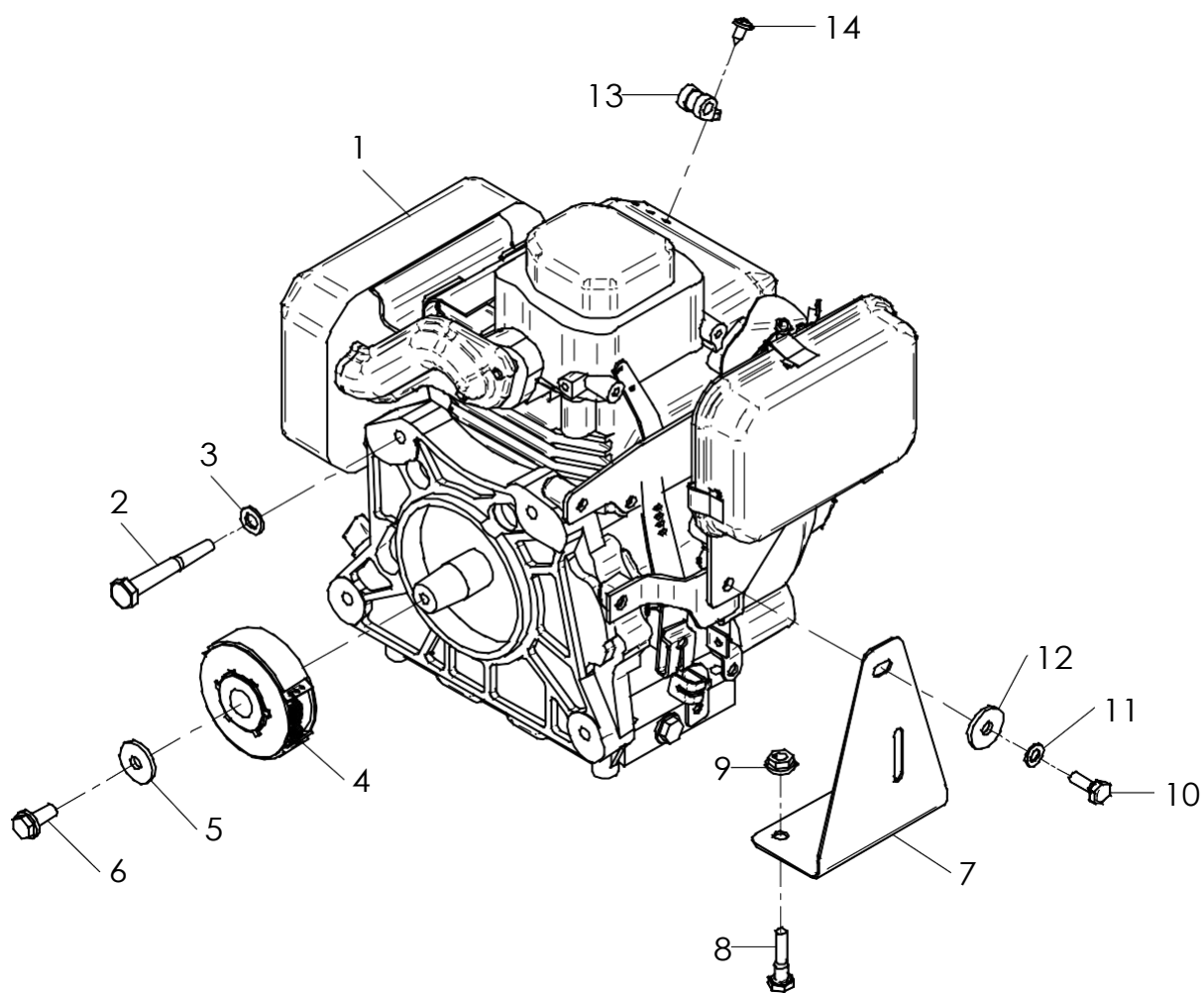

E 3162-0906

E 3163-0604

Position Ref.No. Repère Posizione Posicion	Men ge Quantity Quantité Quantita Cantidad	Teile-Nr. Part-No. No. Référence Nr. d'Ordine No. Referenzia	Hinweis Hint s Indicat ions Indicazione Indicacio nes	Posit ion Ref. No. Repère Posizione Posicion	Men ge Quantity Quantité Quantita Cantidad	Teile-Nr. Part-No. No. Référence Nr. d'Ordine No. Referenzia	Hinweis Hint s Indications Indicazione Indicaciones
1	1	20002074					
2	2	20002254					
3	4	20002255					

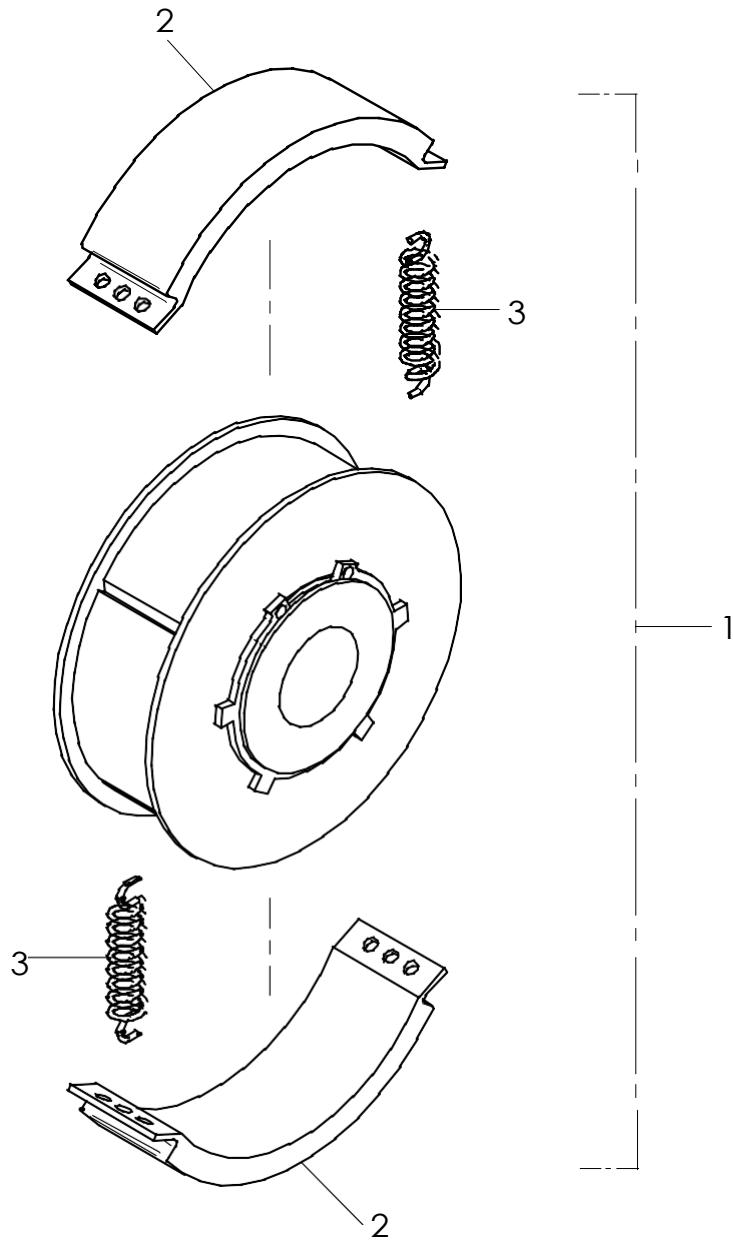

E 3164-0805

Posit ion Ref.No. Repère Posizione Posicion	M enge Quantity Quantité Quantita Cantidad	Teile-Nr. Part -No. No. Référence Nr. d'Ordine No. Referenzia	Hinweis Hint s Ind ications Ind icazione Ind icaciones	Posit ion Ref. No. Repère Posizio ne Posicion	M enge Quant ity Quant ité Quant ita Cantidad	Teile-Nr. Part-No. No. Référence Nr. d'Ordine No. Referenzia	Hinweis Hint s Indicat ions Indicazione Indicacio nes
1	1	10022653		33	2	25031002	DIN934-M6
2	2	20004016		34	1	20008066	
3	7	25038007	DIN933-M8x20	35	1	25038003	DIN933-M6x20
4	7	20029003	VSK 8	36	1	25048001	DIN125-A6,4
5	1	25038008	DIN933-M8x25	37	2	20007007	
6	1	20029003	VSK 8	38	1	25048001	DIN125-A6,4
7	1	25048002	DIN125-A8,4	39	1	25033038	DIN1587-M6
8	1	20007004		40	1	25038002	DIN933-M6x16
9	2	10017327		41	1	25048001	DIN125-A6,4
10	4	25044065	DIN912-M6x25	42	1	20007007	
11	4	25031002	DIN934-M6	43	1	25048001	DIN125-A6,4
12	1	10017361		44	1	25033038	DIN1587-M6
12	1	11000344	Z	45	1	10001483	
13	2	25049026	DIN7349-8,4	46	1	40001767	
14	2	25031013	DIN985-M8	47	2	25033009	DIN85-M4x12
15	1	20026587		48	2	25048023	DIN125-B4,3
16	1	20019423		49	2	25033040	DIN1587-M4
17	4	20026434		50	1	10001484	
18	1	21000012		50	1	11000343	Z
19	1	20026588					
20	1	20013072					
21	0	25025188	DIN988-PS-14x20x0,3				
22	1	20025612					
23	1	11000317					
24	2	20007056					
28	1	20025791					
29	2	25047001	DIN7991-M5x12				
30	2	20029006	VSK 5				
31	2	25033037	DIN1587-M5				
32	1	20006422					

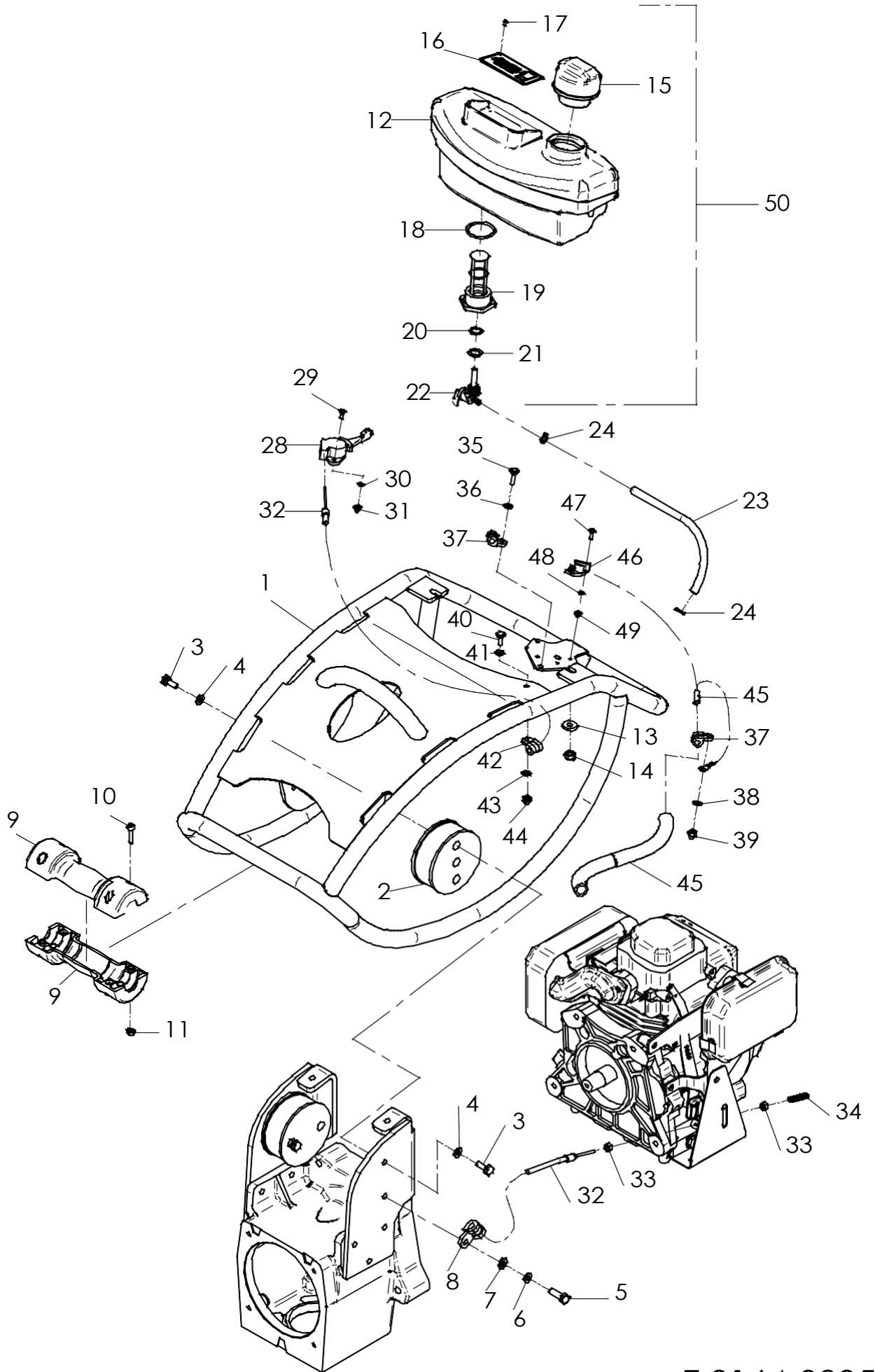

E 3164-0805

**Wenn Sie Fragen und Anregungen haben, oder sonstige Informationen benötigen,
wenden Sie sich bitte an eine der unten genannten Adressen:**

**For questions and further information refer to one of the
following addresses:**

<p>In Deutschland</p> <p>In Germany</p>	<p>WEBER Maschinenteknik GmbH Postfach 2153 57329 Bad Laasphe – Rückershausen</p> <p>Information / information: E-mail: info@webermt.de</p> <p>Ersatzteile / spare parts: E-mail: parts@webermt.de</p>	<p>Telefon / phone:</p> <p>Telefax / fax:</p> <p>Telefax / fax:</p>	<p>+49 (0) 2754/ 3980 Zentrale / switchboard</p> <p>+49 (0) 2754 / 398101 Zentrale / switchboard</p> <p>+49 (0) 2754 / 398102 Ersatzteile / spare parts direct dial</p>
<p>In Holland</p> <p>In Netherlands</p>	<p>WEBER Maschinenteknik B.V. Graafschap Hornelaan 159 6001 AC Weert</p> <p>E-mail: info@webermt.nl</p>	<p>Telefon / phone:</p> <p>Telefax / fax:</p>	<p>+31 (0) 495 /530215</p> <p>+31 (0) 495 /541839</p>
<p>In Frankreich</p> <p>In France</p>	<p>WEBER Technologie S.A.R.L. 26, rue d'Arsonval 69680 Chassieu</p> <p>E-mail: france@webermt.com</p>	<p>Telefon / phone:</p> <p>Telefax / fax:</p>	<p>+33 (0) 472 /791020</p> <p>+33 (0) 472 /791021</p>
<p>In Polen</p> <p>In Poland</p>	<p>WEBER Maschinenteknik SP.ZO.O. ul. Grodziska 7 05-830 Stara Wies /Nadarzyn</p> <p>E-mail: info@webermt.com.pl</p>	<p>Telefon / phone:</p> <p>Telefax / fax:</p>	<p>+48 (0) 22 /7397080 +48 (0) 22 /7397081</p> <p>+48 (0) 22 /7397082</p>
<p>In USA, Kanada</p> <p>In USA,Canada</p>	<p>WEBER Machine (USA), Inc. 40 Johnson Ave 112 Bangor, ME 04401 USA</p> <p>E-mail: usa@webermt.com</p>	<p>Telefon / phone:</p> <p>Telefax / fax:</p>	<p>+1 (0) 207 /9474990</p> <p>+1 (0) 207 /9475452</p>
<p>In Südamerika</p> <p>In South America</p>	<p>WEBER Maschinenteknik do Brasil Ltda. Rua Sete de Setembro, 275 93332-470 Novo Hamburgo, RS Brasil</p> <p>E-mail: webermt@webermt.com.br</p>	<p>Telefon / phone:</p> <p>Telefax / fax:</p>	<p>+55 (0) 51 /5873044</p> <p>+55 (0) 51 /5872271</p>

<http://www.webermt.com>

